

SİLİKON CEPHE
SILICONE FACADE

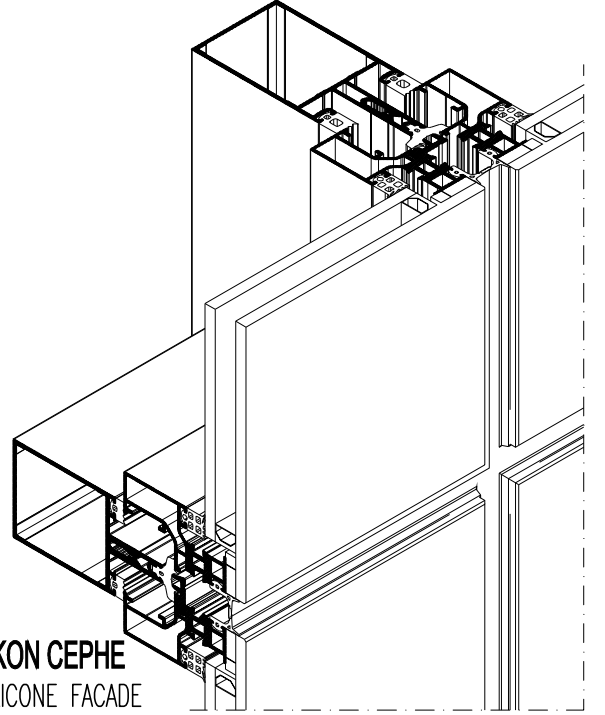

ISI YALITIMLI SİLİKON CEPHE
HEAT INSULATING SILICONE FACADE

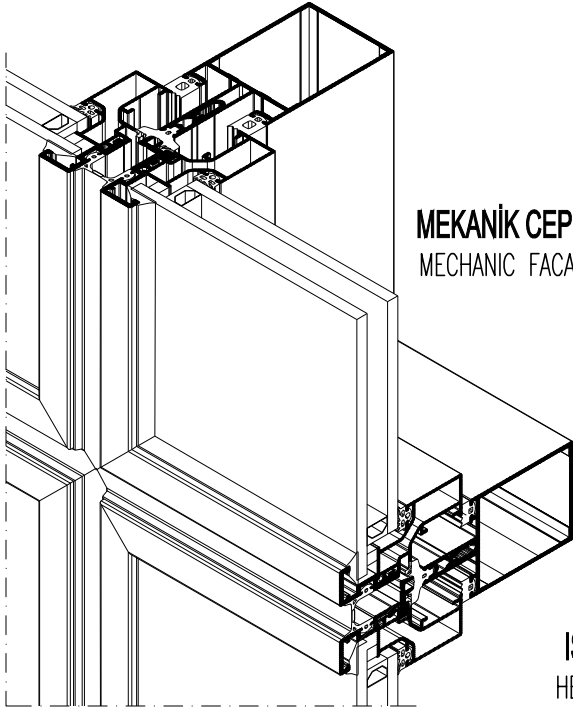

MEKANİK CEPHE
MECHANIC FACADE

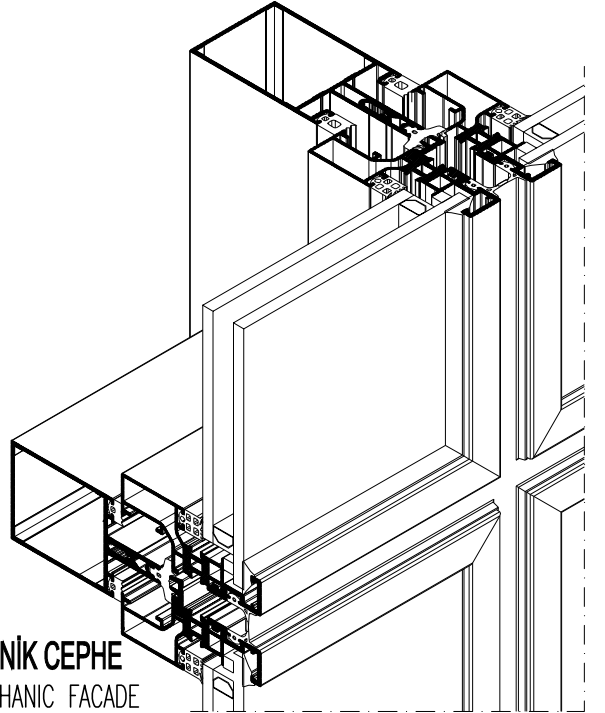





ISI YALITIMLI MEKANİK CEPHE
HEAT INSULATING MECHANIC FACADE

F50 KONDENS SİSTEM
SİLİKON CEPHE

F50 CONDENSAT SYSTEM
SILICONE FACADE

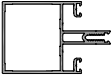
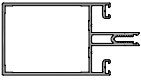
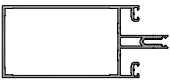
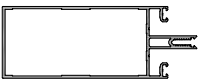
**F50 KONDENS SİSTEM
SİLİKON CEPHE**
F50 CONDENSAT SYSTEM
SILICONE FACADE

ÜRÜN TEKNİK ÖZELLİKLERİ
PRODUCT'S TECHNICAL FEATURES

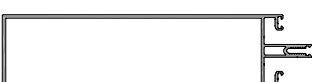
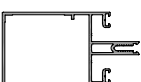
No. Nr.	PROFİL KESİTİ PROFILE VIEW	PROFİL NO PROFILE NO	PROFİL AÇIKLAMASI PROFILE DESCRIPTION	BAĞLANTI PARÇALARI CORNER CLEATS	gr/m	STATİK STATIC			
						Ix cm ⁴	Iy cm ⁴	Wx cm ³	Wy cm ³
1	 <small>İşaretili profil için satış ekibinden bilgi alınır.</small>	F0101 (35 - 50) (1.7 mm)	TAŞIYICI PROFİL MULLION PROFILE	SC0316-20 (17.5 mm)	1287	10.93	11.95	3.41	4.78
2		F0102 (55 - 50) (1.7 mm)	TAŞIYICI PROFİL MULLION PROFILE	SC0316-21 (37.5 mm)	14.71	26.56	15.92	6.76	6.37
3		F0103 (75 - 50) (1.7 mm)	TAŞIYICI PROFİL MULLION PROFILE	SC0316-22 (57.5 mm)	1655	52.42	19.88	10.96	7.95
4		F0104 (95 - 50) (1.7 mm)	TAŞIYICI PROFİL MULLION PROFILE	SC0316-23 (77.5 mm)	1839	90.05	23.85	15.13	9.54
5		F0105 (115 - 50) (1.7 mm)	TAŞIYICI PROFİL MULLION PROFILE	SC0316-24 (97.5 mm)	2085	146.54	28.57	21.05	11.43
6		F0106 (135 - 50) (1.7 mm)	TAŞIYICI PROFİL MULLION PROFILE	SC0316-25 (117.3 mm)	2300	219.98	32.71	27.51	13.08
7		F0107 (155 - 50) (1.8 mm)	TAŞIYICI PROFİL MULLION PROFILE	SC0316-26 (137.3 mm)	2598	316.68	38.56	35.11	15.42
8		F0108 (175 - 50) (2.1 mm)	TAŞIYICI PROFİL MULLION PROFILE	SC0316-27 (157.1 mm)	3008	447.36	46.78	45.10	18.71
9		F0109 (195 - 50) (2.3 mm)	TAŞIYICI PROFİL MULLION PROFILE	SC0316-28 (177.1 mm)	3452	613.16	55.61	56.50	22.24
10	 <small>İşaretili profil için satış ekibinden bilgi alınır.</small>	F0122 (75 - 75) (1.7 mm)	90° KÖŞE TAŞIYICI PROFİL MULLION PROFILE	SC0316-22 (57.5 mm)	2375	69.55	68.64	12.81	12.65

Profil değerleri teoriktir. Ağırlık olarak testimde yapılan tartım geçerlidir.
Profil imatları TS EN 12020-2 ve TS EN 755-9 toleransı,
Moment değerleri EN 14024'e göre hesaplanmıştır.

Profile values are theoretical pre-shipment weight will be valid.
The tolerances of Profile manufacturing are calculated according to EN 12020-2
and TS EN 755-9; moment values are calculated according to EN 14024.

**F50 KONDENS SİSTEM
SİLİKON CEPHE**
F50 CONDENSAT SYSTEM
SILICONE FACADE

ÜRÜN TEKNİK ÖZELLİKLERİ
PRODUCT'S TECHNICAL FEATURES











No. Nr.	PROFİL KESİTİ PROFILE VIEW	PROFİL NO PROFILE NO	PROFİL AÇIKLAMASI PROFILE DESCRIPTION	BAĞLANTI PARÇALARI CORNER CLEATS	gr/m	STATİK STATIC			
						Ix cm ⁴	Iy cm ⁴	Wx cm ³	Wy cm ³
11		F0123 (95 - 95) (1.7 mm)	90° KÖŞE TAŞIYICI PROFİL MULLION PROFILE	SC0316-23 (77.5 mm)	2689	129.57	127.68	19.44	19.10
12		F0131 (5,5 - 50) (2 mm)	TAŞIYICI PROFİL TRANSOM PROFILE		584	0.56	3.32	0.38	1.33
13		F0132 (20 - 50) (1.7 mm)	TAŞIYICI PROFİL TRANSOM PROFILE	F0310-1 (12 mm) F0311-1 (12 mm)	949	2.91	7.95	1.40	3.18
14		F0133 (40 - 50) (1.7 mm)	TAŞIYICI PROFİL TRANSOM PROFILE	F0310-2 (32 mm) F0501-2 (32 mm)	1140	11.79	12.05	4.12	4.82
15		F0134 (60 - 50) (1.7 mm)	TAŞIYICI PROFİL TRANSOM PROFILE	F0310-3 (52 mm) F0311-3 (52 mm)	1324	28.79	16.02	7.78	6.41
16		F0135 (80 - 50) (1.7 mm)	TAŞIYICI PROFİL TRANSOM PROFILE	F0310-4 (59.4 mm) F0311-4 (59.4 mm)	1532	56.17	20.41	11.77	8.16
17		F0136 (100 - 50) (1.7 mm)	TAŞIYICI PROFİL TRANSOM PROFILE	F0310-5 (79.4 mm) F0311-5 (79.4 mm)	1716	94.45	24.38	16.13	9.75
18		F0137 (120 - 50) (1.7 mm)	TAŞIYICI PROFİL TRANSOM PROFILE	F0310-6 (99.4 mm) F0311-6 (99.4 mm)	1900	145.28	28.34	20.99	11.34
19		F0138 (140 - 50) (2 mm)	TAŞIYICI PROFİL TRANSOM PROFILE	F0310-7 (119.4 mm) F0311-7 (119.4 mm)	2305	225.73	36.21	28.95	14.49
20		F0139 (160 - 50) (2.1 mm)	TAŞIYICI PROFİL TRANSOM PROFILE	F0310-8 (139.4 mm) F0311-8 (139.4 mm)	2617	322.46	42.51	36.81	17.00

Profil değerleri teoriktir. Ağırlık olarak testimde yapılan tartım geçerlidir.
Profil imalatları TS EN 12020-2 ve TS EN 755-9 toleransları,
Moment değerleri EN 14024'e göre hesaplanmıştır.

Profile values are theoretical pre-shipment weight will be valid.
The tolerances of Profile manufacturing are calculated according to EN 12020-2
and TS EN 755-9; moment values are calculated according to EN 14024.

**F50 KONDENS SİSTEM
SİLİKON CEPHE**
F50 CONDENSAT SYSTEM
SILICONE FACADE

ÜRÜN TEKNİK ÖZELLİKLERİ
PRODUCT'S TECHNICAL FEATURES

No. Nr.	PROFİL KESİTİ PROFILE VIEW	PROFİL NO PROFILE NO	PROFİL AÇIKLAMASI PROFILE DESCRIPTION	BAĞLANTI PARÇALARI CORNER CLEATS	gr/m	STATİK STATIC			
						Ix cm ⁴	Iy cm ⁴	Wx cm ³	Wy cm ³
21		F0140 (180 - 50) (21 mm)	TAŞIYICI PROFİL TRANSOM PROFILE	F0310-9 (159,4 mm) F0311-9 (159,4 mm)	2845	431.76	47.33	14.12	18.93
22		F0141 (200 - 50) (21 mm)	TAŞIYICI PROFİL TRANSOM PROFILE	F0310-10 (178 mm) F0311-10 (178 mm)	3246	624.38	53.27	57.86	21.31
23		F0142 (50 - 50) (16 mm)	TAŞIYICI PROFİL TRANSOM PROFILE	F0310-11 (42 mm) F0311-11 (42 mm)	1178	18.59	13.43	5.69	5.37
24		F0143 (160 - 50) (16 mm)	TAŞIYICI PROFİL TRANSOM PROFILE	F0310-8 (159,4 mm) F0311-8 (159,4 mm)	2243	18.59	13.43	5.69	5.37
25		F0136-G (100 - 50) (17 mm)	TAŞIYICI PROFİL TRANSOM PROFILE	F0310-5 (79,4 mm) F0311-5 (79,4 mm)	1485				
26		F0310 (27,2 - 45,7) (22 mm)	KLASİK U BAĞLANTI PR. T-CONNECTOR FOR TRANSOM PROFILE		841				
27		F0311 (36,4 - 45) (55 mm)	AÇILI U BAĞLANTI PR. T-CONNECTOR FOR TRANSOM PROFILE		947				
28		F0312 (37,1 - 45,6) (22 mm)	KIRLANGIÇ GEÇME PROFİLİ T-CONNECTOR FOR TRANSOM PROFILE		1500				
29		F0313 (8,5 - 45,6) (3 mm)	KIRLANGIÇ GEÇME PROFİLİ T-CONNECTOR FOR TRANSOM PROFILE		446				
30		F0314 (36,7 - 45,6) (19 mm)	KLASİK U BAĞLANTI PR. T-CONNECTOR FOR TRANSOM PROFILE		1535				

Profil değerleri teoriktir. Ağırlık olarak testimde yapılan tartım geçerlidir.
Profil imalatları TS EN 12020-2 ve TS EN 755-9 toleransları,
Moment değerleri EN 14024'e göre hesaplanmıştır.

Profile values are theoretical pre-shipment weight will be valid.
The tolerances of Profile manufacturing are calculated according to EN 12020-2
and TS EN 755-9; moment values are calculated according to EN 14024.

**F50 KONDENS SİSTEM
SİLİKON CEPHE**
F50 CONDENSAT SYSTEM
SILICONE FACADE

ÜRÜN TEKNİK ÖZELLİKLERİ
PRODUCT'S TECHNICAL FEATURES







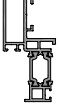
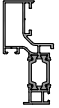

No. Nr.	PROFİL KESİTİ PROFILE VIEW	PROFİL NO PROFILE NO	PROFİL AÇIKLAMASI PROFILE DESCRIPTION	BAĞLANTI PARÇALARI CORNER CLEATS	gr/m	STATİK STATIC			
						Ix cm ⁴	Iy cm ⁴	Wx cm ³	Wy cm ³
31		SC0201 (34,9 - 49,5) (13 mm)	ÇİFT CAM PANEL PROFİLİ PANEL PROFILE FOR DOUBLE GLASS	SC0308-a (25,68 mm) SC0307-a (10,25 mm) SC0304-a (50 mm)	734				
32		SC0202 (34,9 - 49,5) (13 mm)	TEK CAM PANEL PROFİLİ PANEL PROFILE FOR SINGLE GLASS	SC0308-a (25,68 mm) SC0307-a (10,25 mm) SC0304-a (50 mm)	636				
33		SC0203 (34,9 - 57) (13 mm)	KOMPOZİT PANEL PROFİLİ PANEL PROFILE FOR COMPOSITE	SC0308-a (25,68 mm) SC0307-a (10,25 mm) SC0304-a (50 mm)	643				
34		SC0204 (34,9 - 59,6) (13 mm)	ÇİFT CAM PANEL PROFİLİ PANEL PROFILE FOR DOUBLE GLASS	SC0308-b (29,74 mm) SC0309-a (6,5 mm) SC0304-a (50 mm)	PVC 970				
					POLYAMİD 963				
35		SC0205 (34,9 - 59,6) (13 mm)	TEK CAM PANEL PROFİLİ PANEL PROFILE FOR SINGLE GLASS	SC0308-b (29,74 mm) SC0309-a (6,5 mm) SC0304-a (50 mm)	PVC 894				
					POLYAMİD 886				
36		SC0206 (34,9 - 59,1) (13 mm)	KOMPOZİT PANEL PROFİLİ PANEL PROFILE FOR COMPOSITE	SC0308-b (29,74 mm) SC0309-a (6,5 mm) SC0304-a (50 mm)	PVC 924				
					POLYAMİD 917				
37		SC0207 (19,1 - 4,9) (15 mm)	SİLİKON YAPIŞTIRMA PR. SILICONE BONDING PROFILE		109				
38		SC0209 (22,1 - 49,5) (13 mm)	BİTİM PROFİLİ COMPLETION PROFILE	SC0307-a (10,25 mm) SC0304-a (50 mm)	593				
39		SC0210 (36,1 - 50,5) (2 mm)	ÇİFT CAM PANEL PROFİLİ PANEL PROFILE FOR DOUBLE GLASS	SC0308-a (25,68 mm) SC0307-a (10,25 mm) SC0304-a (50 mm)	1001				
40		SC0214 (36,1 - 61,1) (2 mm)	ÇİFT CAM PANEL PROFİLİ PANEL PROFILE FOR DOUBLE GLASS	SC0308-b (29,74 mm) SC0309-a (6,5 mm) SC0304-a (50 mm)	PVC 1275				
					POLYAMİD 1268				

Profil değerleri teoriktir. Ağırlık olarak testimde yapılan tartım geçerlidir.
Profil imalatları TS EN 12020-2 ve TS EN 755-9 toleransları,
Moment değerleri EN 14024'e göre hesaplanmıştır.

Profile values are theoretical pre-shipment weight will be valid.
The tolerances of Profile manufacturing are calculated according to EN 12020-2
and TS EN 755-9; moment values are calculated according to EN 14024.

**F50 KONDENS SİSTEM
SİLİKON CEPHE**
F50 CONDENSAT SYSTEM
SILICONE FACADE

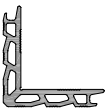
ÜRÜN TEKNİK ÖZELLİKLERİ
PRODUCT'S TECHNICAL FEATURES

No. Nr.	PROFİL KESİTİ PROFILE VIEW	PROFİL NO PROFILE NO	PROFİL AÇIKLAMASI PROFILE DESCRIPTION	BAĞLANTI PARÇALARI CORNER CLEATS	gr/m	STATİK STATIC			
						Ix cm ⁴	Iy cm ⁴	Wx cm ³	Wy cm ³
41		SC0215 (33.2 - 73.1) (2 mm)	ÇİFT CAM PANEL PROFİLİ PANEL PROFILE FOR DOUBLE GLASS	SC0308-b (29,74 mm) SC0309-a (6,5 mm) SC0304-a (50 mm)	PVC 1365 POLYAMID 1350				
42		SC0216 (32 - 71.6) (13 mm)	TEK CAM PANEL PROFİLİ PANEL PROFILE FOR SINGLE GLASS	SC0308-b (29,74 mm) SC0309-a (6,5 mm) SC0304-a (50 mm)	PVC 1060 POLYAMID 1045				
43		SC0217 (13.8 - 27.9) (13 mm)	BITİM PROFİLİ COMPLETION PROFILE	SC0304-a (50 mm)	242				
44		SC0218 (33.5 - 64.5) (13 mm)	ÇİFT CAM PANEL PROFİLİ PANEL PROFILE FOR DOUBLE GLASS	SC0308-b (29,74 mm) SC0308-g (19,5 mm) SC0304-a (50 mm)	1250				
45		SC0219 (33.5 - 64.5) (2 mm)	ÇİFT CAM PANEL PROFİLİ PANEL PROFILE FOR DOUBLE GLASS	SC0308-b (29,74 mm) SC0308-l (5,6 mm) SC0304-a (50 mm)	PVC 1449 POLYAMID 1442				
46		SC0304 (19 - 7.6) (2.8 mm)	DIŞTAN BAĞLANTI PROFİLİ OUTSIDE CONNECTION PROFILE		238				
47		SC0307 (55 - 55) (9.71 mm)	KÖŞE BİRLEŞTİRME PROFİLİ CORNER CLEATS PROFILE		2140				
48		SC0308 (70 - 70) (11.82 mm)	KÖŞE BİRLEŞTİRME PROFİLİ CORNER CLEATS PROFILE		2392				
49		SC0309 (55 - 55) (6.9 mm)	KÖŞE BİRLEŞTİRME PROFİLİ CORNER CLEATS PROFILE		1636				
50		SC0312 (25.1 - 4.2) (2 mm)	CAM OTURTMA PROFİLİ GLAZING SUPPORT FOR SASH PROFILE		147				

Profil değerleri teoriktir. Ağırlık olarak testimde yapılan tartım geçerlidir.
Profil imalatları TS EN 12020-2 ve TS EN 755-9 toleransı,
Moment değerleri EN 14024'e göre hesaplanmıştır.

Profile values are theoretical pre-shipment weight will be valid.
The tolerances of Profile manufacturing are calculated according to EN 12020-2
and TS EN 755-9; moment values are calculated according to EN 14024.

**F50 KONDENS SİSTEM
SİLİKON CEPHE**
F50 CONDENSAT SYSTEM
SILICONE FACADE

ÜRÜN TEKNİK ÖZELLİKLERİ
PRODUCT'S TECHNICAL FEATURES

No. Nr.	PROFİL KESİTİ PROFILE VIEW	PROFİL NO PROFILE NO	PROFİL AÇIKLAMASI PROFILE DESCRIPTION	BAĞLANTI PARÇALARI CORNER CLEATS	gr/m	STATİK STATIC			
						Ix cm ⁴	Iy cm ⁴	Wx cm ³	Wy cm ³
51		SC0316 (14,0 - 45,7) (1,9 mm)	DİLATASYON PROFİLİ DILATATION PROFILE		3079				
52		SC0343 (12,1 - 21,7) (1,8 mm)	İÇTEN BAĞLANTI PROFİLİ INSIDE CONNECTION PROFILE		173				
53		SC0344 (16 - 25,4) (2 mm)	İÇTEN BAĞLANTI PROFİLİ INSIDE CONNECTION PROFILE		244				
54		SC0350 (23,2 - 6,7) (1,2 mm)	CAM OTURTMA PROFİLİ GLAZING SUPPORT FOR SASH PROFILE		140				
55		MC0201 (20 - 35,5) (2 mm)	TIRNAK ADAPTÖR PROFİLİ CLAW ADAPTER PROFILE		397				
56		MC0202 (18 - 31,5) (2 mm)	TIRNAK ADAPTÖR PROFİLİ CLAW ADAPTER PROFILE		378				
57		SC0303 (4,4 - 19,5) (1,5 mm)	TİJ PROFİLİ PUSHING ROD PROFILE		96				
58		F0301 (20,3 - 9) (1,9 mm)	TAŞIYICI EK PROFİL MULLION OR TRANSOM ADDITION PR.		224				
59									
60									

Profil değerleri teoriktir. Ağırlık olarak testimde yapılan tartım geçerlidir.
Profil imalatları TS EN 12020-2 ve TS EN 755-9 toleransı,
Moment değerleri EN 14024'e göre hesaplanmıştır.

Profile values are theoretical pre-shipment weight will be valid.
The tolerances of Profile manufacturing are calculated according to EN 12020-2
and TS EN 755-9; moment values are calculated according to EN 14024.

F50 KONDENS SİSTEM SİLİKON CEPHE PROFİLLERİ

F50 CONDENSAT SYSTEM
SILICONE FACADE PROFILE

ÜRÜN TEKNİK ÖZELLİKLERİ
PRODUCT'S TECHNICAL FEATURES

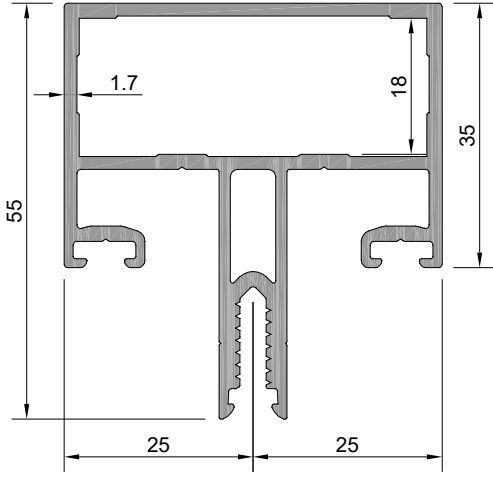

Profil No: F0101 
Ağırlık : 1287 gr/m
Ix : 10,93 cm⁴
Iy : 11,95 cm⁴
wx : 3,41 cm³
wy : 4,78 cm³



SC0316-20

 İşaretti profil için satış ekibinden bilgi alınız.

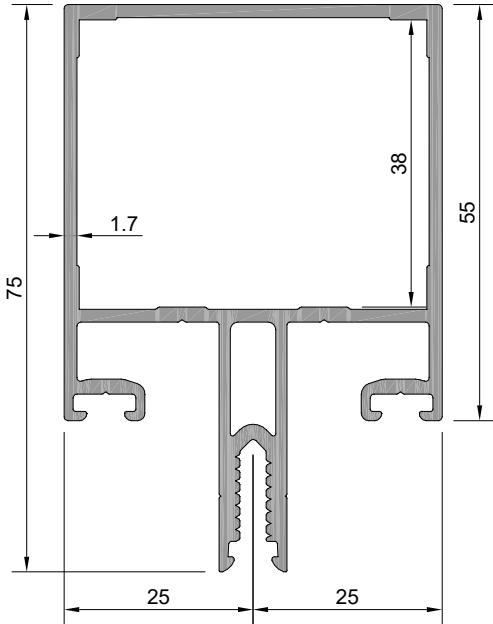

Profil No: F0102
Ağırlık : 1471 gr/m
Ix : 26,56 cm⁴
Iy : 15,92 cm⁴
wx : 6,76 cm³
wy : 6,37 cm³



SC0316-21

F50 KONDENS SİSTEM SİLİKON CEPHE PROFİLLERİ

F50 CONDENSAT SYSTEM
SILICONE FACADE PROFILE

ÜRÜN TEKNİK ÖZELLİKLERİ
PRODUCT'S TECHNICAL FEATURES

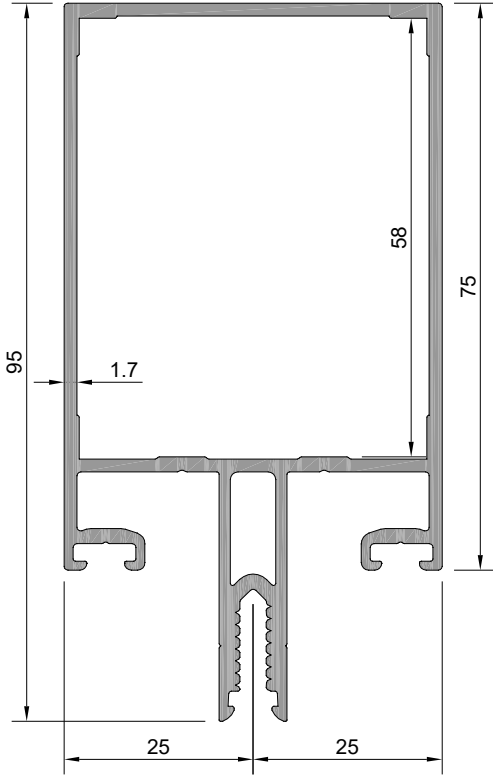

Profil No: F0103

Ağırlık : 1655 gr/m

I_x : 52,42 cm⁴

I_y : 19,88 cm⁴

w_x : 10,96 cm³

w_y : 7,95 cm³



SC0316-22

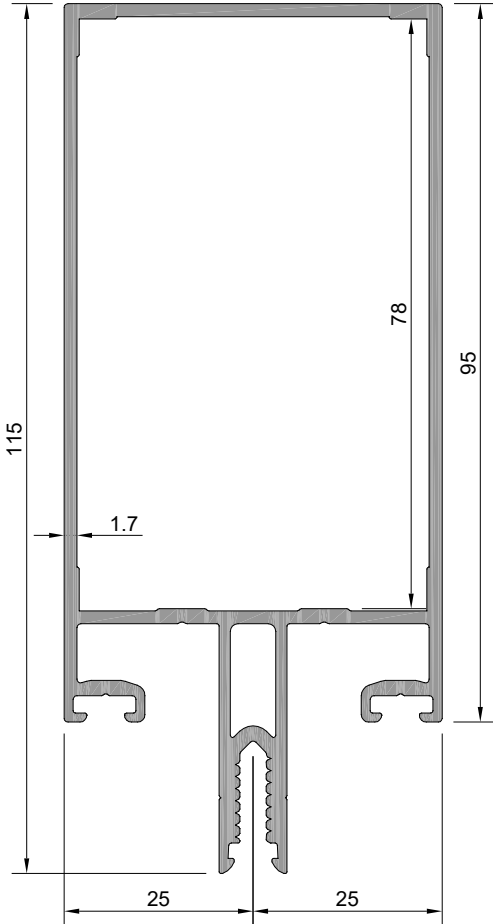

Profil No: F0104

Ağırlık : 1839 gr/m

I_x : 90,05 cm⁴

I_y : 23,85 cm⁴

w_x : 15,13 cm³

w_y : 9,54 cm³



SC0316-23

F50 KONDENS SİSTEM SİLİKON CEPHE PROFİLLERİ

F50 CONDENSAT SYSTEM
SILICONE FACADE PROFILE

ÜRÜN TEKNİK ÖZELLİKLERİ
PRODUCT'S TECHNICAL FEATURES

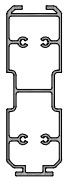
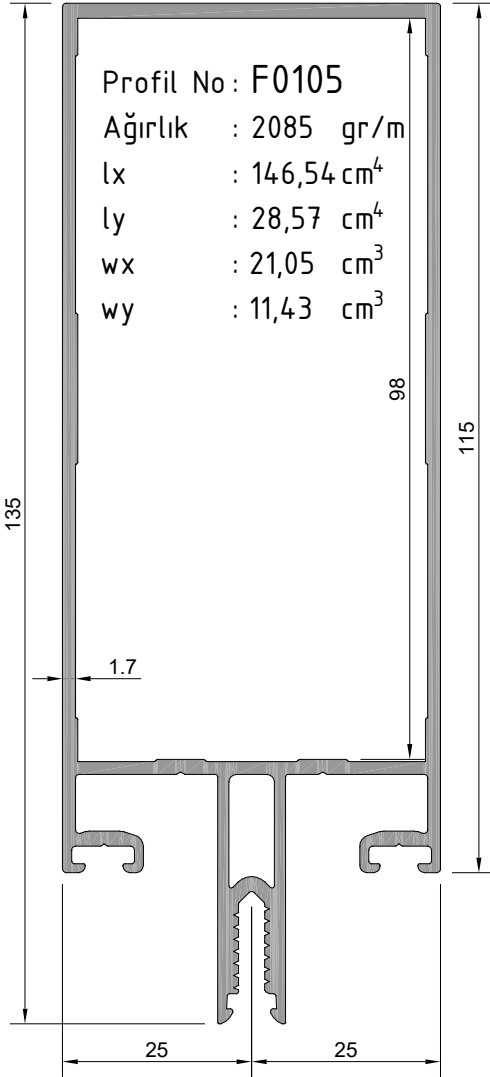

SC0316-24

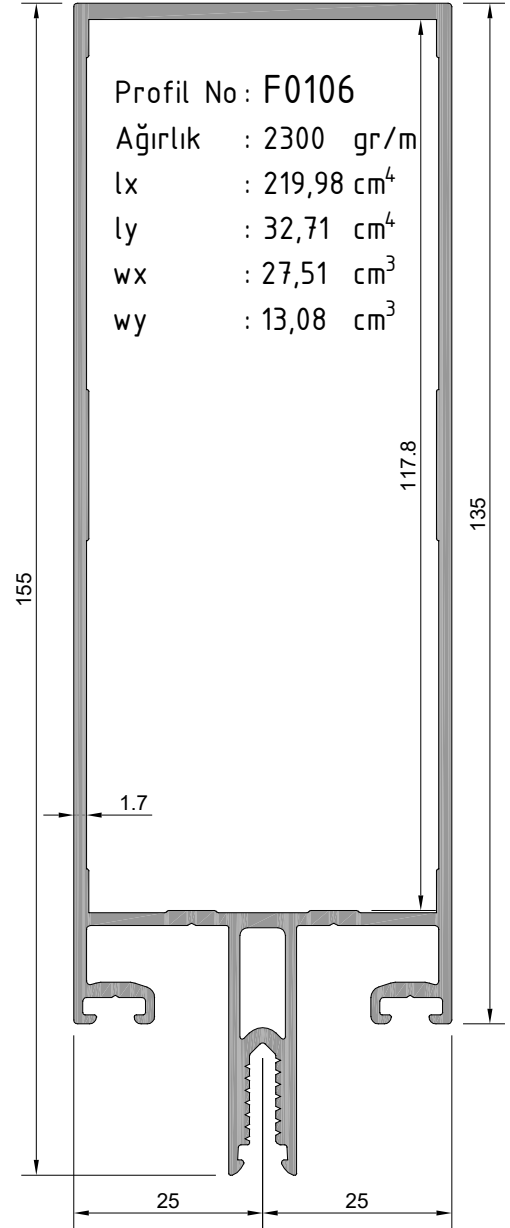

SC0316-25

F50 KONDENS SİSTEM SİLİKON CEPHE PROFİLLERİ

F50 CONDENSAT SYSTEM
SILICONE FACADE PROFILE

ÜRÜN TEKNİK ÖZELLİKLERİ
PRODUCT'S TECHNICAL FEATURES

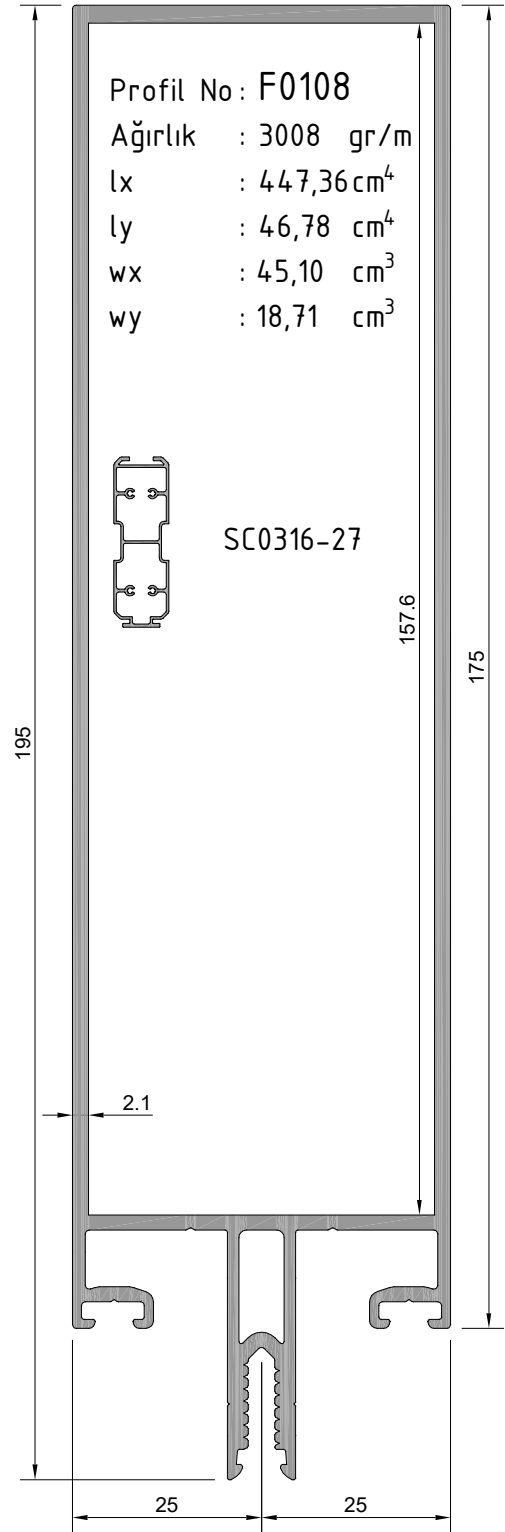
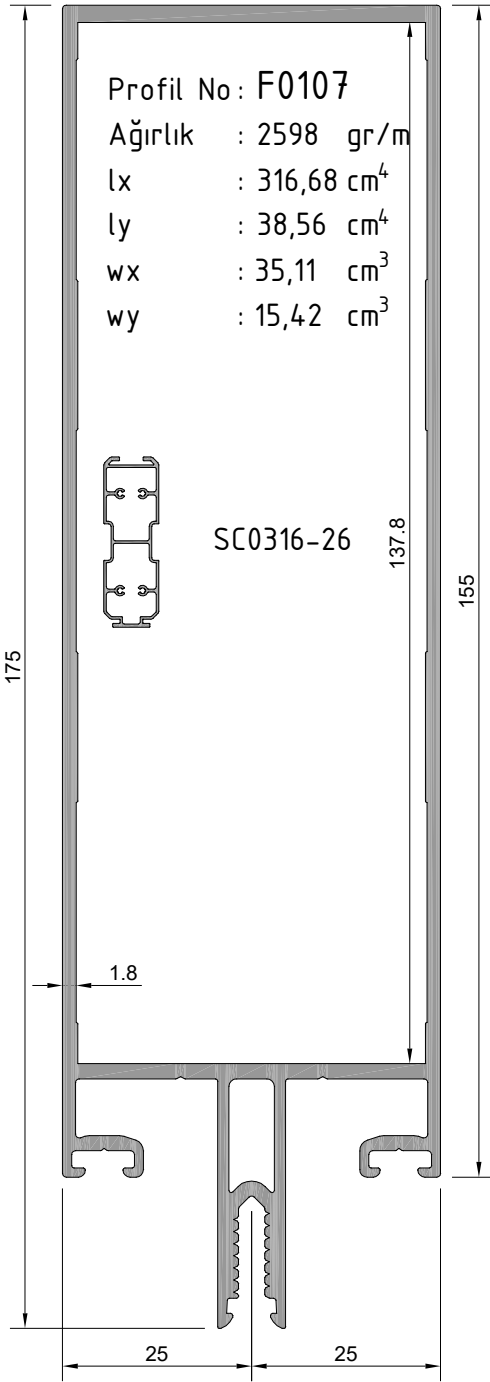

F50 KONDENS SİSTEM SİLİKON CEPHE PROFİLLERİ

F50 CONDENSAT SYSTEM
SILICONE FACADE PROFILE

ÜRÜN TEKNİK ÖZELLİKLERİ
PRODUCT'S TECHNICAL FEATURES

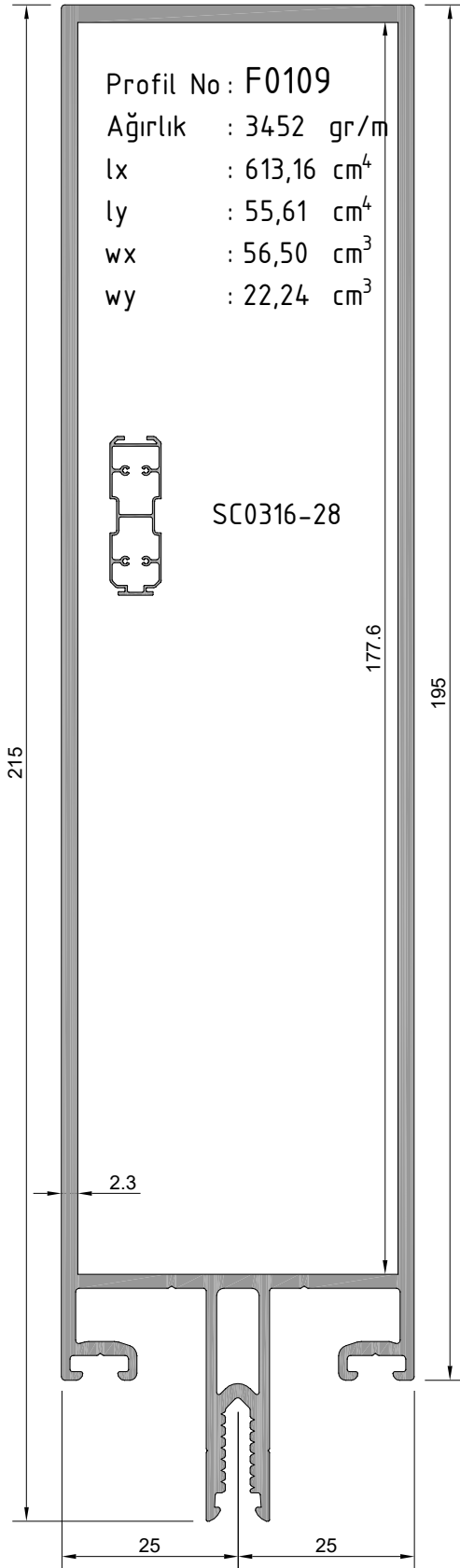

F50 KONDENS SİSTEM SİLİKON CEPHE PROFİLLERİ

F50 CONDENSAT SYSTEM
SILICONE FACADE PROFILE

ÜRÜN TEKNİK ÖZELLİKLERİ
PRODUCT'S TECHNICAL FEATURES

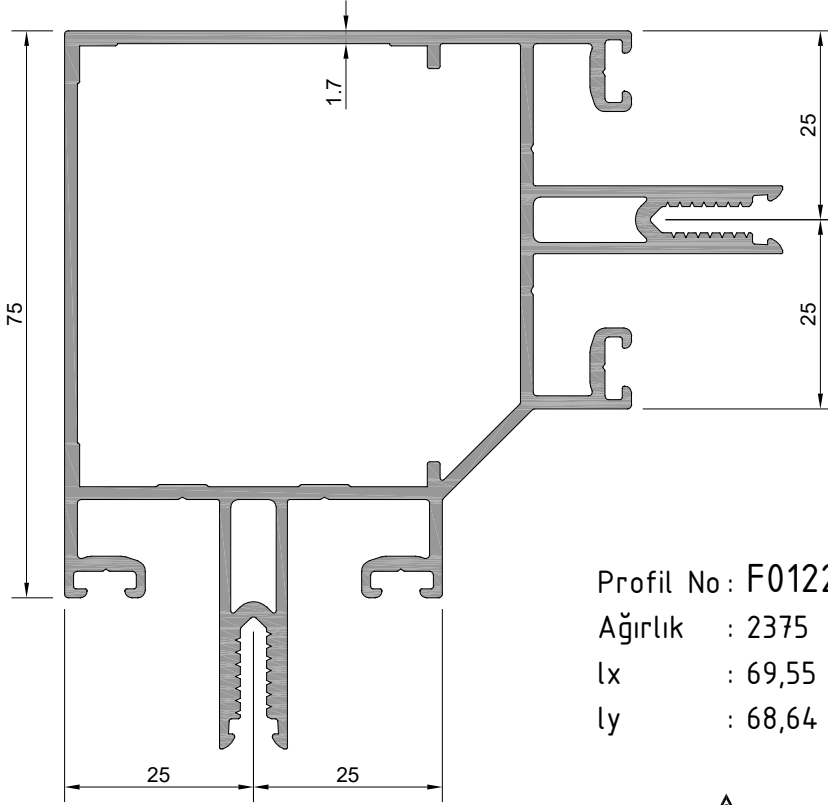

Profil No : F0122 ⚠

Ağırlık : 2375 gr/m

I_x : 69,55 cm^4

I_y : 68,64 cm^4

⚠ İşaretili profil için satış ekibinden bilgi alınız.



SC0316-22

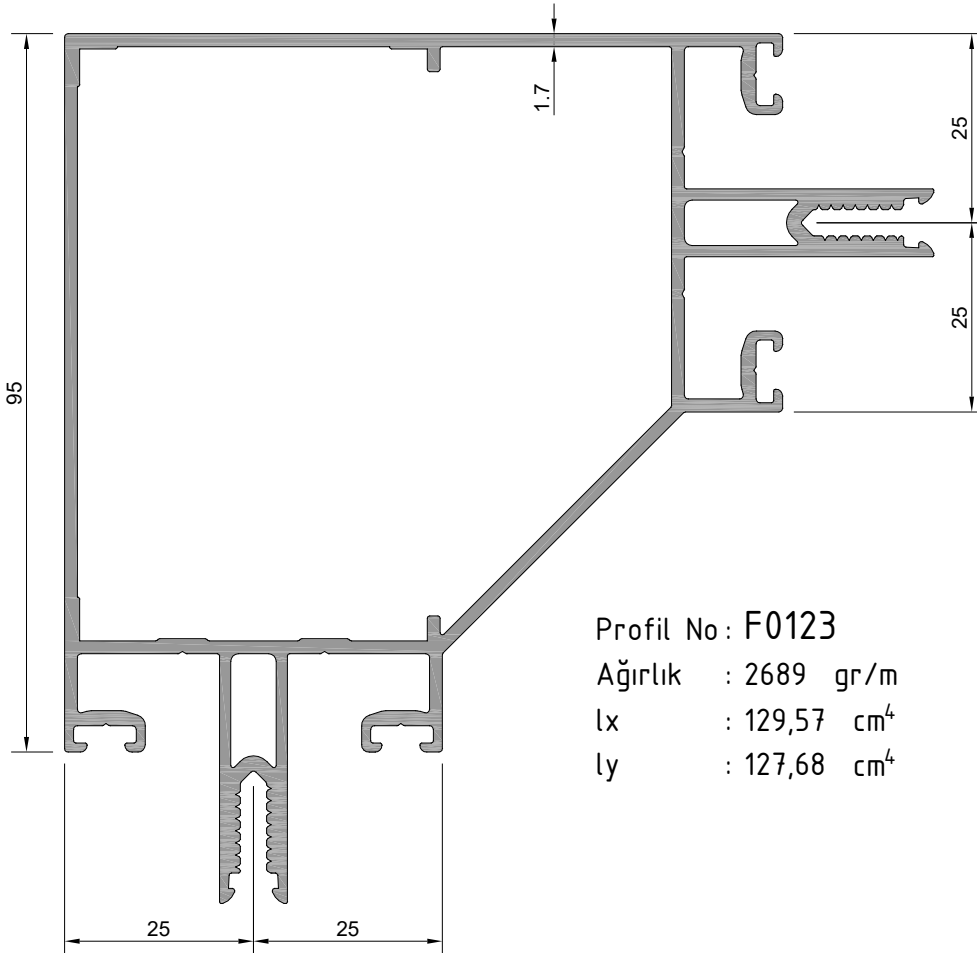

Profil No : F0123

Ağırlık : 2689 gr/m

I_x : 129,57 cm^4

I_y : 127,68 cm^4



SC0316-23

F50 KONDENS SİSTEM SİLİKON CEPHE PROFİLLERİ

F50 CONDENSAT SYSTEM
SILICONE FACADE PROFILE

ÜRÜN TEKNİK ÖZELLİKLERİ
PRODUCT'S TECHNICAL FEATURES

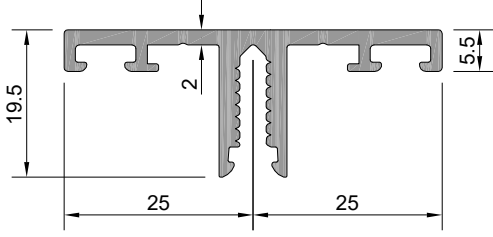

Profil No: F0131

Ağırlık : 584 gr/m

I_x : 0,56 cm^4

I_y : 3,32 cm^4

w_x : 0,38 cm^3

w_y : 1,33 cm^3

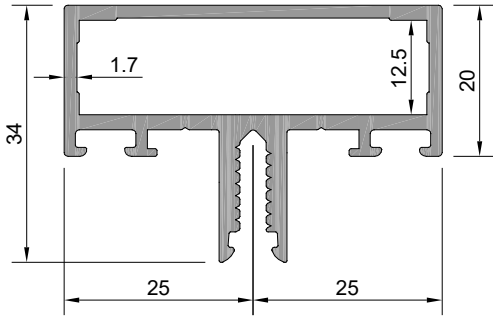

Profil No: F0132

Ağırlık : 949 gr/m

I_x : 2,91 cm^4

I_y : 7,95 cm^4

w_x : 1,40 cm^3

w_y : 3,18 cm^3



F0310-1



F0311-1

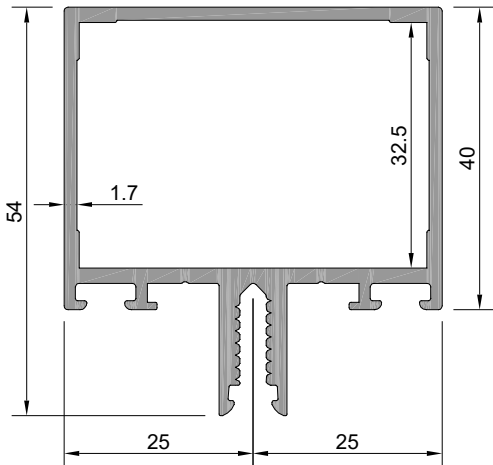

Profil No: F0133

Ağırlık : 1140 gr/m

I_x : 11,79 cm^4

I_y : 12,05 cm^4

w_x : 4,12 cm^3

w_y : 4,82 cm^3



F0310-2



F0501-2

F50 KONDENS SİSTEM SİLİKON CEPHE PROFİLLERİ

F50 CONDENSAT SYSTEM
SILICONE FACADE PROFILE

ÜRÜN TEKNİK ÖZELLİKLERİ
PRODUCT'S TECHNICAL FEATURES

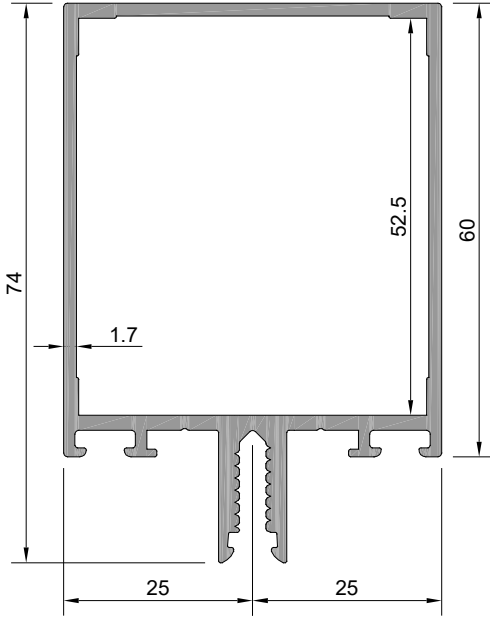

Profil No: F0134

Ağırlık : 1324 gr/m

I_x : 28,79 cm^4

I_y : 16,02 cm^4

w_x : 7,78 cm^3

w_y : 6,41 cm^3



F0310-3



F0311-3

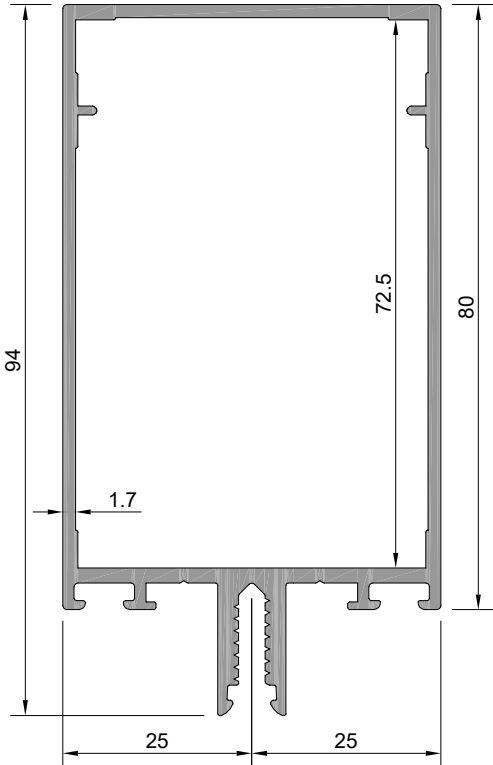

Profil No: F0135

Ağırlık : 1532 gr/m

I_x : 56,17 cm^4

I_y : 20,41 cm^4

w_x : 11,77 cm^3

w_y : 8,16 cm^3



F0310-4



F0311-4

F50 KONDENS SİSTEM SİLİKON CEPHE PROFİLLERİ

F50 CONDENSAT SYSTEM
SILICONE FACADE PROFILE

ÜRÜN TEKNİK ÖZELLİKLERİ
PRODUCT'S TECHNICAL FEATURES

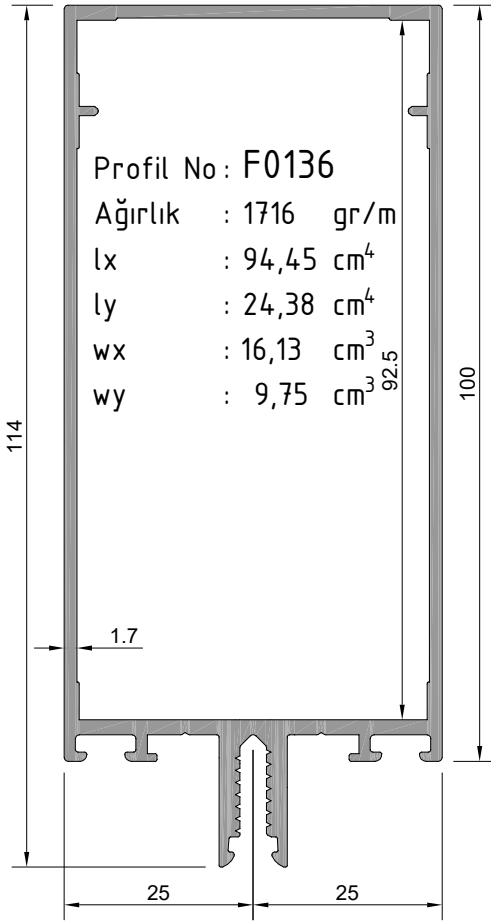

F0310-5



F0311-5

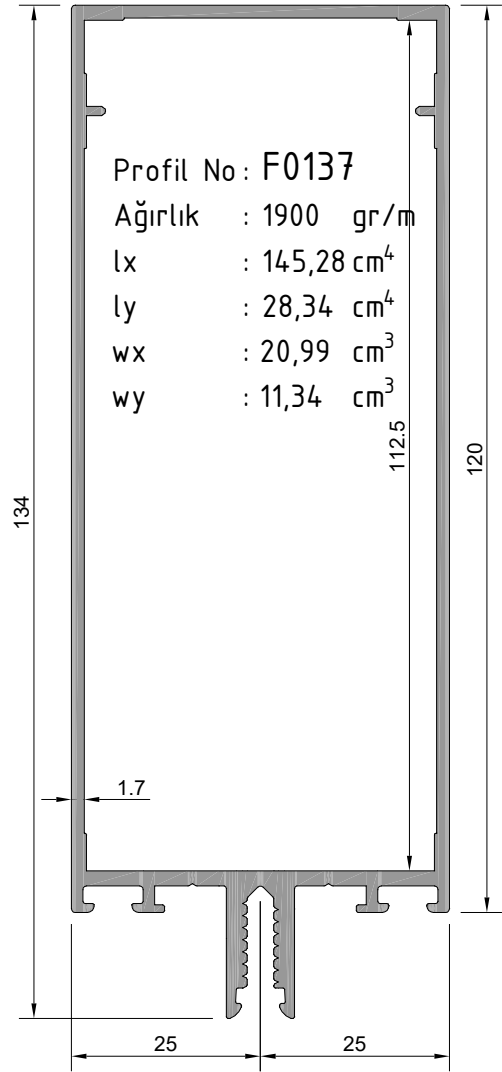

F0310-6



F0311-6

F50 KONDENS SİSTEM SİLİKON CEPHE PROFİLLERİ

F50 CONDENSAT SYSTEM
SILICONE FACADE PROFILE

ÜRÜN TEKNİK ÖZELLİKLERİ
PRODUCT'S TECHNICAL FEATURES

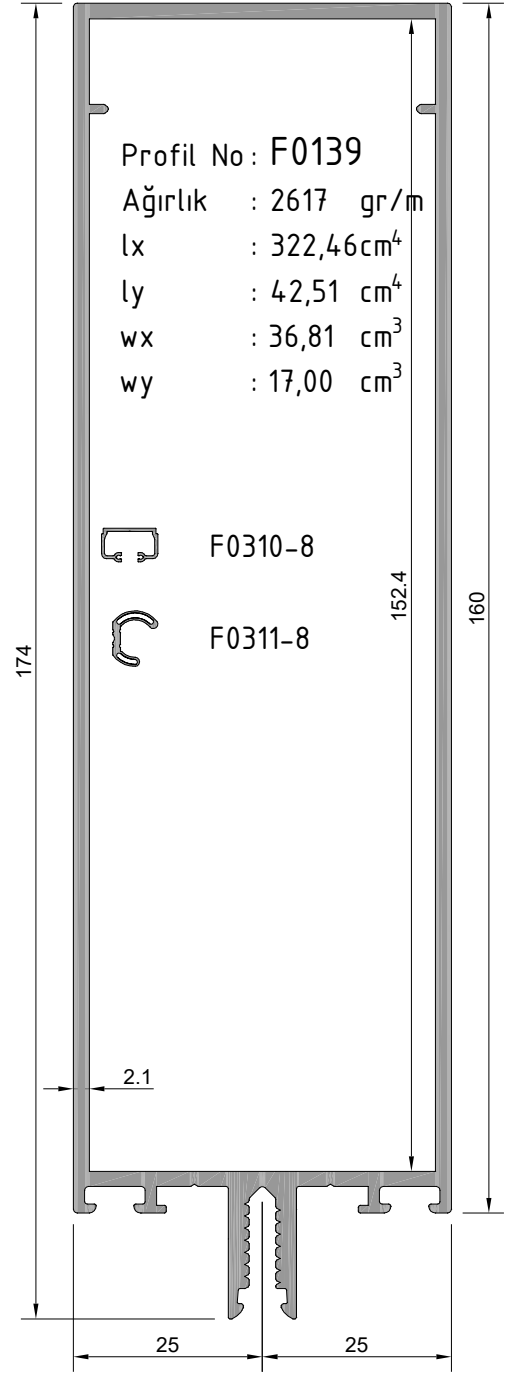
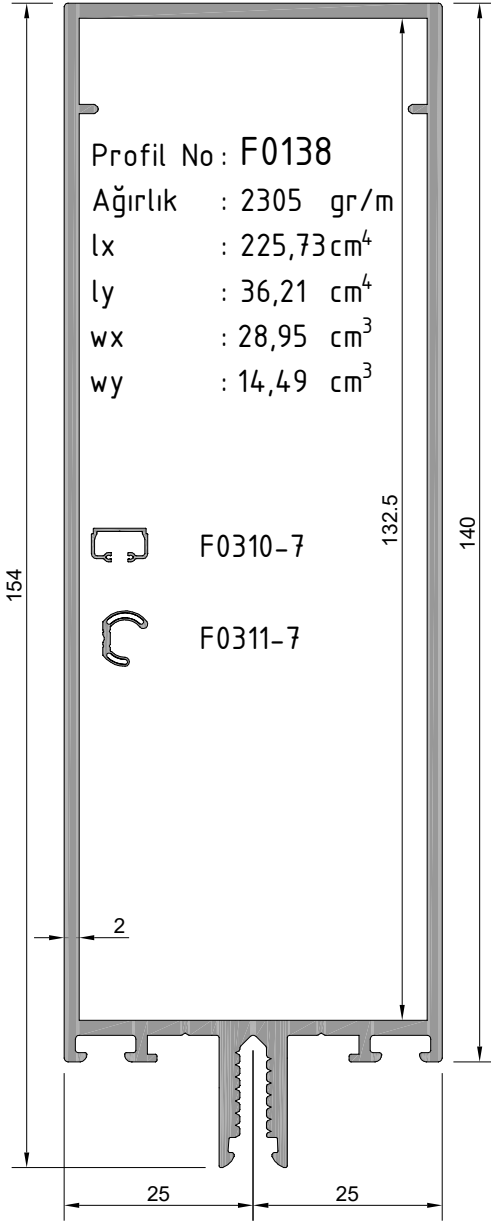

F50 KONDENS SİSTEM SİLİKON CEPHE PROFİLLERİ

F50 CONDENSAT SYSTEM
SILICONE FACADE PROFILE

ÜRÜN TEKNİK ÖZELLİKLERİ
PRODUCT'S TECHNICAL FEATURES

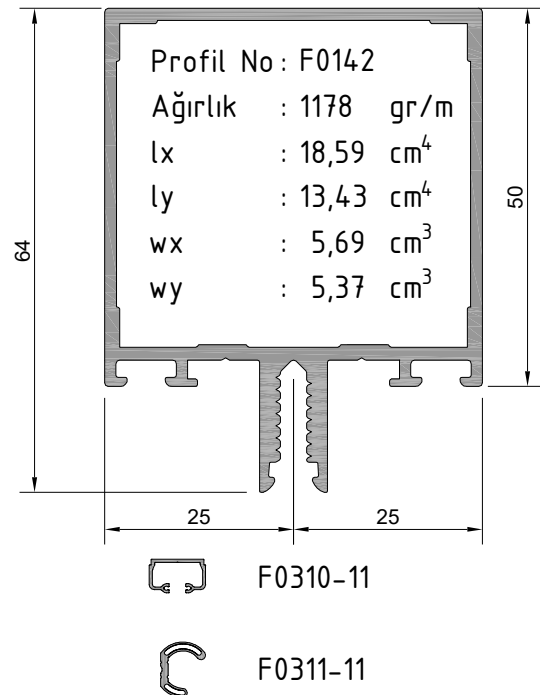
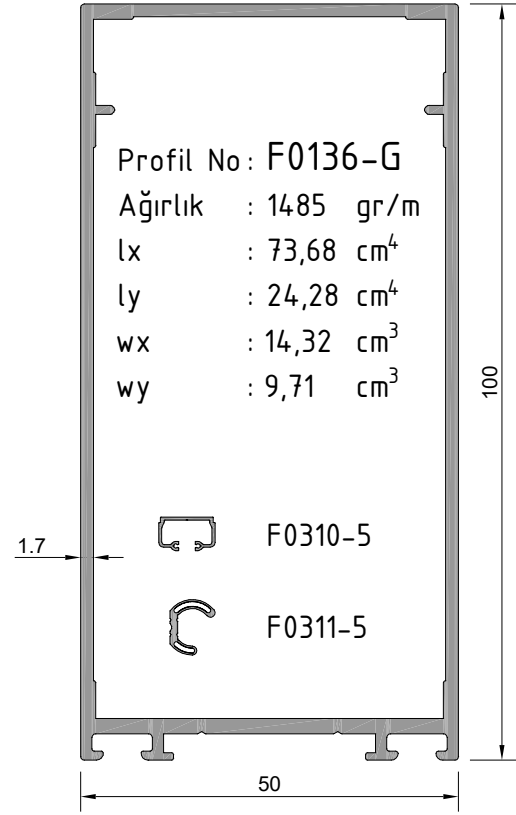
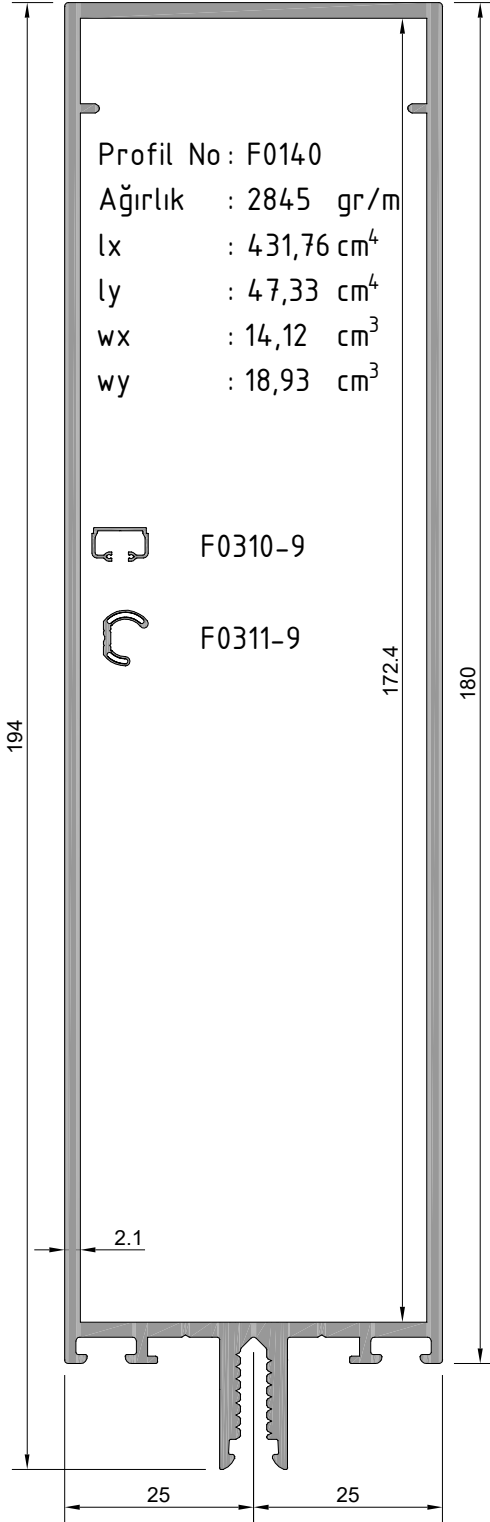

F50 KONDENS SİSTEM SİLİKON CEPHE PROFİLLERİ

F50 CONDENSAT SYSTEM
SILICONE FACADE PROFILE

ÜRÜN TEKNİK ÖZELLİKLERİ
PRODUCT'S TECHNICAL FEATURES

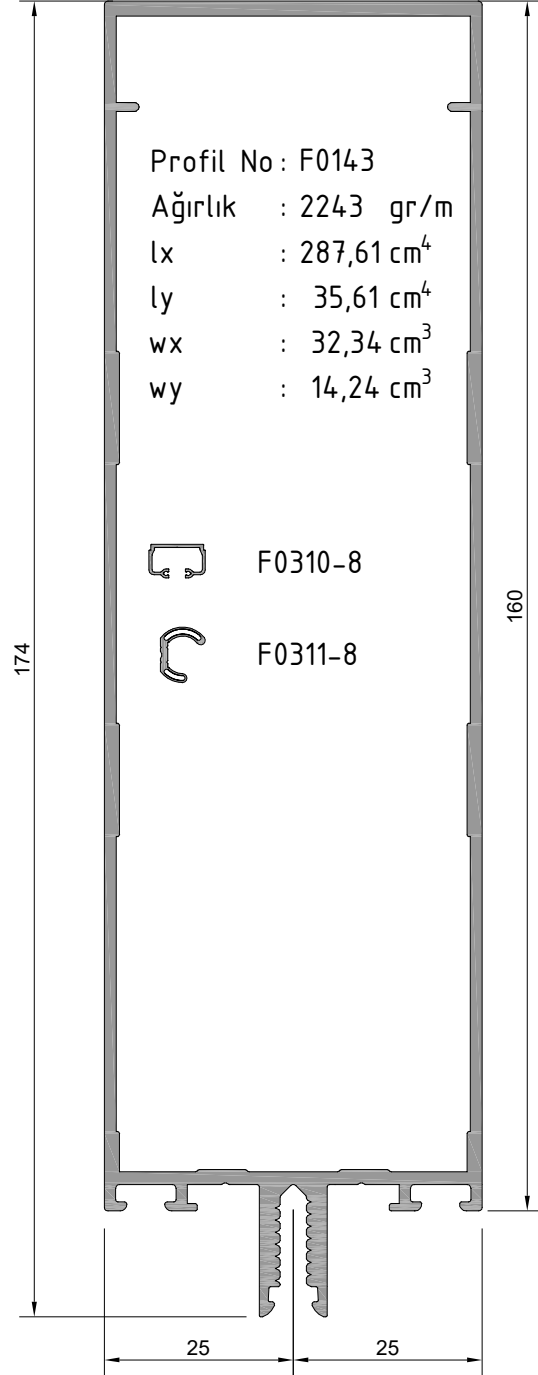
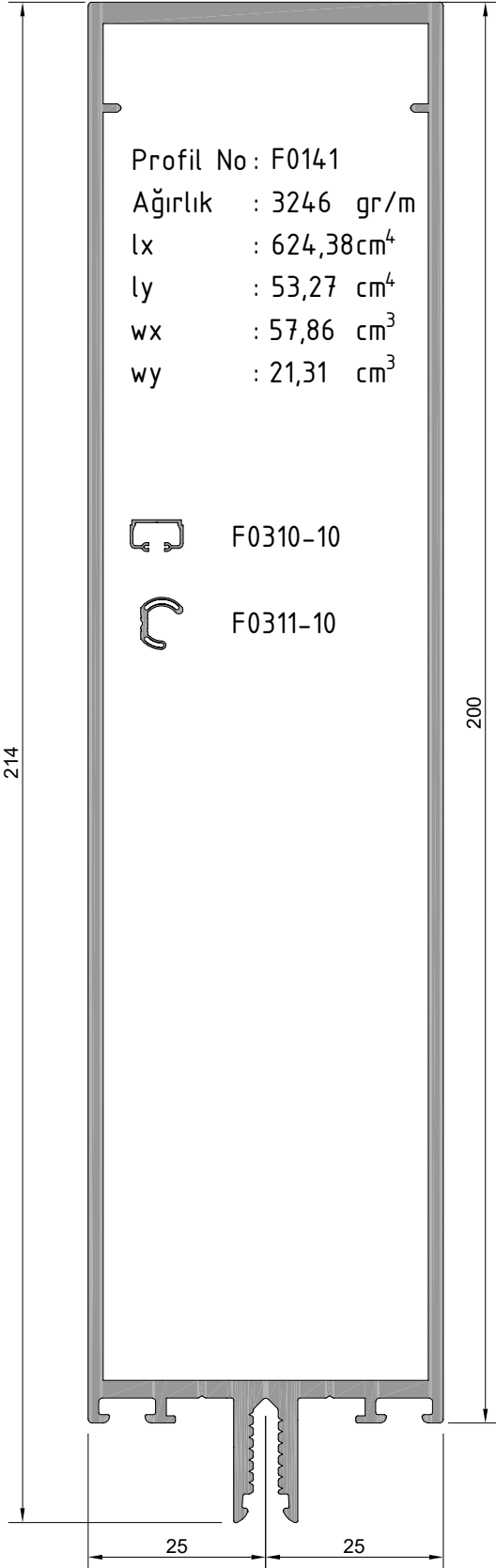

F50 KONDENS SİSTEM SİLİKON CEPHE PROFİLLERİ

F50 CONDENSAT SYSTEM
SILICONE FACADE PROFILE

KLASİK U BAĞL. SİSTEMİ
T-CONNECTOR SYSTEM

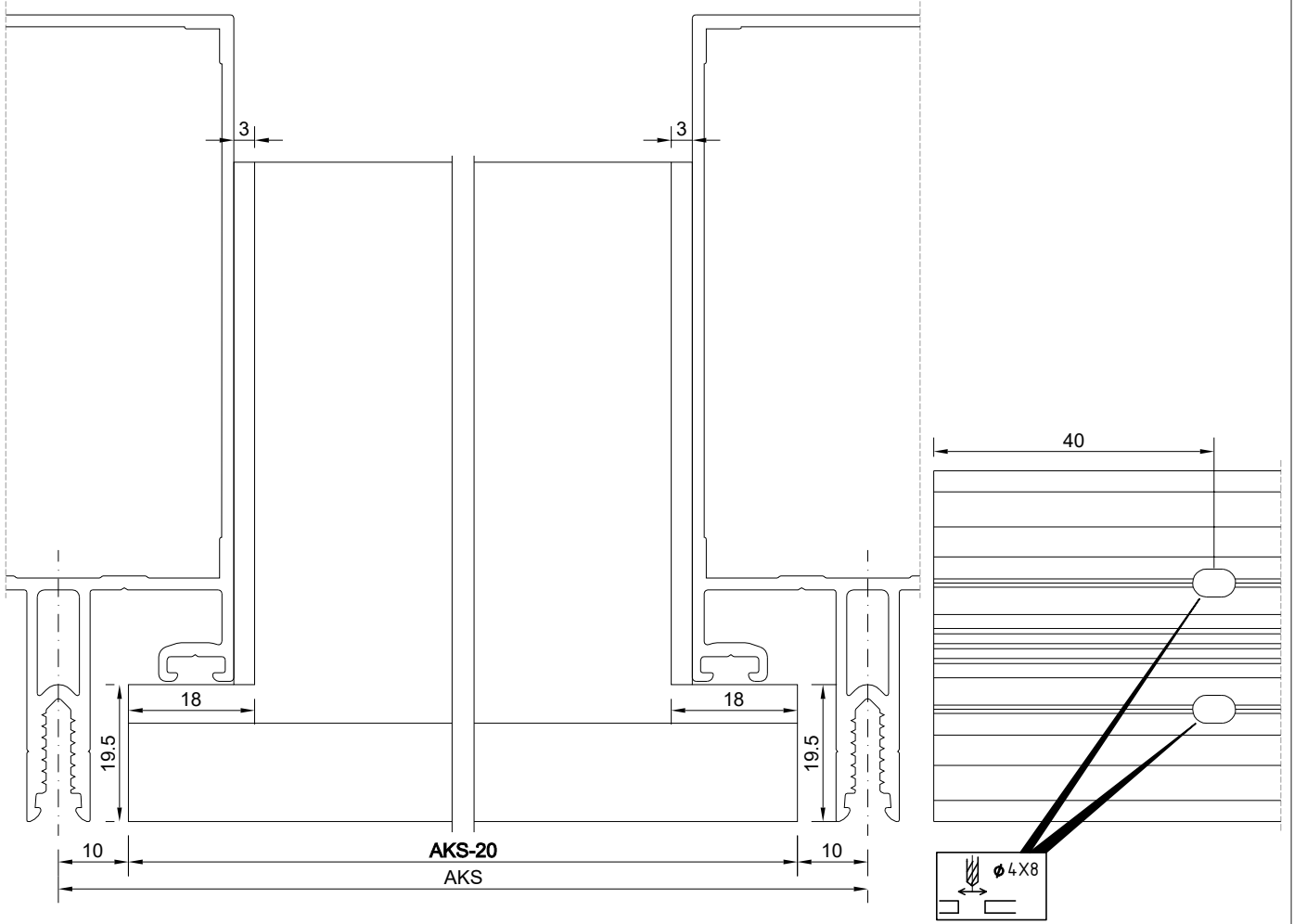

F0310-1	12mm	100 adet/pcs
F0310-2	32mm	100 adet/pcs
F0310-3	52mm	100 adet/pcs
F0310-4	59.4mm	100 adet/pcs
F0310-5	79.4mm	100 adet/pcs
F0310-6	99.4mm	100 adet/pcs
F0310-7	119.4mm	100 adet/pcs
F0310-8	139.4mm	100 adet/pcs
F0310-9	159.4mm	100 adet/pcs
F0310-10	178mm	100 adet/pcs
F0310-11	42mm	100 adet/pcs

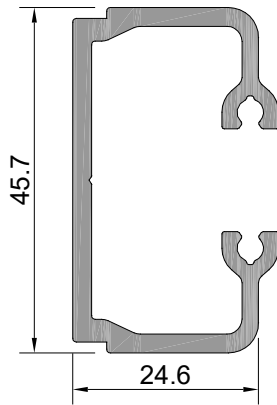

Profil No : F0310
Ağırlık : 841 gr/m

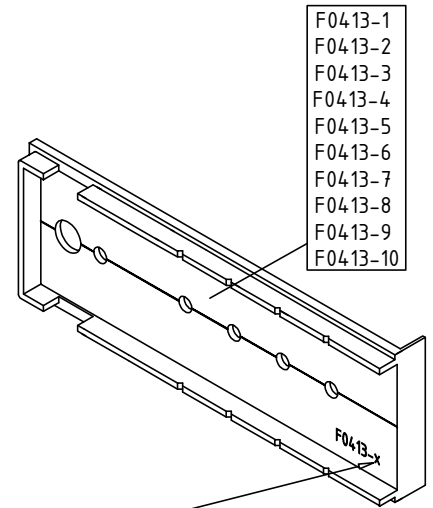

Kullanılan yatay taşıyıcıya göre değişir.

F50 KONDENS SİSTEM SİLİKON CEPHE PROFİLLERİ

F50 CONDENSAT SYSTEM
SILICONE FACADE PROFILE

AÇILI U BAĞL. SİSTEMİ
T-CONNECTOR SYSTEM

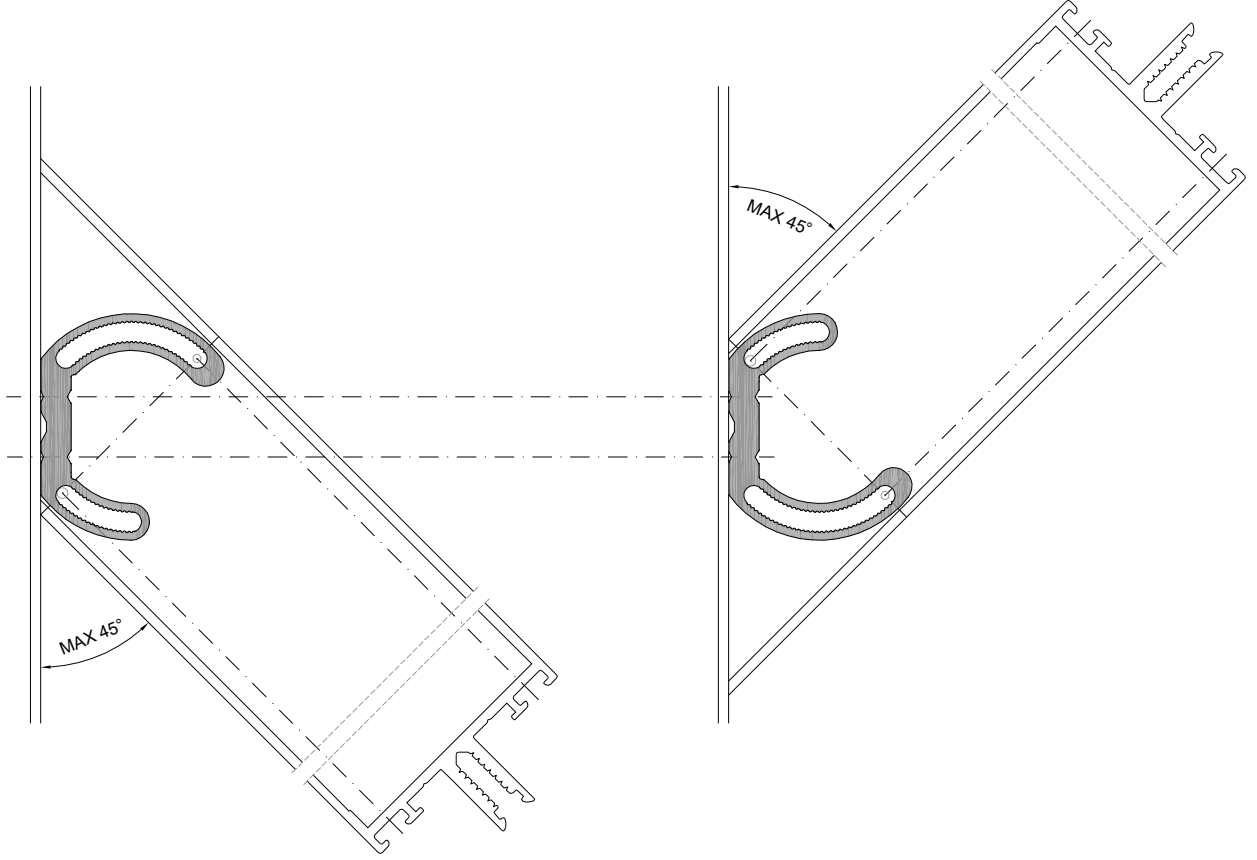

F0311-1	12mm	100 adet/pcs
F0501-2	32mm	100 adet/pcs
F0311-3	52mm	100 adet/pcs
F0311-4	59.4mm	100 adet/pcs
F0311-5	79.4mm	100 adet/pcs
F0311-6	99.4mm	100 adet/pcs
F0311-7	119.4mm	100 adet/pcs
F0311-8	139.4mm	100 adet/pcs
F0311-9	159.4mm	100 adet/pcs
F0311-10	178mm	100 adet/pcs
F0311-11	42mm	100 adet/pcs

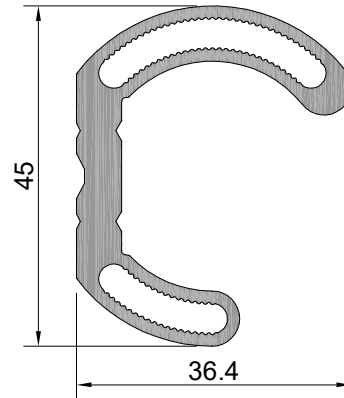

Profil No : F0311

Ağırlık : 947 gr/m

F50 KONDENS SİSTEM SİLİKON CEPHE PROFİLLERİ

F50 CONDENSAT SYSTEM
SILICONE FACADE PROFILE

KLASİK U BAĞL. SİSTEMİ 2
T-CONNECTOR SYSTEM 2

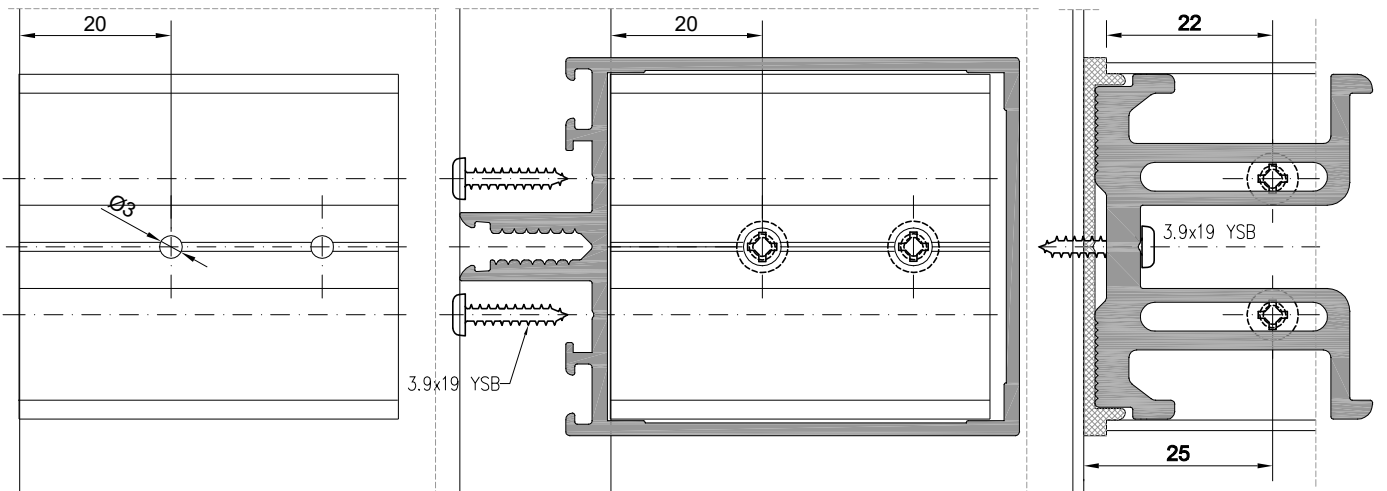
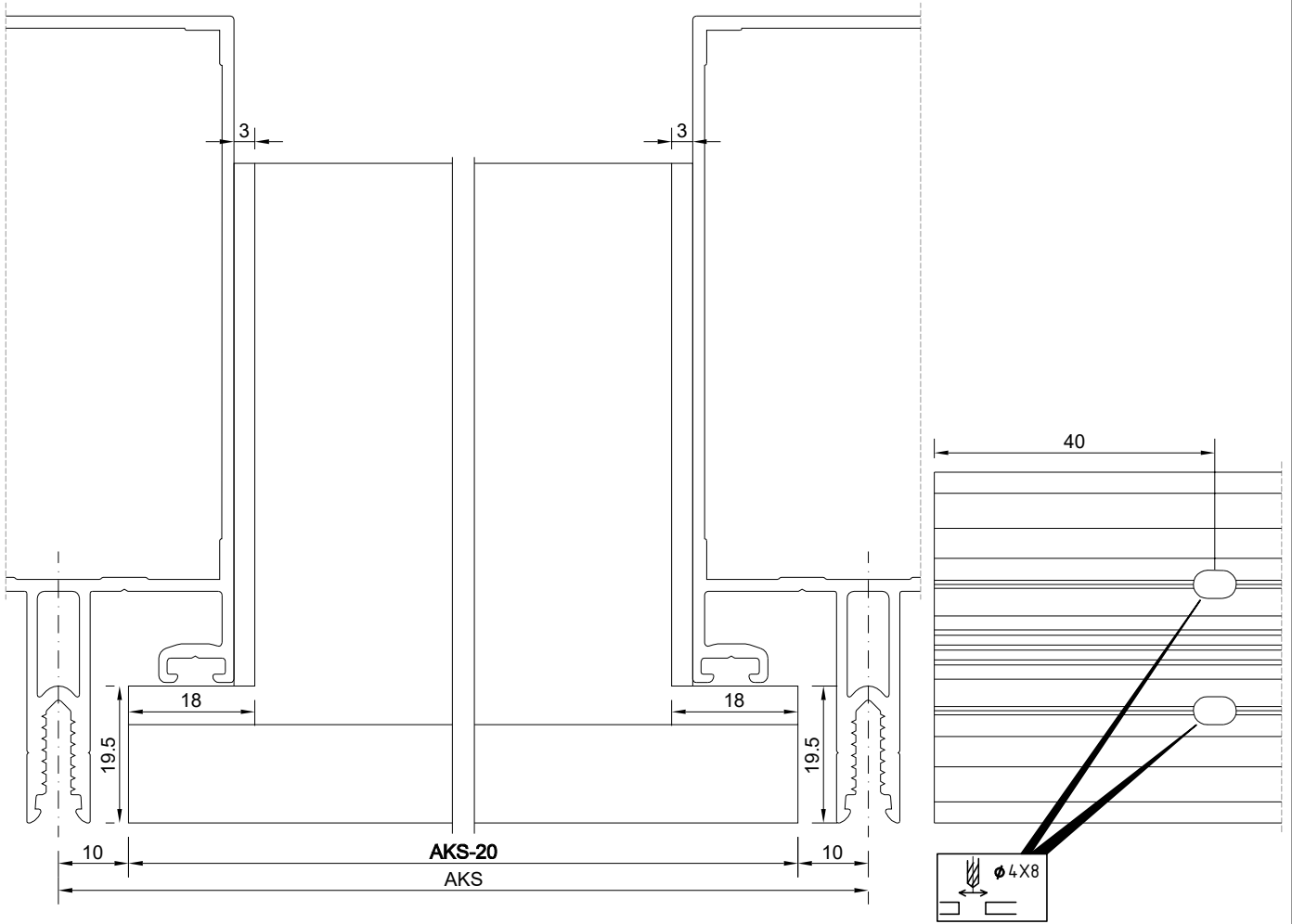

Profil değerleri teoriktir. Ağırlık olarak testimde yapılan tartım geçerlidir.
Profil imalatları TS EN 12020-2 ve TS EN 755-9 toleransı,
Moment değerleri EN 14024'e göre hesaplanmıştır.

Profile values are theoretical pre-shipment weight will be valid.
The tolerances of Profile manufacturing are calculated according to EN 12020-2
and TS EN 755-9; moment values are calculated according to EN 14024.

F50 KONDENS SİSTEM SİLİKON CEPHE PROFİLLERİ

F50 CONDENSAT SYSTEM
SILICONE FAÇADE PROFILE

KLASİK U BAĞL. SİSTEMİ 2
T-CONNECTOR SYSTEM 2

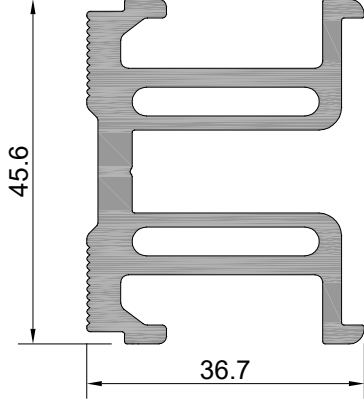

Profil No : F0314
Ağırlık : 1535 gr/m

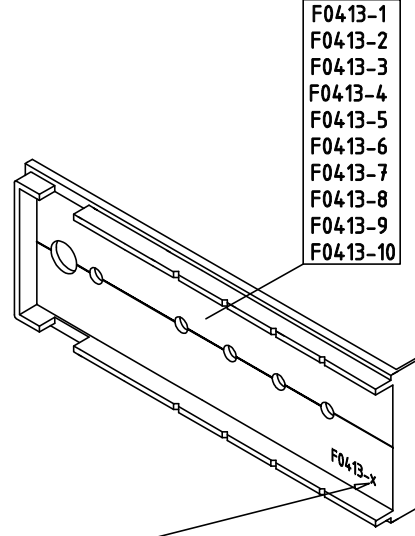

Kullanılan yatay taşıyıcıya göre değişir.

F0314-1	12mm	100 adet/pcs
F0314-2	32mm	100 adet/pcs
F0314-3	52mm	100 adet/pcs
F0314-4	59.4mm	100 adet/pcs
F0314-5	79.4mm	100 adet/pcs
F0314-6	99.4mm	100 adet/pcs
F0314-7	119.4mm	100 adet/pcs
F0314-8	139.4mm	100 adet/pcs
F0314-9	159.4mm	100 adet/pcs
F0314-10	178mm	100 adet/pcs
F0314-11	42mm	100 adet/pcs

F50 KONDENS SİSTEM SİLİKON CEPHE PROFİLLERİ

F50 CONDENSAT SYSTEM
SILICONE FAÇADE PROFILE

KIRLANGIÇ GEÇME SİSTEMİ
T-CONNECTOR SYSTEM

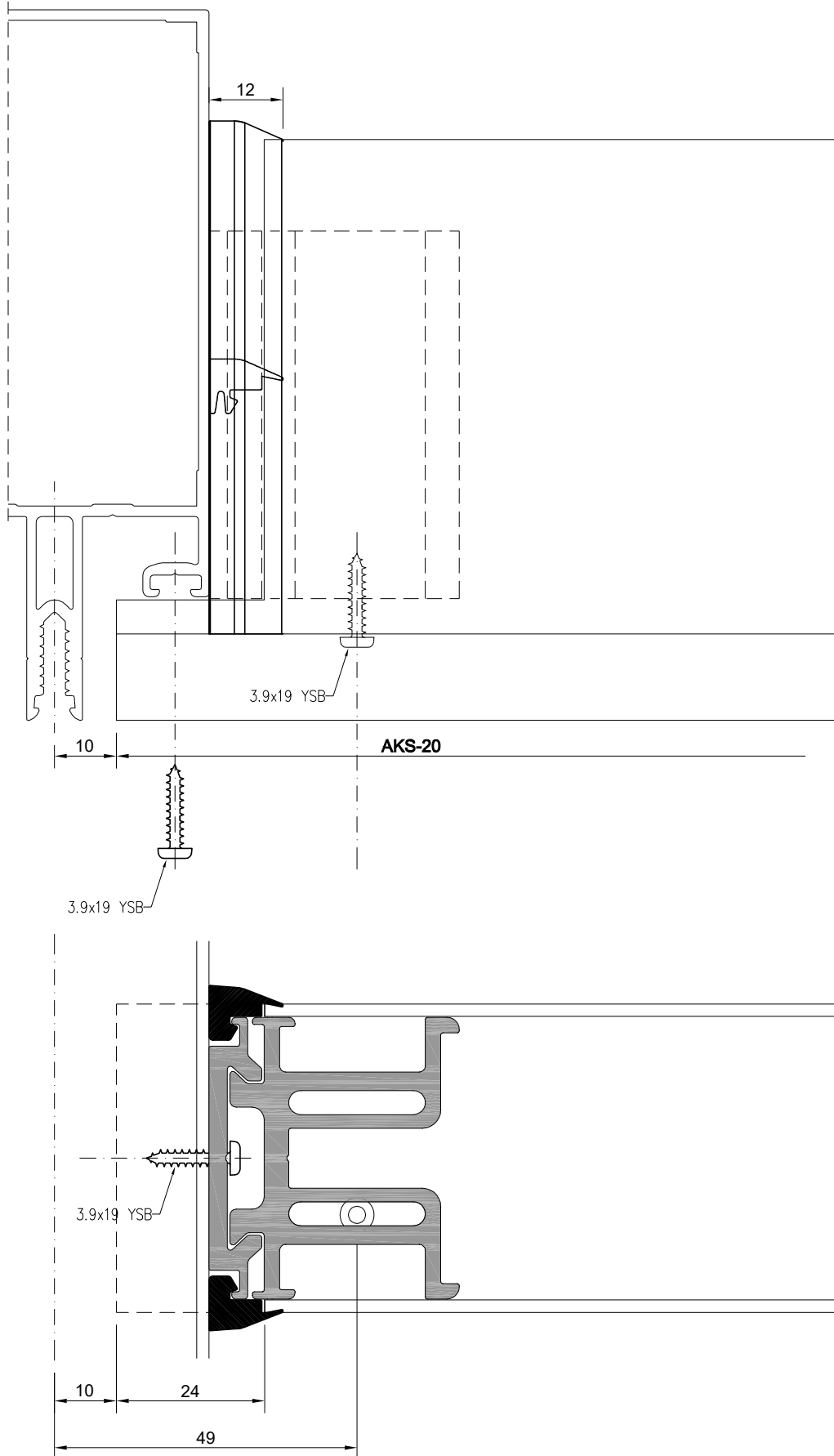

Profil değerleri teoriktir. Ağırlık olarak testimde yapılan tartım geçerlidir.
Profil imalatları TS EN 12020-2 ve TS EN 755-9 toleransı,
Moment değerleri EN 14024'e göre hesaplanmıştır.

Profile values are theoretical pre-shipment weight will be valid.
The tolerances of Profile manufacturing are calculated according to EN 12020-2
and TS EN 755-9; moment values are calculated according to EN 14024.

F50 KONDENS SİSTEM SİLİKON CEPHE PROFİLLERİ

F50 CONDENSAT SYSTEM
SILICONE FAÇADE PROFILE

KIRLANGIÇ GEÇME SİSTEMİ
T-CONNECTOR SYSTEM

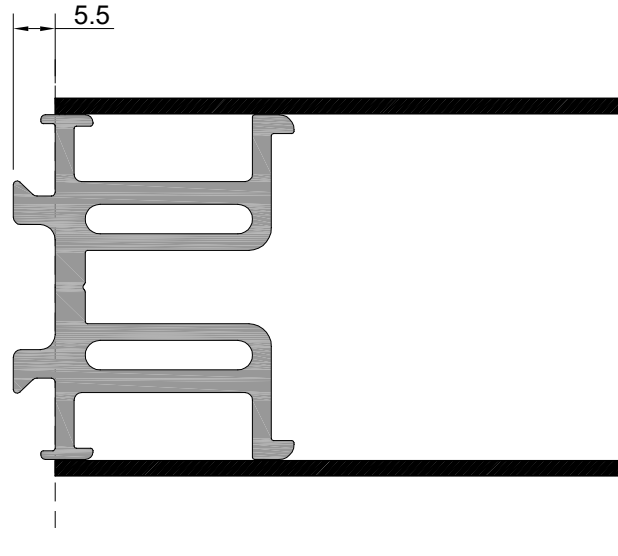
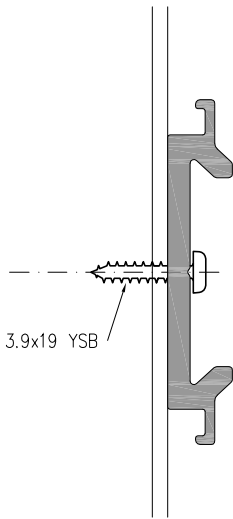
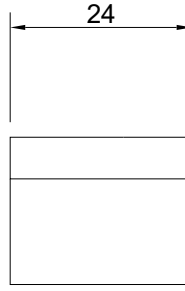
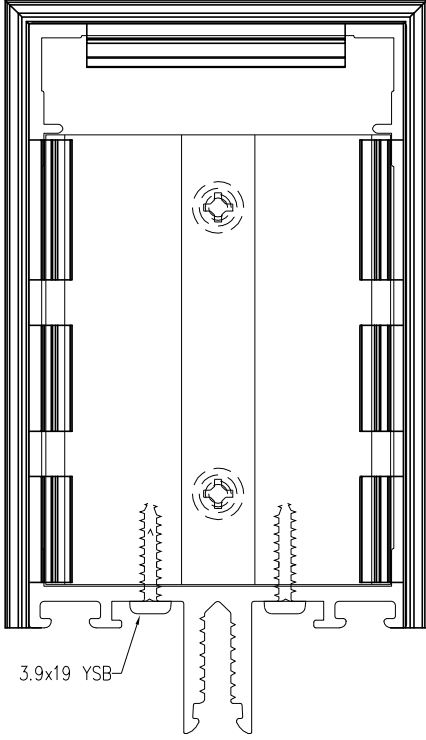

F50 KONDENS SİSTEM SİLİKON CEPHE PROFİLLERİ

F50 CONDENSAT SYSTEM
SILICONE FACADE PROFILE

KIRLANGIÇ GEÇME SİSTEMİ
T-CONNECTOR SYSTEM

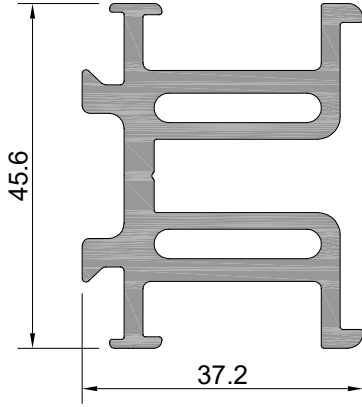

Profil No : F0312
Ağırlık : 1500 gr/m

F0312-1	12mm	100 adet/pcs
F0312-2	32mm	100 adet/pcs
F0312-3	52mm	100 adet/pcs
F0312-4	59.4mm	100 adet/pcs
F0312-5	79.4mm	100 adet/pcs
F0312-6	99.4mm	100 adet/pcs
F0312-7	119.4mm	100 adet/pcs
F0312-8	139.4mm	100 adet/pcs
F0312-9	159.4mm	100 adet/pcs
F0312-10	178mm	100 adet/pcs
F0312-11	42mm	100 adet/pcs

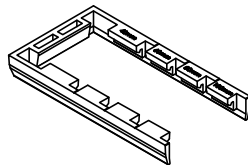
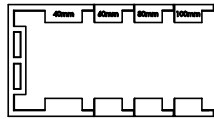

F0412-1
40-60-80-100 lük için
yaka fitili

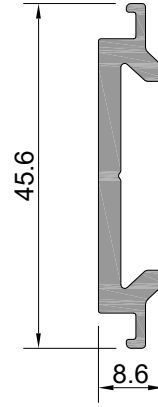

Profil No : F0313
Ağırlık : 446 gr/m

F0313-1	12mm	100 adet/pcs
F0313-2	32mm	100 adet/pcs
F0313-3	52mm	100 adet/pcs
F0313-4	59.4mm	100 adet/pcs
F0313-5	79.4mm	100 adet/pcs
F0313-6	99.4mm	100 adet/pcs
F0313-7	119.4mm	100 adet/pcs
F0313-8	139.4mm	100 adet/pcs
F0313-9	159.4mm	100 adet/pcs
F0313-10	178mm	100 adet/pcs
F0313-11	42mm	100 adet/pcs

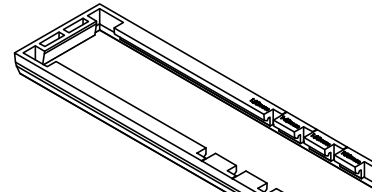
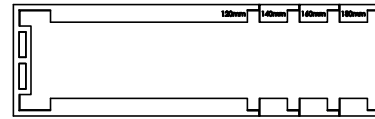

F0412-2
120-140-160-180 lik için
yaka fitili

F50 KONDENS SİSTEM SİLİKON CEPHE PROFİLLERİ

F50 CONDENSAT SYSTEM
SILICONE FACADE PROFILE

ÜRÜN TEKNİK ÖZELLİKLERİ
PRODUCT'S TECHNICAL FEATURES

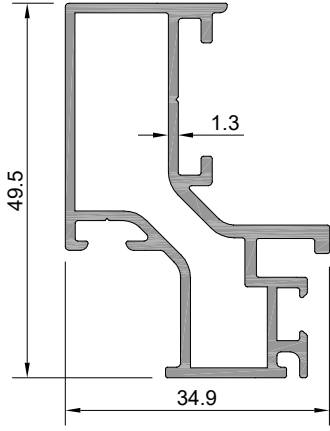

Profil No: SC0201
Ağırlık : 734 gr/m



SC0308-a



SC0304-a



SC0307-a

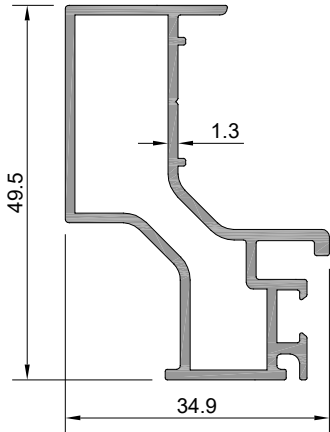

Profil No: SC0202
Ağırlık : 636 gr/m



SC0308-a

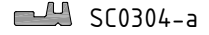

SC0304-a



SC0307-a

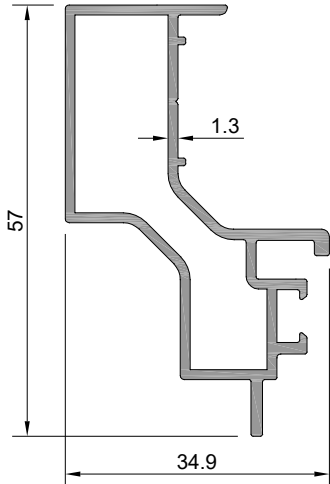

Profil No: SC0203
Ağırlık : 643 gr/m



SC0308-a



SC0304-a



SC0307-a

F50 KONDENS SİSTEM SİLİKON CEPHE PROFİLLERİ

F50 CONDENSAT SYSTEM
SILICONE FACADE PROFILE

ÜRÜN TEKNİK ÖZELLİKLERİ
PRODUCT'S TECHNICAL FEATURES

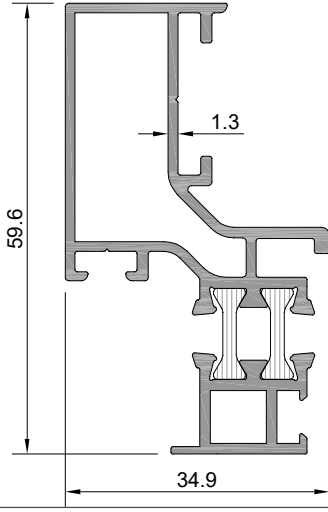

Profil No : SC0204

Ağırlık PVC : 970 gr/m

Ağırlık POLY: 963 gr/m



SC0308-b



SC0304-a



SC0309-a

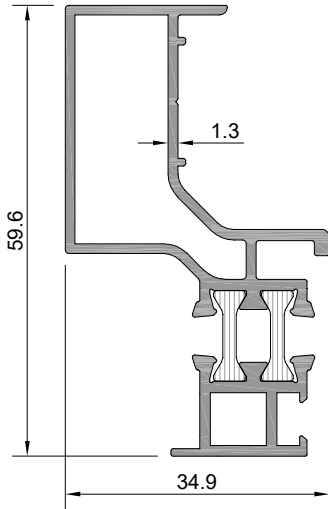

Profil No : SC0205

Ağırlık PVC : 894 gr/m

Ağırlık POLY: 886 gr/m



SC0308-b



SC0304-a



SC0309-a

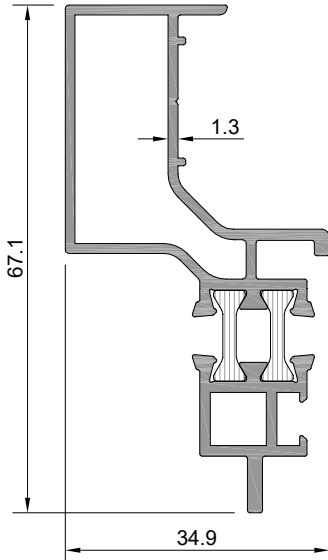

Profil No : SC0206

Ağırlık PVC : 924 gr/m

Ağırlık POLY: 917 gr/m



SC0308-b



SC0304-a



SC0309-a

F50 KONDENS SİSTEM SİLİKON CEPHE PROFİLLERİ

F50 CONDENSAT SYSTEM
SILICONE FACADE PROFILE

ÜRÜN TEKNİK ÖZELLİKLERİ
PRODUCT'S TECHNICAL FEATURES

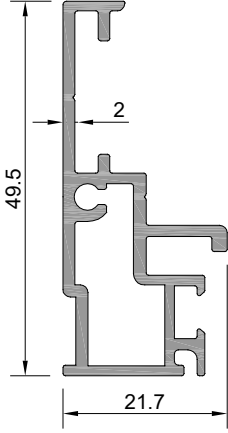

Profil No: SC0209
Ağırlık : 593 gr/m

 SC0304-a

 SC0307-a

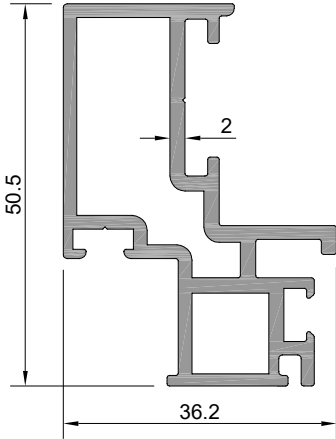

Profil No: SC0210
Ağırlık : 1001 gr/m

 SC0308-a

 SC0304-a

 SC0307-a

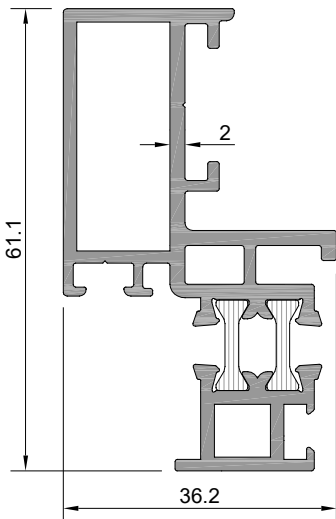

Profil No: SC0214

Ağırlık PVC : 1275 gr/m

Ağırlık POLY: 1268 gr/m

 SC0308-b

 SC0304-a

 SC0309-a

F50 KONDENS SİSTEM SİLİKON CEPHE PROFİLLERİ

F50 CONDENSAT SYSTEM
SILICONE FACADE PROFILE

ÜRÜN TEKNİK ÖZELLİKLERİ
PRODUCT'S TECHNICAL FEATURES

Profil No: SC0215

Ağırlık PVC : 1365 gr/m

Ağırlık POLY: 1350 gr/m

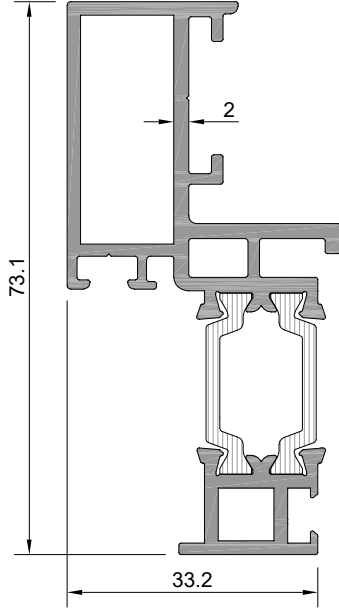

Profil No: SC0216

Ağırlık PVC : 1060 gr/m

Ağırlık POLY: 1045 gr/m

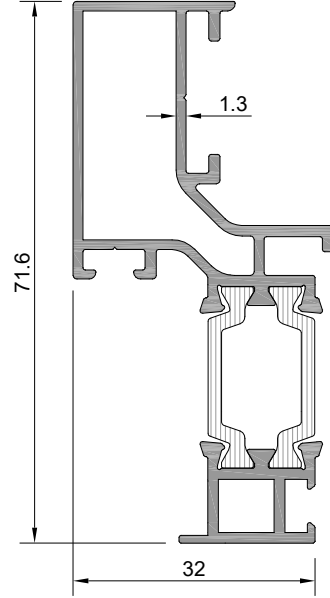

SC0308-b

SC0304-a



SC0309-a



SC0308-b

SC0304-a



SC0309-a

Profil No: SC0218

Ağırlık : 1250 gr/m

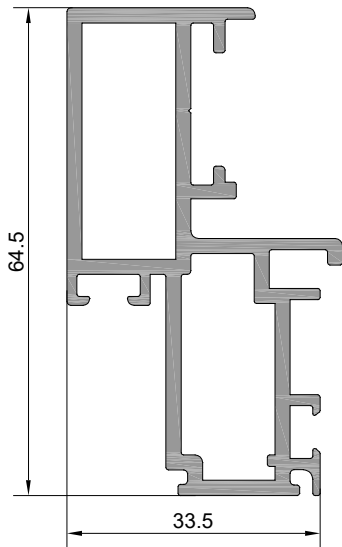

Profil No: SC0219

Ağırlık PVC : 1449 gr/m

Ağırlık POLY: 1442 gr/m

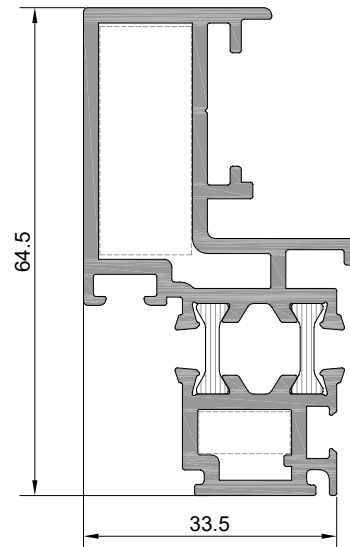

SC0308-b

SC0304-a



SC0308-g



SC0308-b

SC0304-a



SC0308-l

Profil değerleri teoriktir. Ağırlık olarak testimde yapılan tartım geçerlidir.
Profil imalatları TS EN 12020-2 ve TS EN 755-9 toleransı,
Moment değerleri EN 14024'e göre hesaplanmıştır.

Profile values are theoretical pre-shipment weight will be valid.
The tolerances of Profile manufacturing are calculated according to EN 12020-2
and TS EN 755-9; moment values are calculated according to EN 14024.

F50 KONDENS SİSTEM SİLİKON CEPHE PROFİLLERİ

F50 CONDENSAT SYSTEM
SILICONE FACADE PROFILE

PANEL CAM KOMBİNASYONU
GLASS PANEL COMBINATION

SC0201

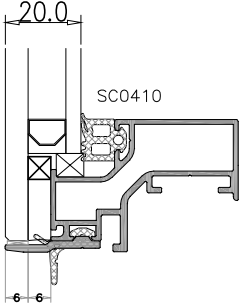

SC0210

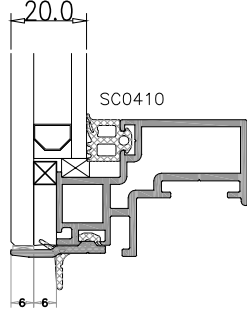

SC0204

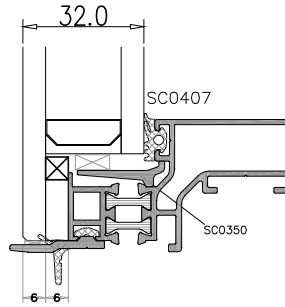

SC0214

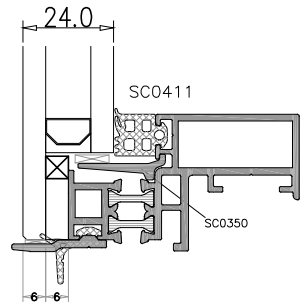
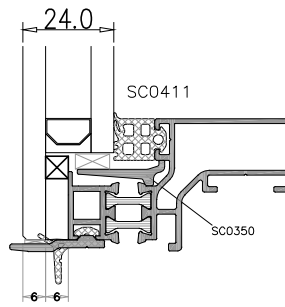
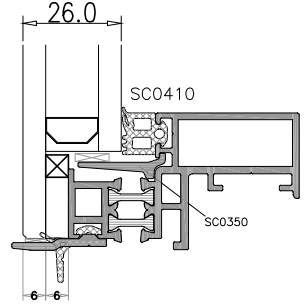
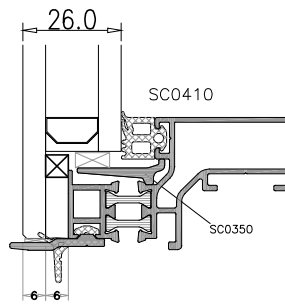
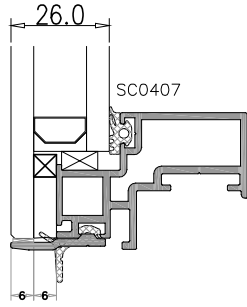
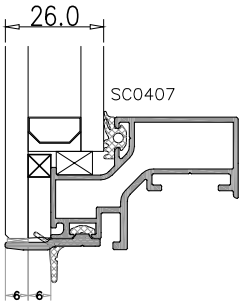
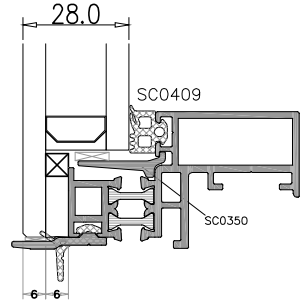
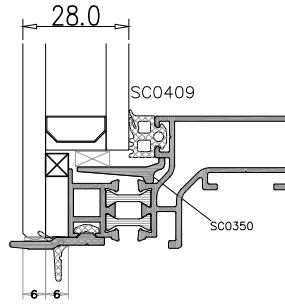
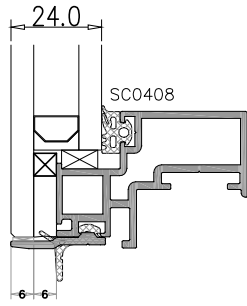
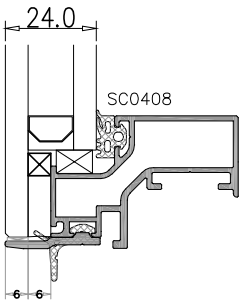
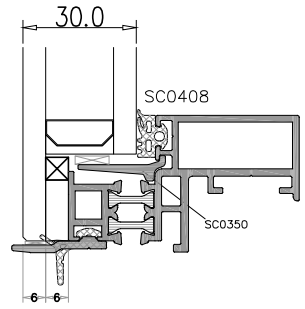
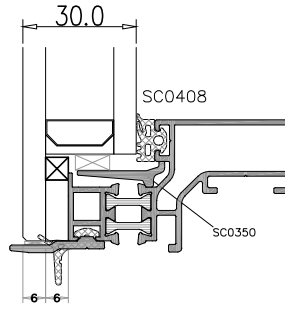
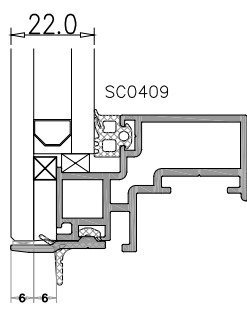
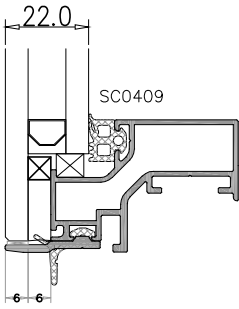
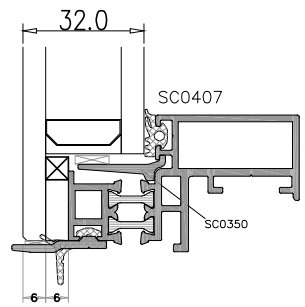

Profil değerleri teoriktir. Ağırlık olarak testimde yapılan tartım geçerlidir.
Profil imalatları TS EN 12020-2 ve TS EN 755-9 toleransı,
Moment değerleri EN 14024'e göre hesaplanmıştır.

Profile values are theoretical pre-shipment weight will be valid.
The tolerances of Profile manufacturing are calculated according to EN 12020-2
and TS EN 755-9; moment values are calculated according to EN 14024.

F50 KONDENS SİSTEM SİLİKON CEPHE PROFİLLERİ

F50 CONDENSAT SYSTEM
SILICONE FACADE PROFILE

PANEL CAM KOMBİNASYONU
GLASS PANEL COMBINATION

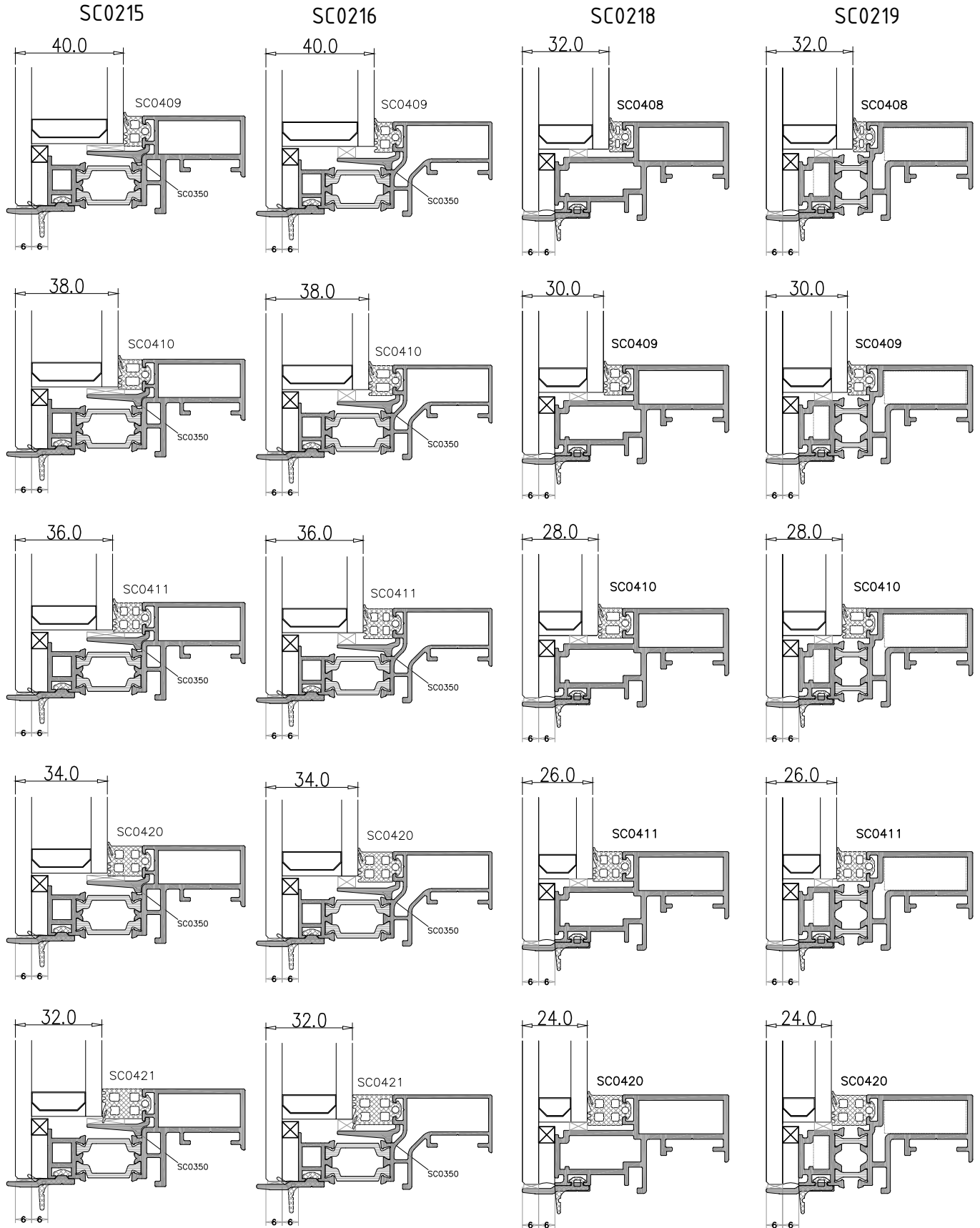

Profil değerleri teoriktir. Ağırlık olarak testimde yapılan tartım geçerlidir.
Profil imatları TS EN 12020-2 ve TS EN 755-9 toleransı,
Moment değerleri EN 14024'e göre hesaplanmıştır.

Profile values are theoretical pre-shipment weight will be valid.
The tolerances of Profile manufacturing are calculated according to EN 12020-2
and TS EN 755-9; moment values are calculated according to EN 14024.

F50 KONDENS SİSTEM SİLİKON CEPHE PROFİLLERİ

F50 CONDENSAT SYSTEM
SILICONE FACADE PROFILE

ÜRÜN TEKNİK ÖZELLİKLERİ
PRODUCT'S TECHNICAL FEATURES

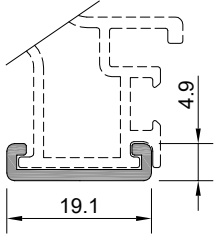

Profil No: SC0207
Ağırlık : 109 gr/m

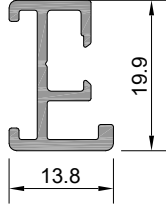

Profil No: SC0217
Ağırlık : 242gr/m

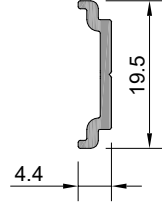

Profil No: SC0303
Ağırlık : 96 gr/m

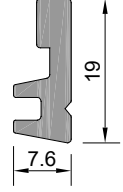

Profil No: SC0304
Ağırlık : 238 gr/m

SC0304-a	50 mm	100 adet/pcs
----------	-------	--------------

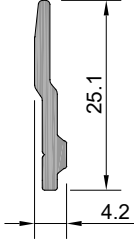

Profil No: SC0312
Ağırlık : 147 gr/m

SC0312-a	50 mm	100 adet/pcs
----------	-------	--------------

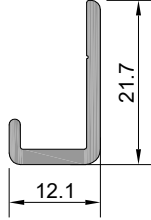

Profil No: SC0343
Ağırlık : 173 gr/m

SC0343-a	50 mm	100 adet/pcs
----------	-------	--------------

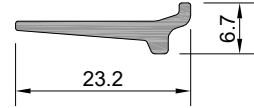

Profil No: SC0350
Ağırlık : 140 gr/m

SC0350-a	50 mm	100 adet/pcs
----------	-------	--------------

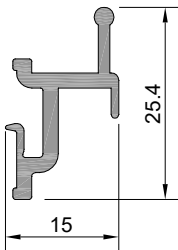

Profil No: SC0344
Ağırlık : 244 gr/m

SC0344-a	50 mm	100 adet/pcs
----------	-------	--------------

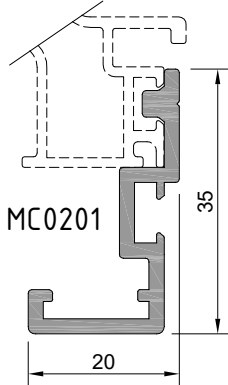

Profil No: MC0201
Ağırlık : 397 gr/m

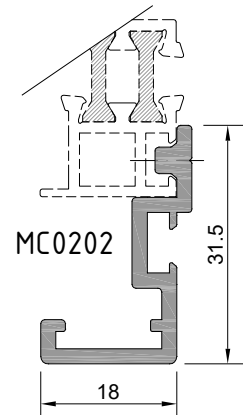

Profil No: MC0202
Ağırlık : 378 gr/m

F50 KONDENS SİSTEM SİLİKON CEPHE PROFİLLERİ

F50 CONDENSAT SYSTEM
SILICONE FACADE PROFILE

KÖŞE PRES PR.
PRES CORNER PROFILE

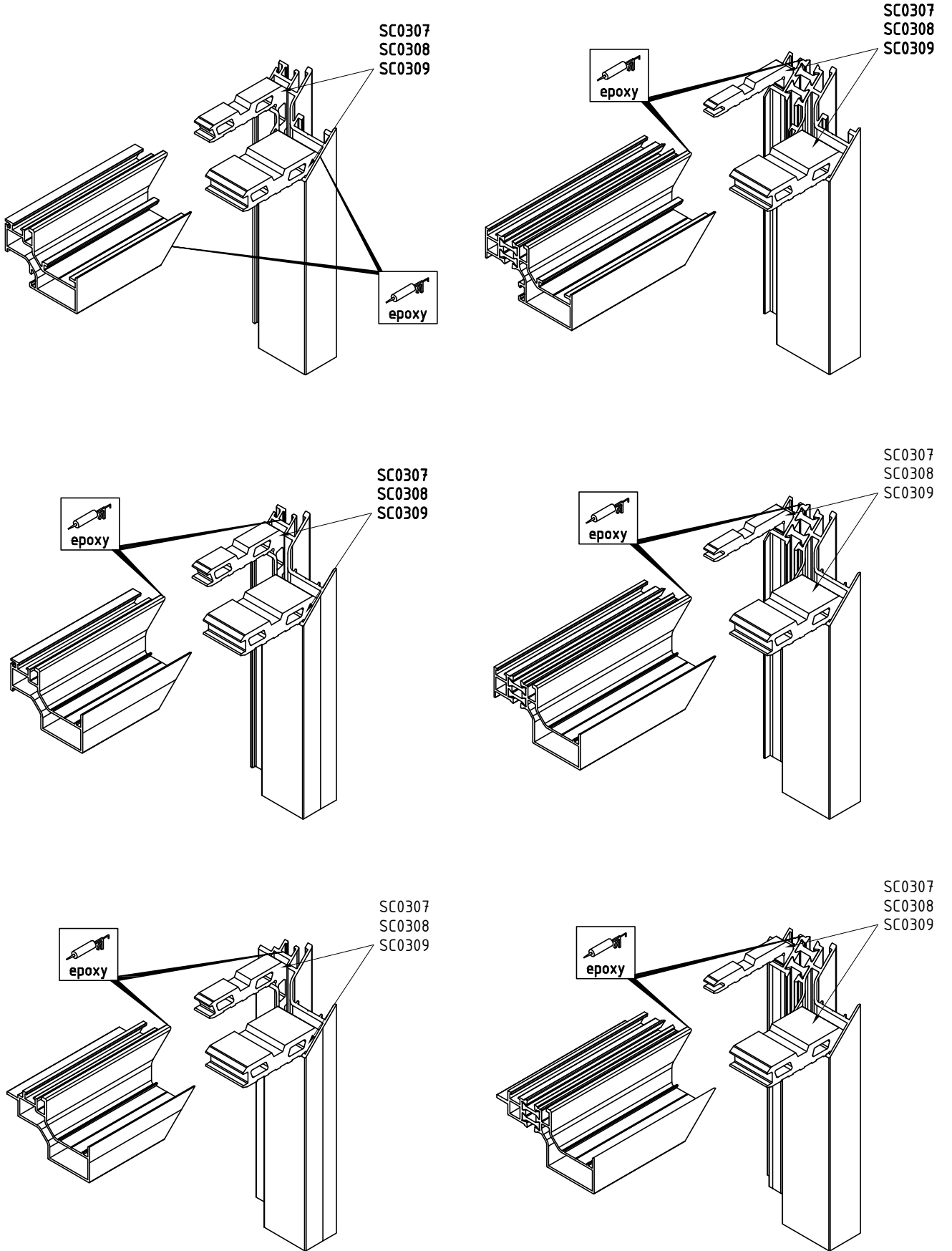

F50 KONDENS SİSTEM SİLİKON CEPHE PROFİLLERİ

F50 CONDENSAT SYSTEM
SILICONE FACADE PROFILE

ÜRÜN TEKNİK ÖZELLİKLERİ
PRODUCT'S TECHNICAL FEATURES

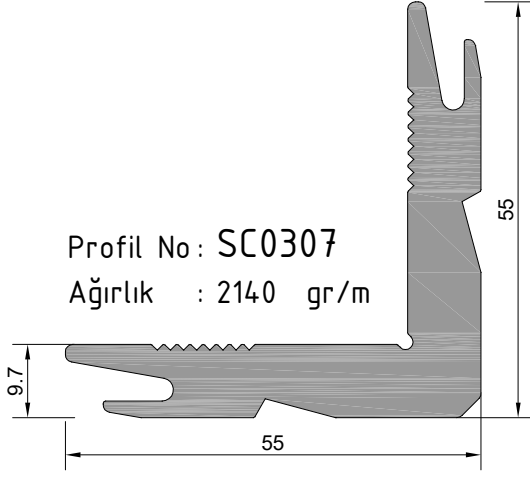

SC0307-a	10.25mm	100 adet/pcs	SC0307-f	25.6mm	100 adet/pcs
SC0307-b	27mm	100 adet/pcs	SC0307-g	6mm	100 adet/pcs
SC0307-c	8.5mm	100 adet/pcs	SC0307-h	4.7mm	100 adet/pcs
SC0307-d	23.9mm	100 adet/pcs	SC0307-ı	26.28mm	100 adet/pcs
SC0307-e	6.3mm	100 adet/pcs	SC0307-j	29.5mm	100 adet/pcs

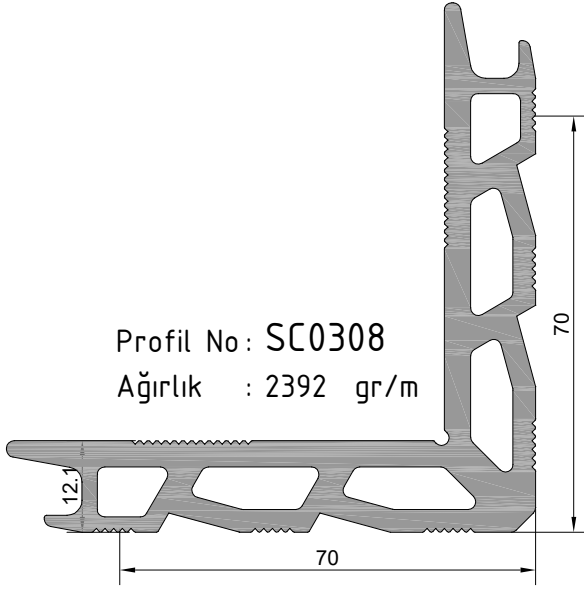

SC0308-a	25.68mm	100 adet/pcs
SC0308-b	29.74mm	100 adet/pcs
SC0308-c	24.36mm	100 adet/pcs
SC0308-d	10.30mm	100 adet/pcs
SC0308-e	6.70mm	100 adet/pcs
SC0308-f	23mm	100 adet/pcs
SC0308-g	19.50mm	100 adet/pcs

SC0308-h	9.9mm	100 adet/pcs
SC0308-j	9.2mm	100 adet/pcs
SC0308-k	39mm	100 adet/pcs
SC0308-l	5.6mm	100 adet/pcs

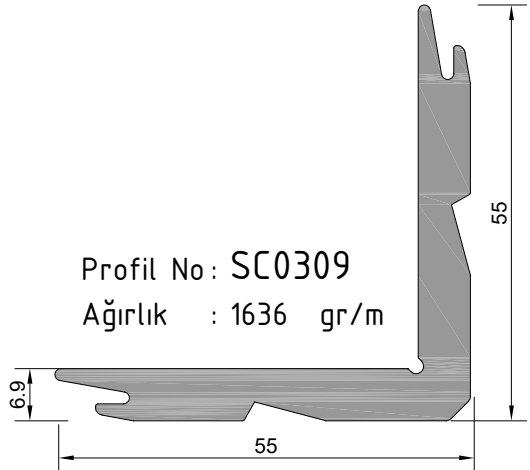

SC0309-a	6.5mm	100 adet/pcs	SC0309-f	4.7mm	100 adet/pcs
SC0309-b	8.5mm	100 adet/pcs	SC0309-g	54.2mm	100 adet/pcs
SC0309-c	18.9mm	100 adet/pcs	SC0309-h	23.8mm	100 adet/pcs
SC0309-d	20mm	100 adet/pcs	SC0309-ı	48.2mm	100 adet/pcs
SC0309-e	25.3mm	100 adet/pcs	SC0309-j	52.8mm	100 adet/pcs

F50 KONDENS SİSTEM SİLİKON CEPHE PROFİLLERİ

F50 CONDENSAT SYSTEM
SILICONE FACADE PROFILE

ÜRÜN TEKNİK ÖZELLİKLERİ
PRODUCT'S TECHNICAL FEATURES

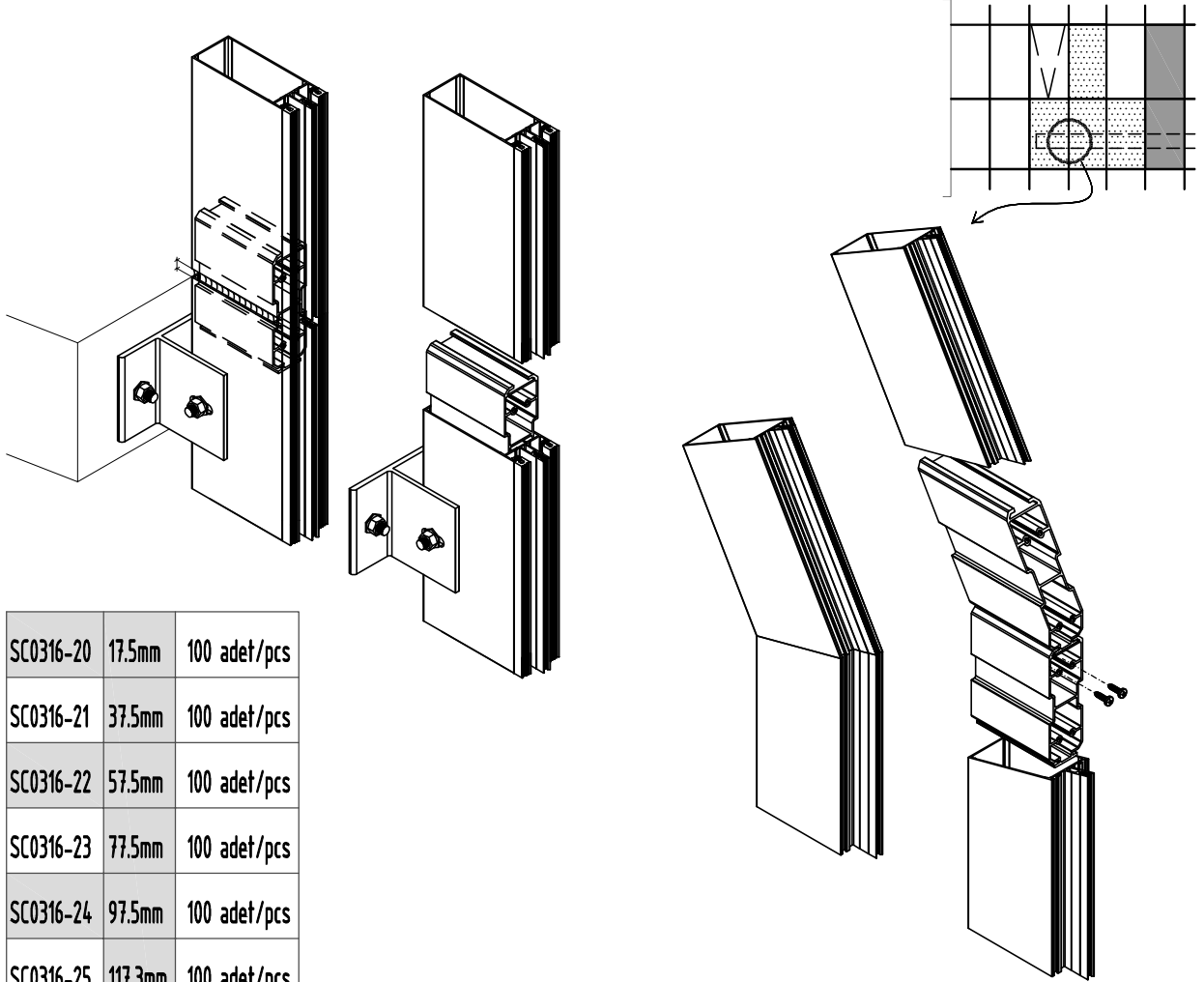

SC0316-20	17.5mm	100 adet/pcs
SC0316-21	37.5mm	100 adet/pcs
SC0316-22	57.5mm	100 adet/pcs
SC0316-23	77.5mm	100 adet/pcs
SC0316-24	97.5mm	100 adet/pcs
SC0316-25	117.3mm	100 adet/pcs
SC0316-26	137.3mm	100 adet/pcs
SC0316-27	157.1mm	100 adet/pcs
SC0316-28	177.1mm	100 adet/pcs

Profil No : SC0316

Ağırlık : 3079 gr/m

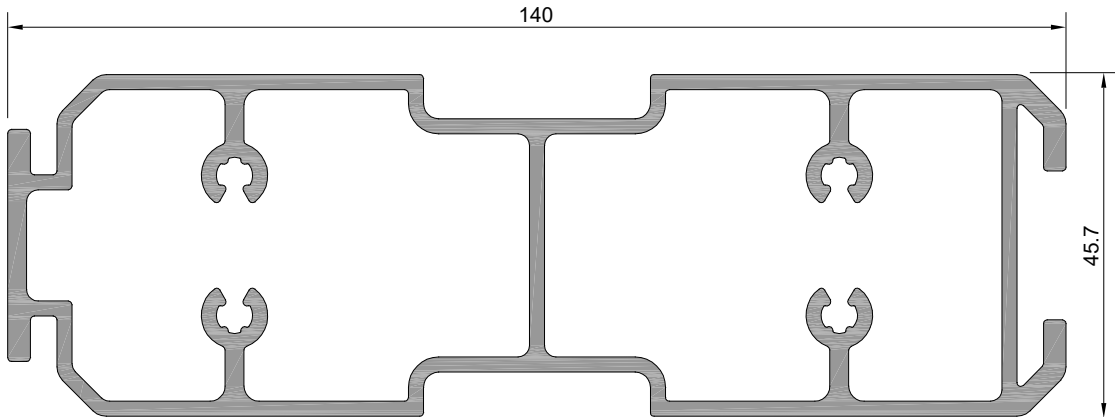

F50 KONDENS SİSTEM
SİLİKON CEPHE
F50 CONDENSAT SYSTEM
SILICONE FACADE

YAN BITİM - SABİT
WALL CONNECTION-FIXED

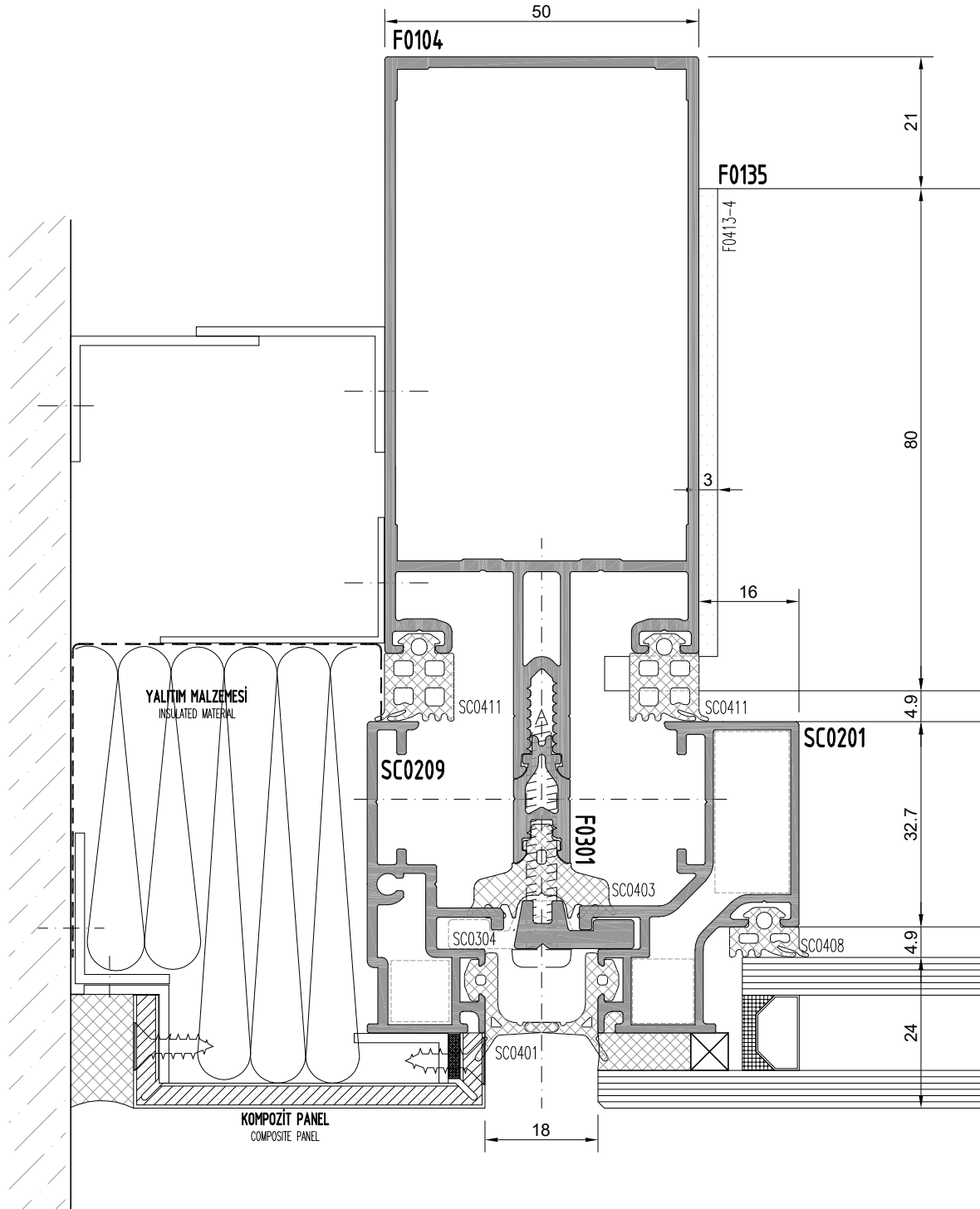
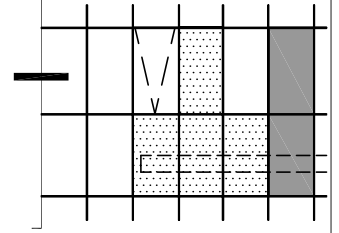

F50 KONDENS SİSTEM
SİLİKON CEPHE
F50 CONDENSAT SYSTEM
SILICONE FACADE

KANAT - SPANDREL
SASH-SPANDREL

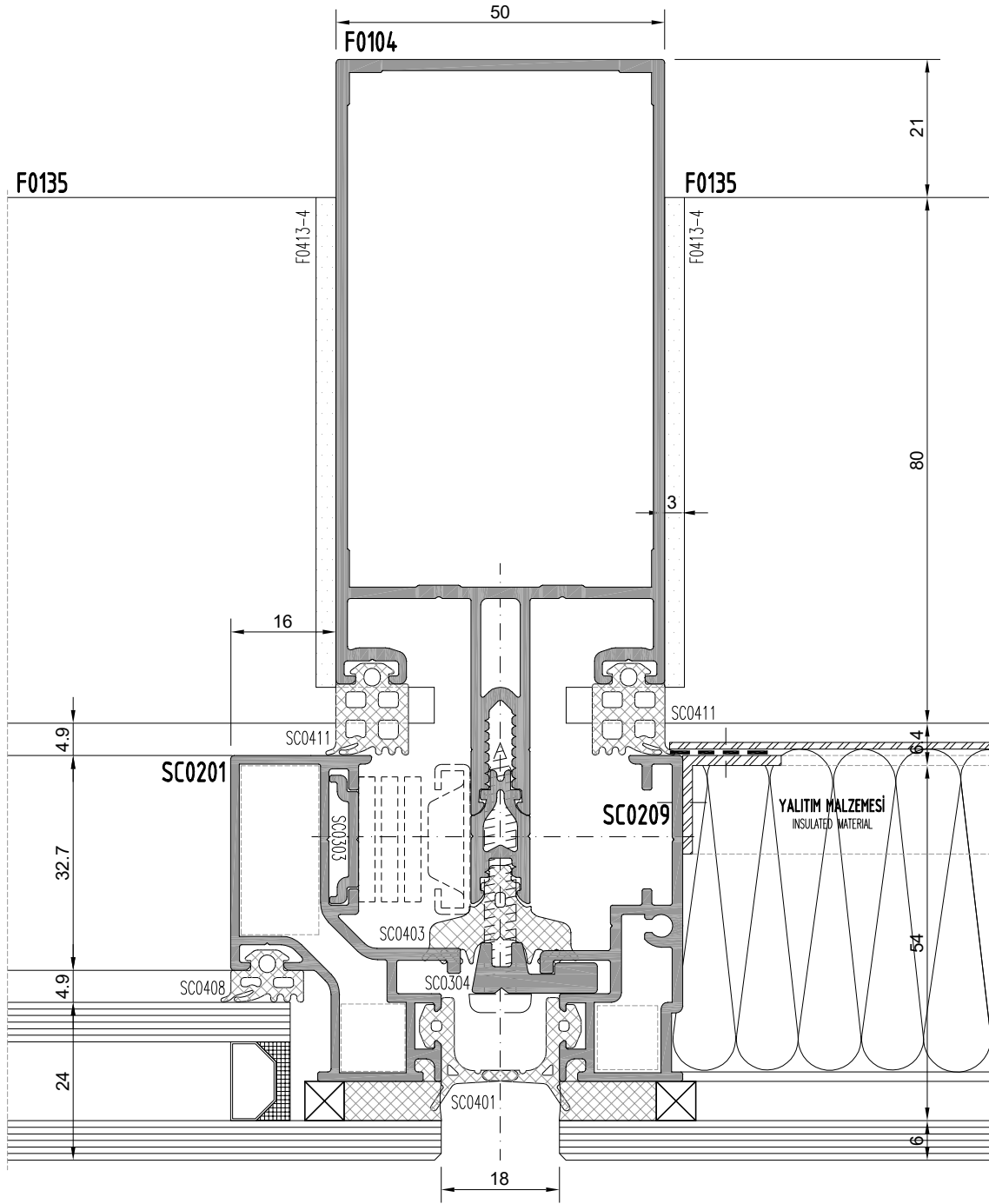
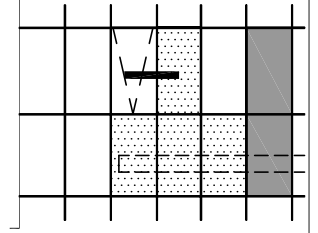

F50 KONDENS SİSTEM
SİLİKON CEPHE
F50 CONDENSAT SYSTEM
SILICONE FACADE

SPANDREL - SABİT
SPANDREL-FIXED

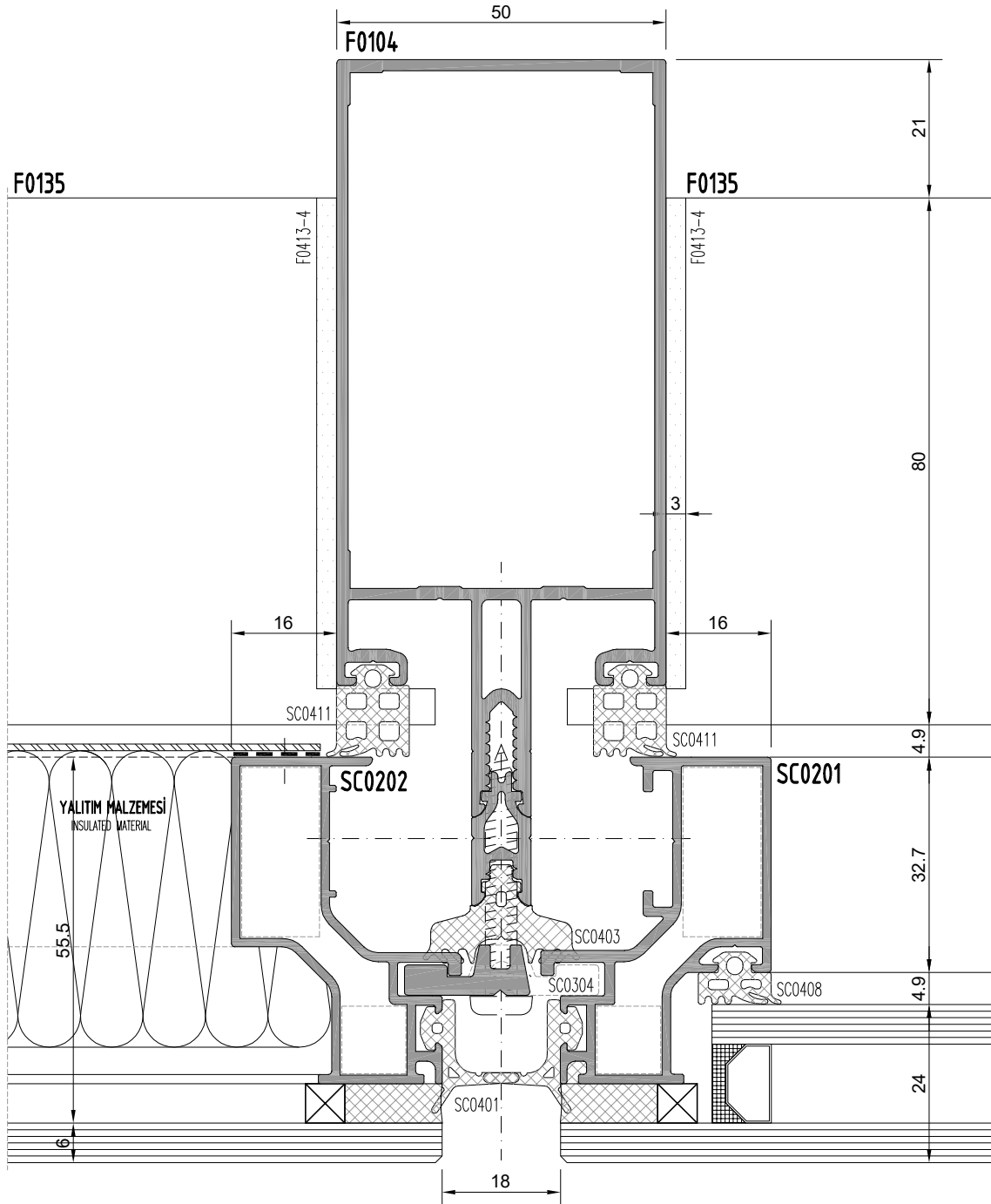
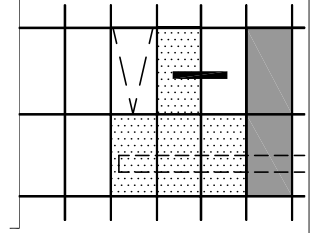

F50 KONDENS SİSTEM
SİLİKON CEPHE
F50 CONDENSAT SYSTEM
SILICONE FACADE

SABİT - KOMPOZİT
FIXED-COMPOSITE

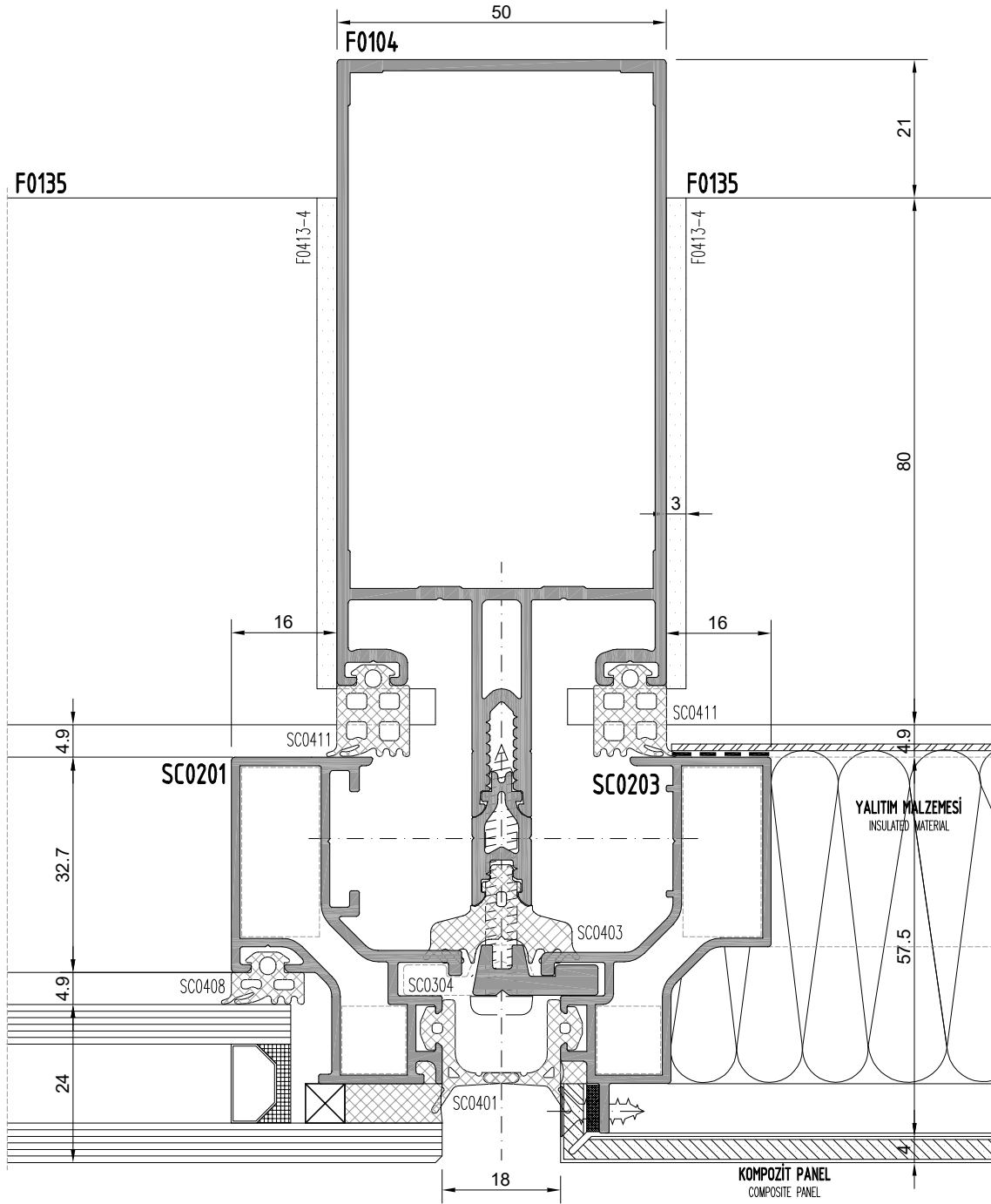
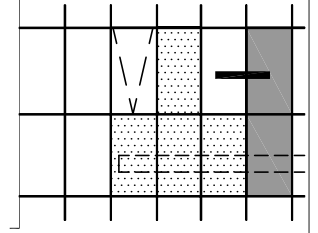

F50 KONDENS SİSTEM
SİLİKON CEPHE
F50 CONDENSAT SYSTEM
SILICONE FACADE

SABIT - KANAT
FIXED-SASH

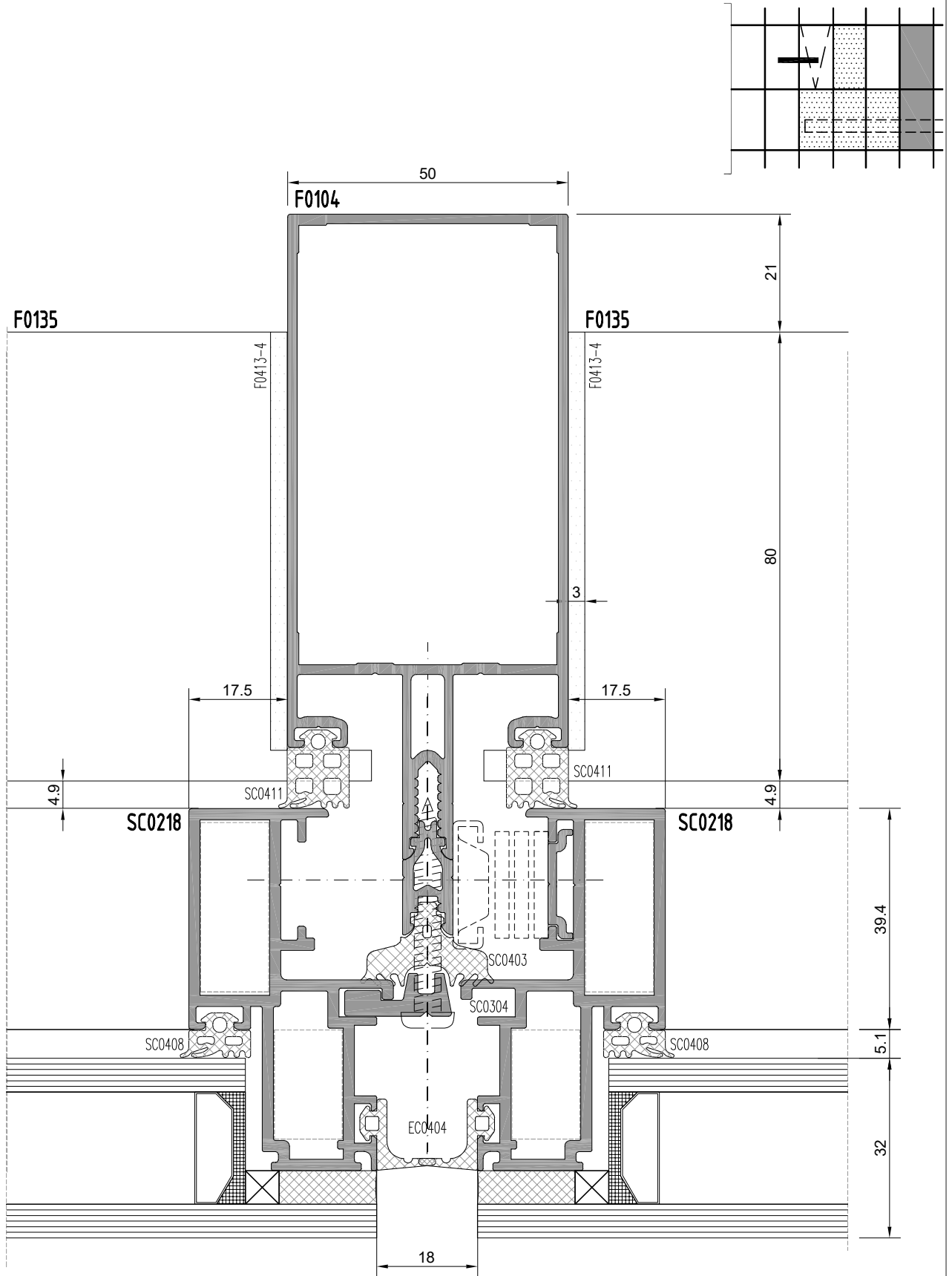

F50 KONDENS SİSTEM
SİLİKON CEPHE
F50 CONDENSAT SYSTEM
SILICONE FACADE

SABIT - KANAT
FIXED-SASH

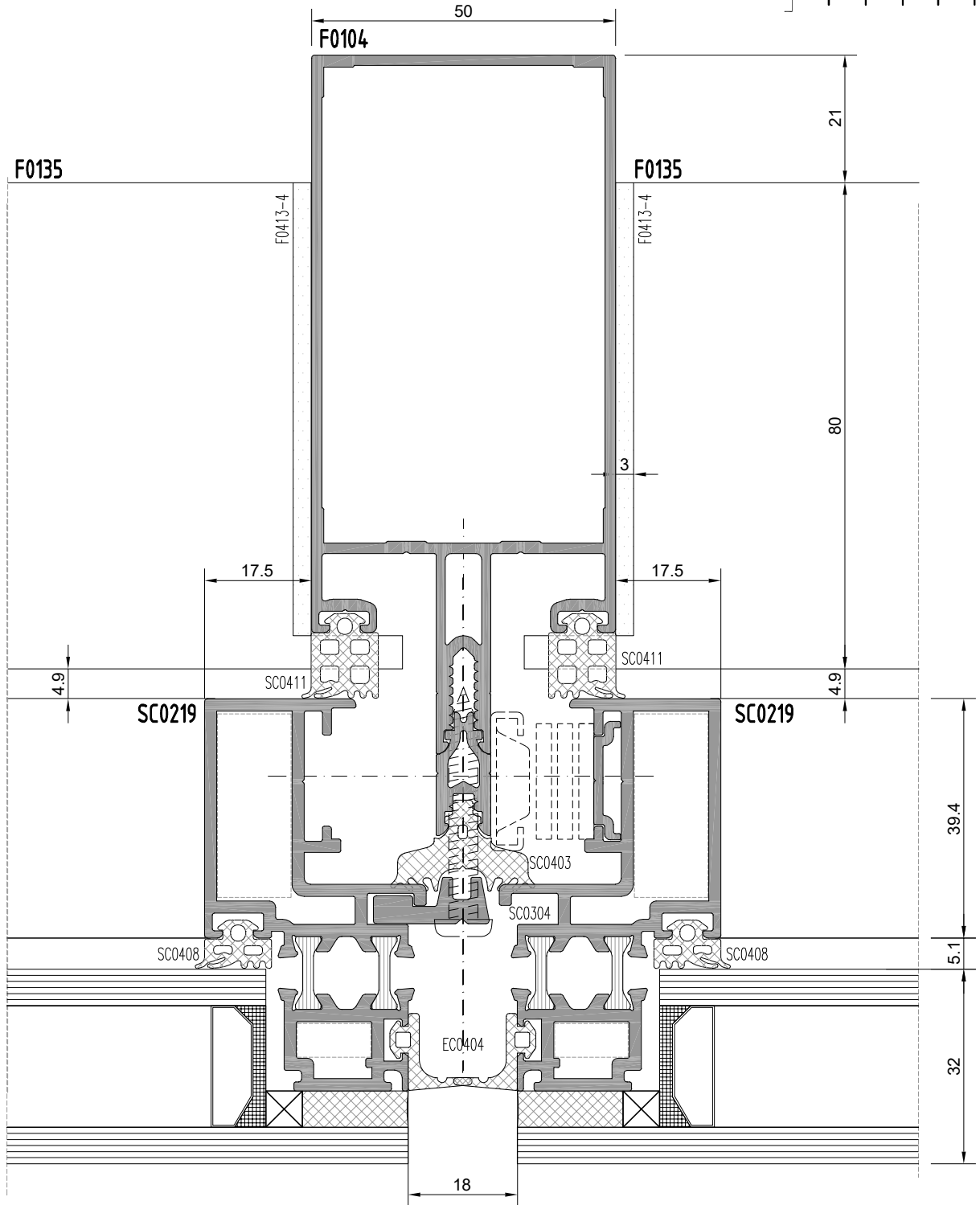
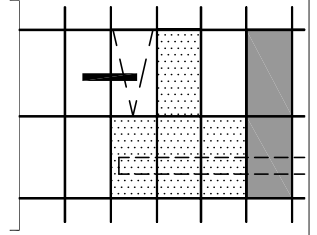

F50 KONDENS SİSTEM
SİLİKON CEPHE
F50 CONDENSAT SYSTEM
SILICONE FACADE

KANAT - SPANDREL
SASH-SPANDREL

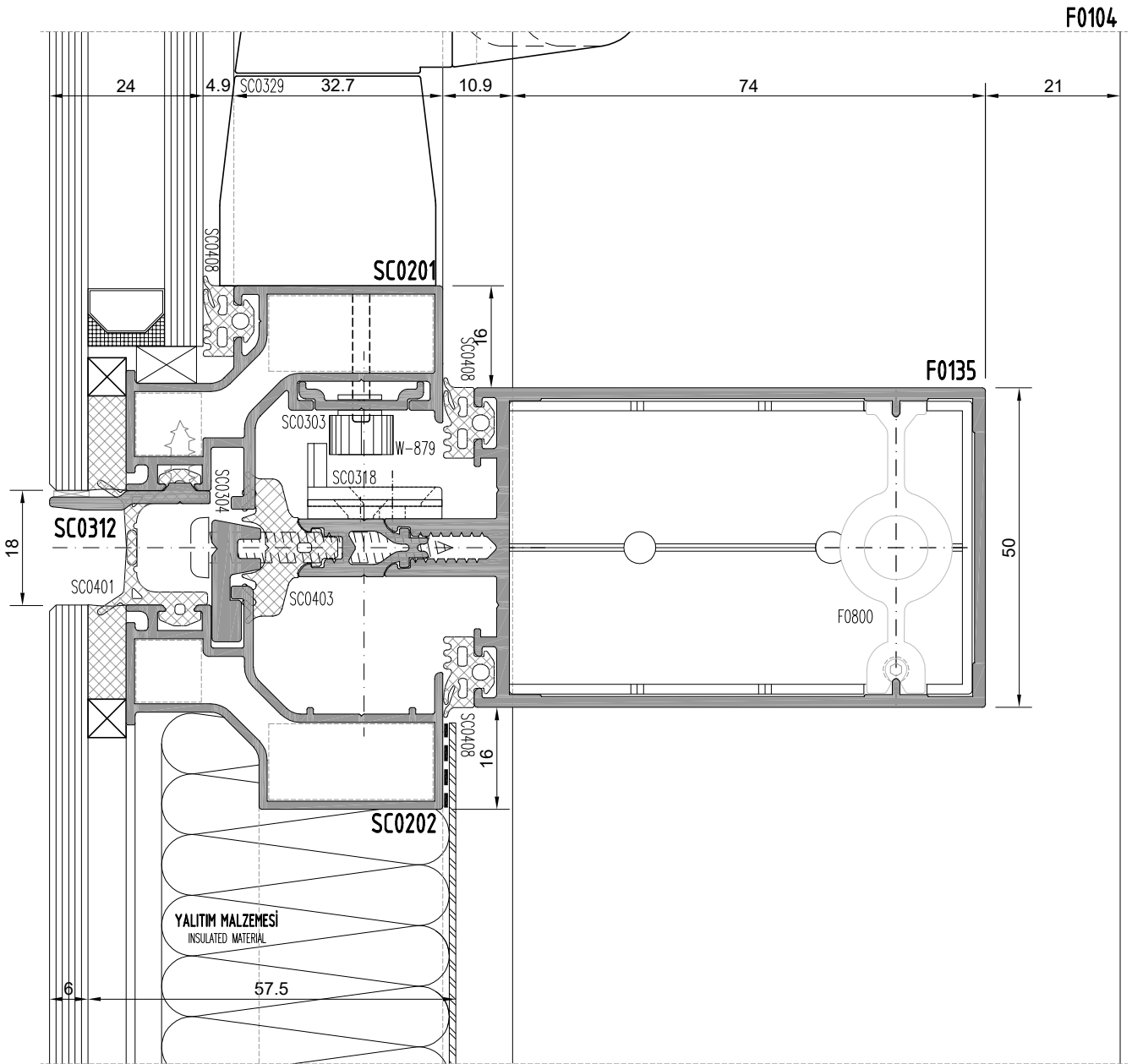
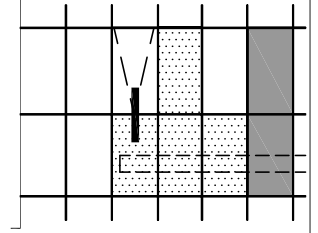

F50 KONDENS SİSTEM
SİLİKON CEPHE
F50 CONDENSAT SYSTEM
SILICONE FACADE

SPANDREL - SPANDREL
SPANDREL-SPANDREL

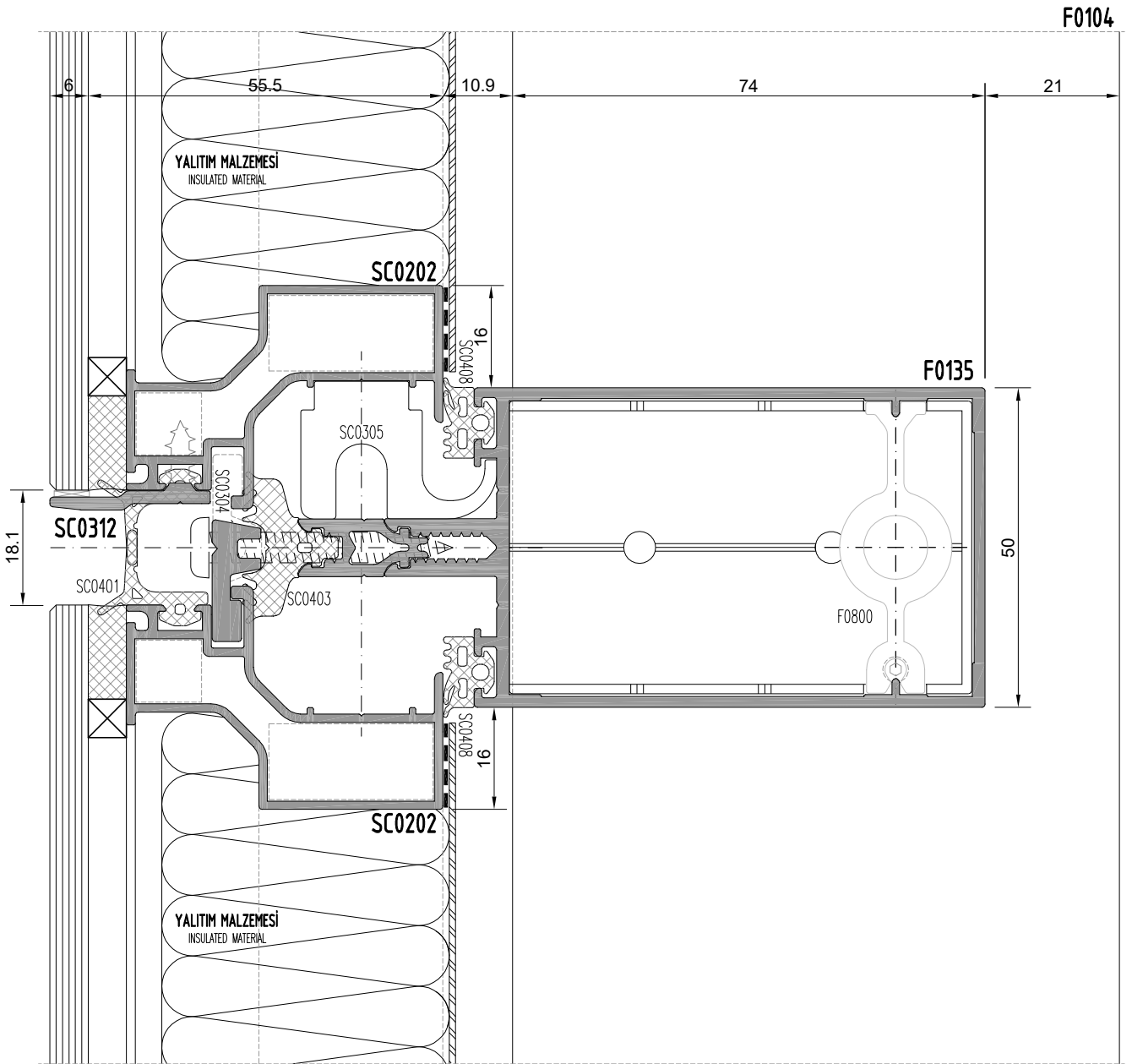
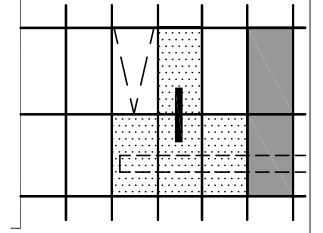

F50 KONDENS SİSTEM
SİLİKON CEPHE
F50 CONDENSAT SYSTEM
SILICONE FACADE

KOMPOZİT - KOMPOZİT
COMPOSITE-COMPOSITE

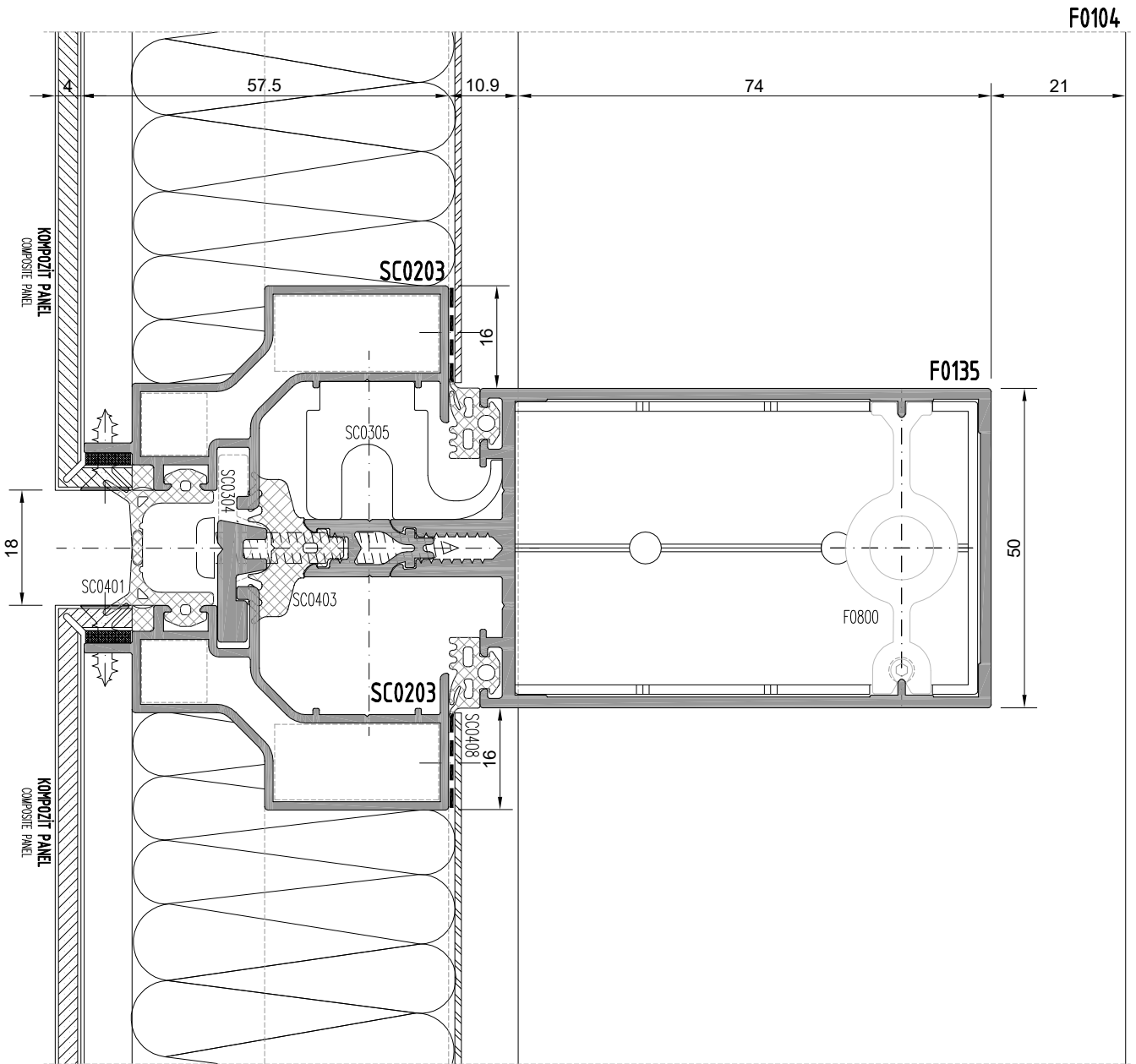
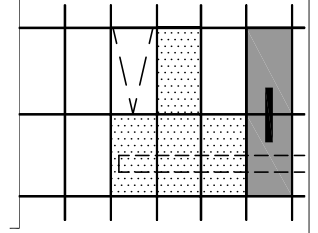

F50 KONDENS SİSTEM
SİLİKON CEPHE
F50 CONDENSAT SYSTEM
SILICONE FACADE

KANAT - SPANDREL
SASH-SPANDREL

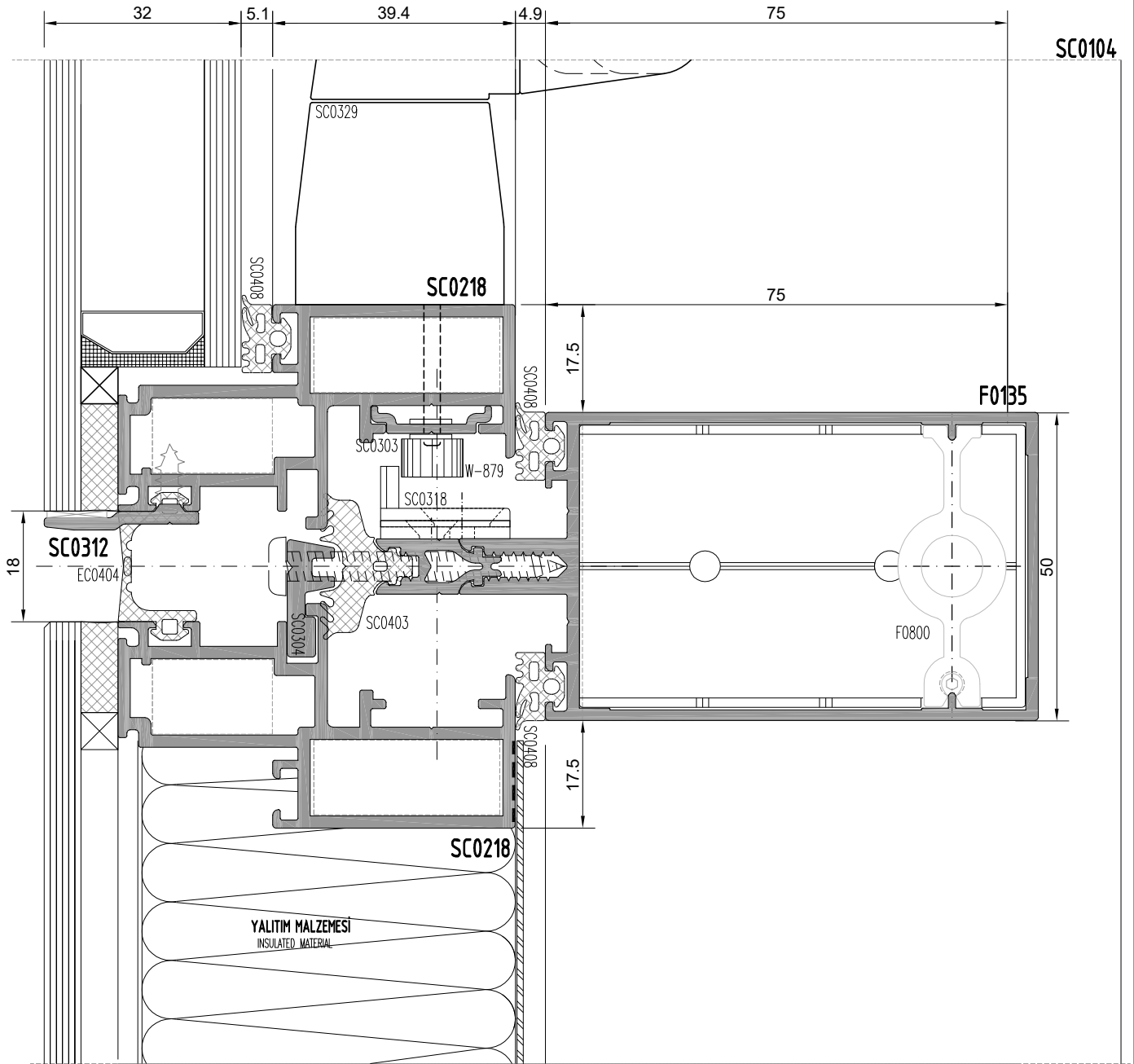
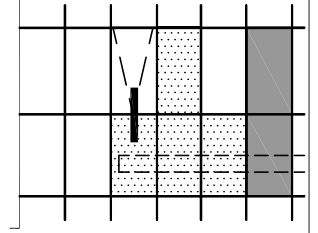

F50 KONDENS SİSTEM
SİLİKON CEPHE
F50 CONDENSAT SYSTEM
SILICONE FACADE

KANAT - SPANDREL
SASH-SPANDREL

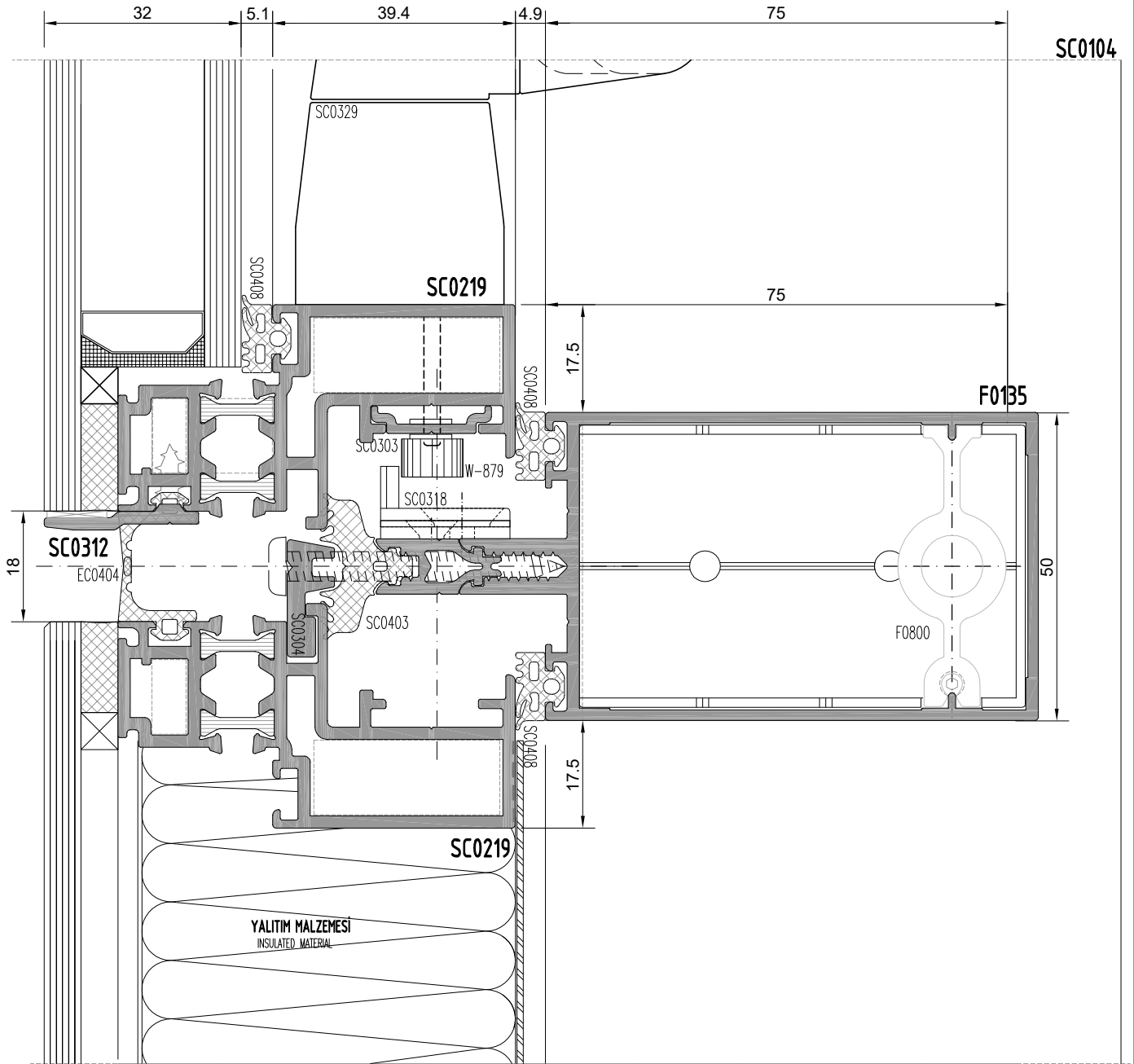
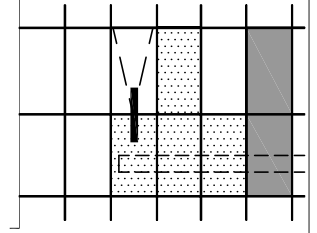

F50 KONDENS SİSTEM
SİLİKON CEPHE
F50 CONDENSAT SYSTEM
SILICONE FACADE

SABİT - KOMPOZİT
FIXED-COMPOSITE

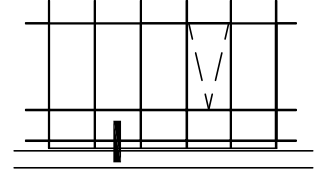

F0104

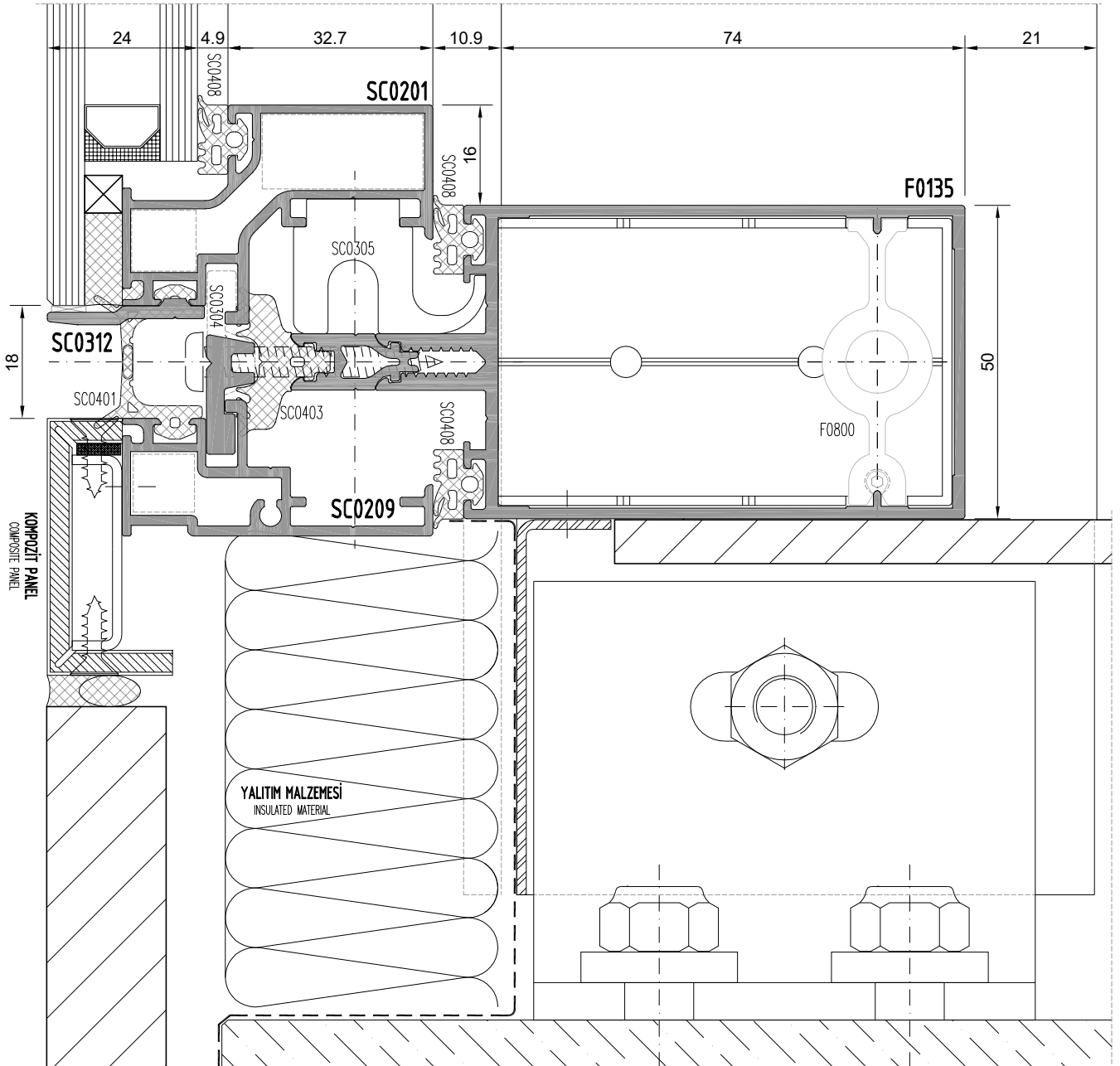

F50 KONDENS SİSTEM
SİLİKON CEPHE
F50 CONDENSAT SYSTEM
SILICONE FACADE

YAN BİTİM - SABİT
WALL CONNECTION-FIXED

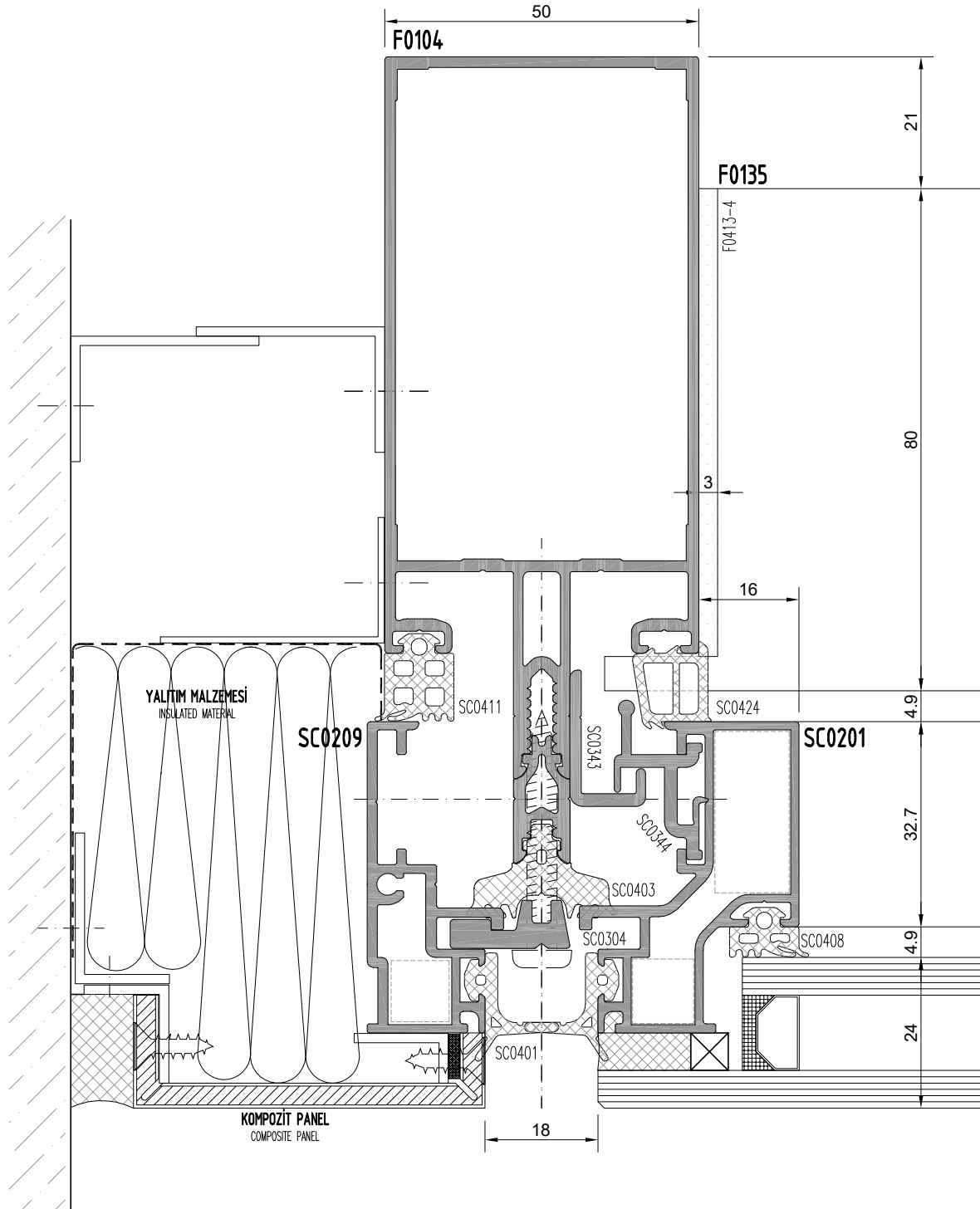
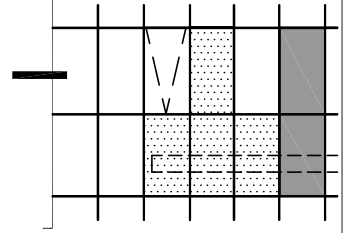

F50 KONDENS SİSTEM
SİLİKON CEPHE
F50 CONDENSAT SYSTEM
SILICONE FACADE

SABİT - SABİT
FIXED-FIXED

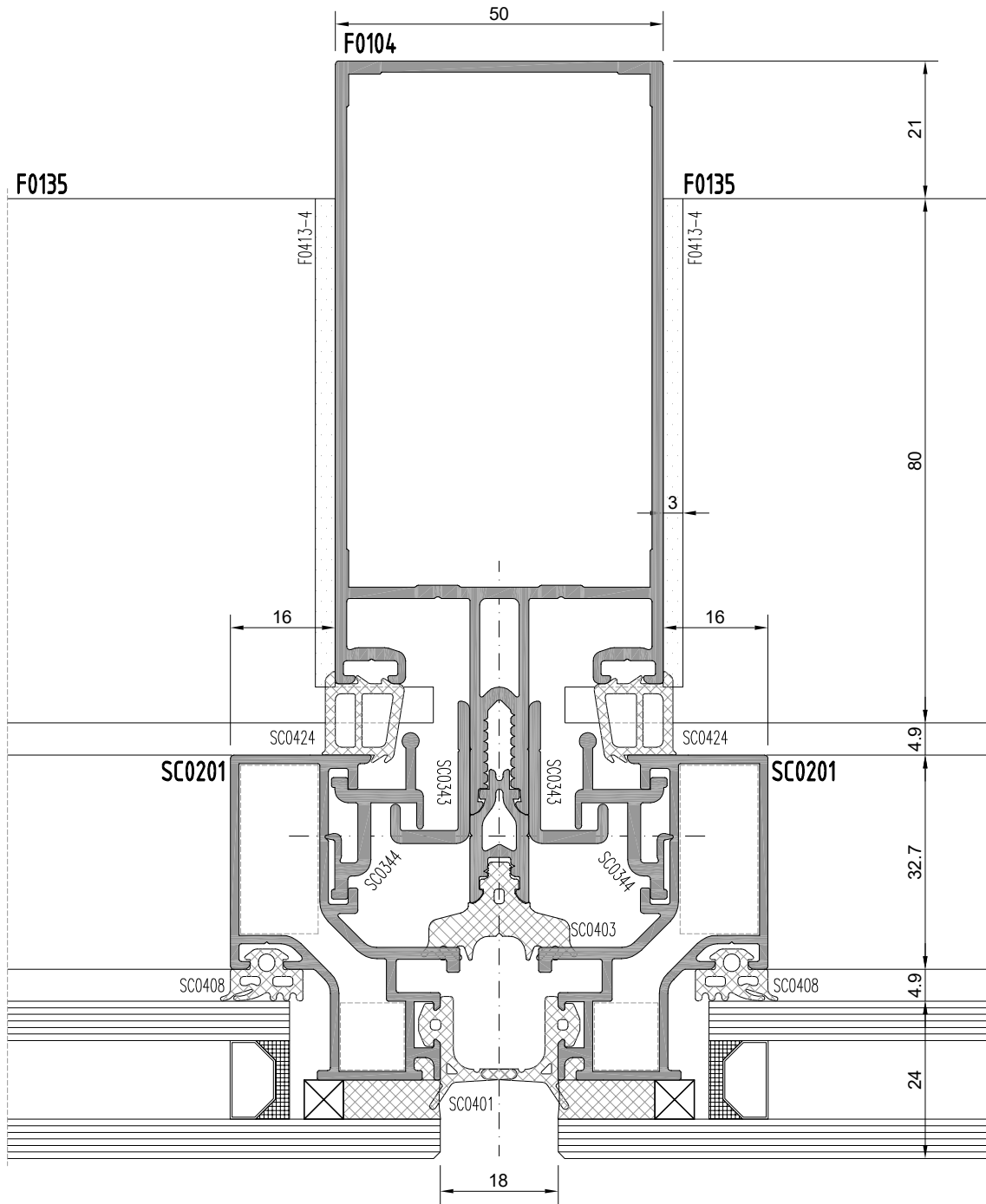
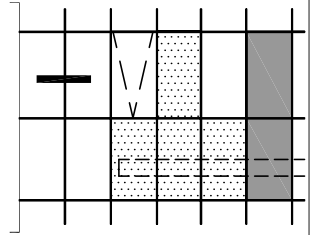

F50 KONDENS SİSTEM
SİLİKON CEPHE
F50 CONDENSAT SYSTEM
SILICONE FACADE

SABİT - KANAT
FIXED-SASH

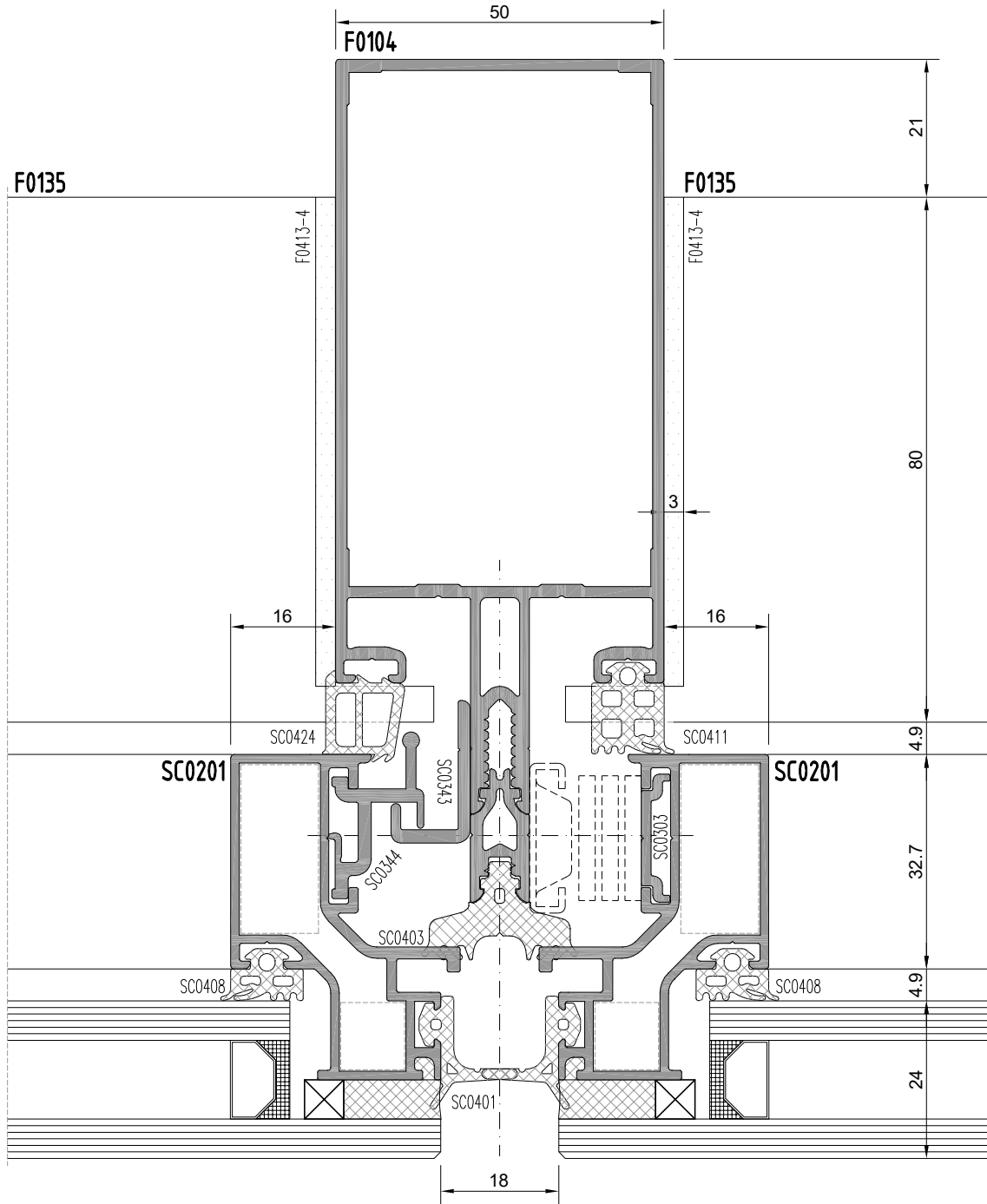
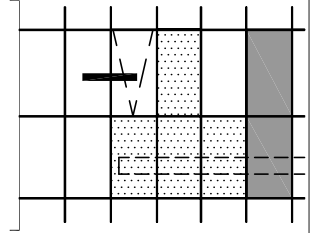

F50 KONDENS SİSTEM
SİLİKON CEPHE
F50 CONDENSAT SYSTEM
SILICONE FACADE

SABİT - KOMPOZİT
FIXED-COMPOSITE

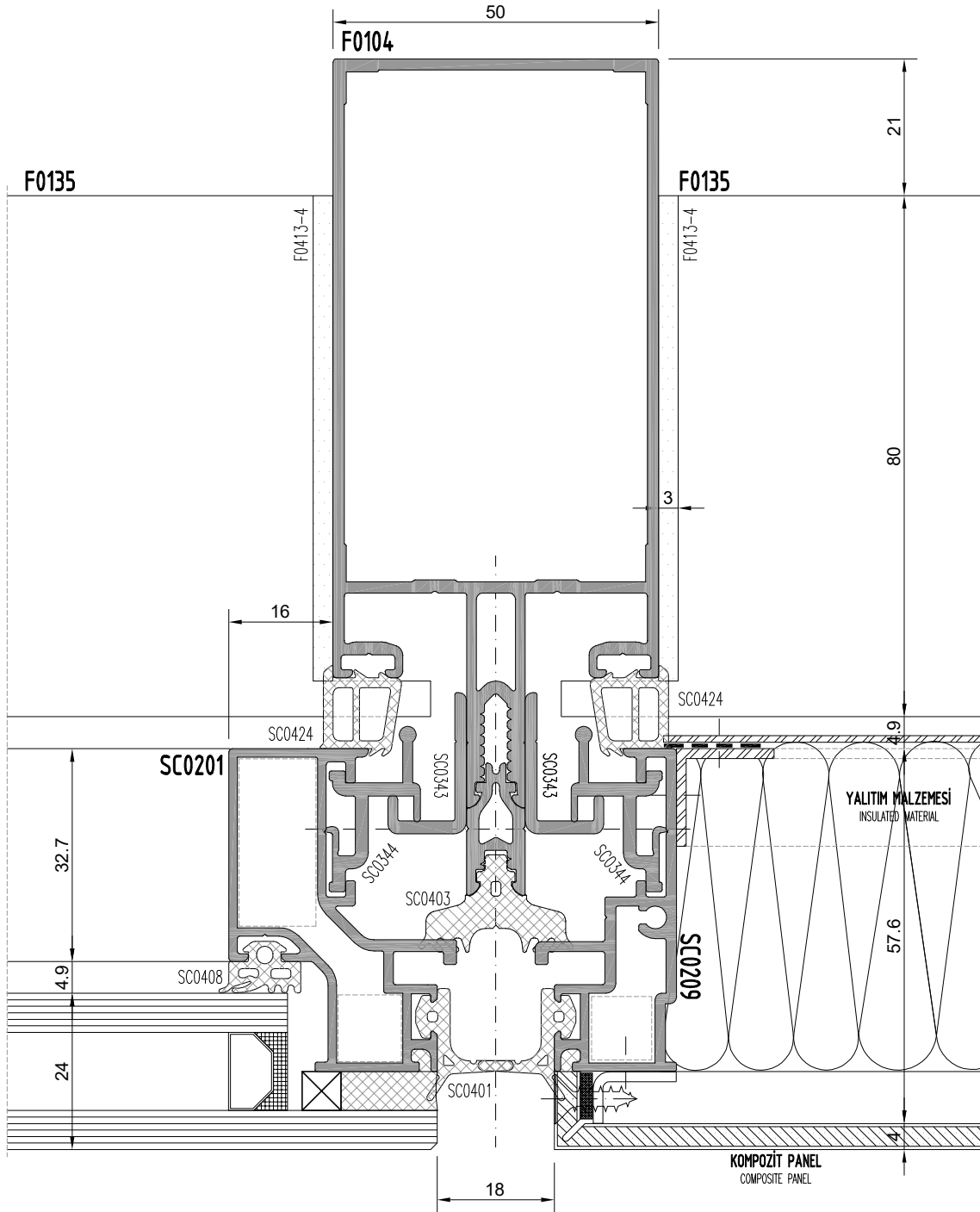
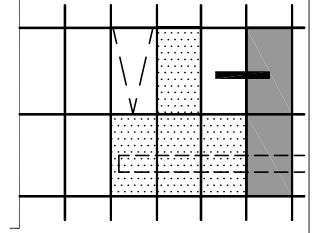

F50 KONDENS SİSTEM
SİLİKON CEPHE
F50 CONDENSAT SYSTEM
SILICONE FACADE

SABİT - SABİT
FIXED-FIXED

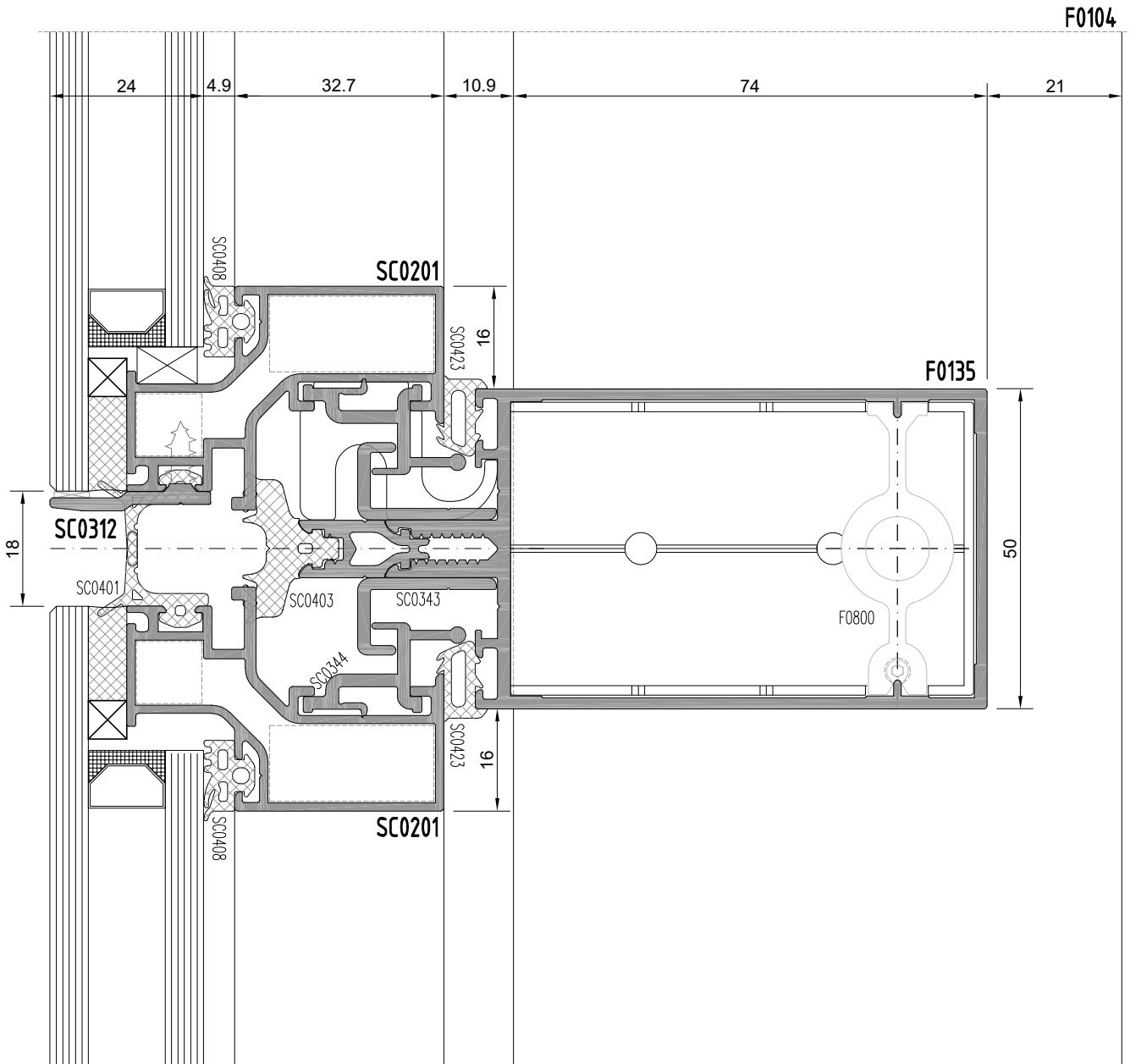
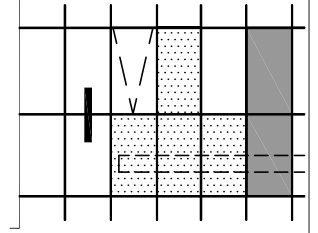

F50 KONDENS SİSTEM
SİLİKON CEPHE
F50 CONDENSAT SYSTEM
SILICONE FACADE

KANAT - SPANDREL
SASH-SPANDREL

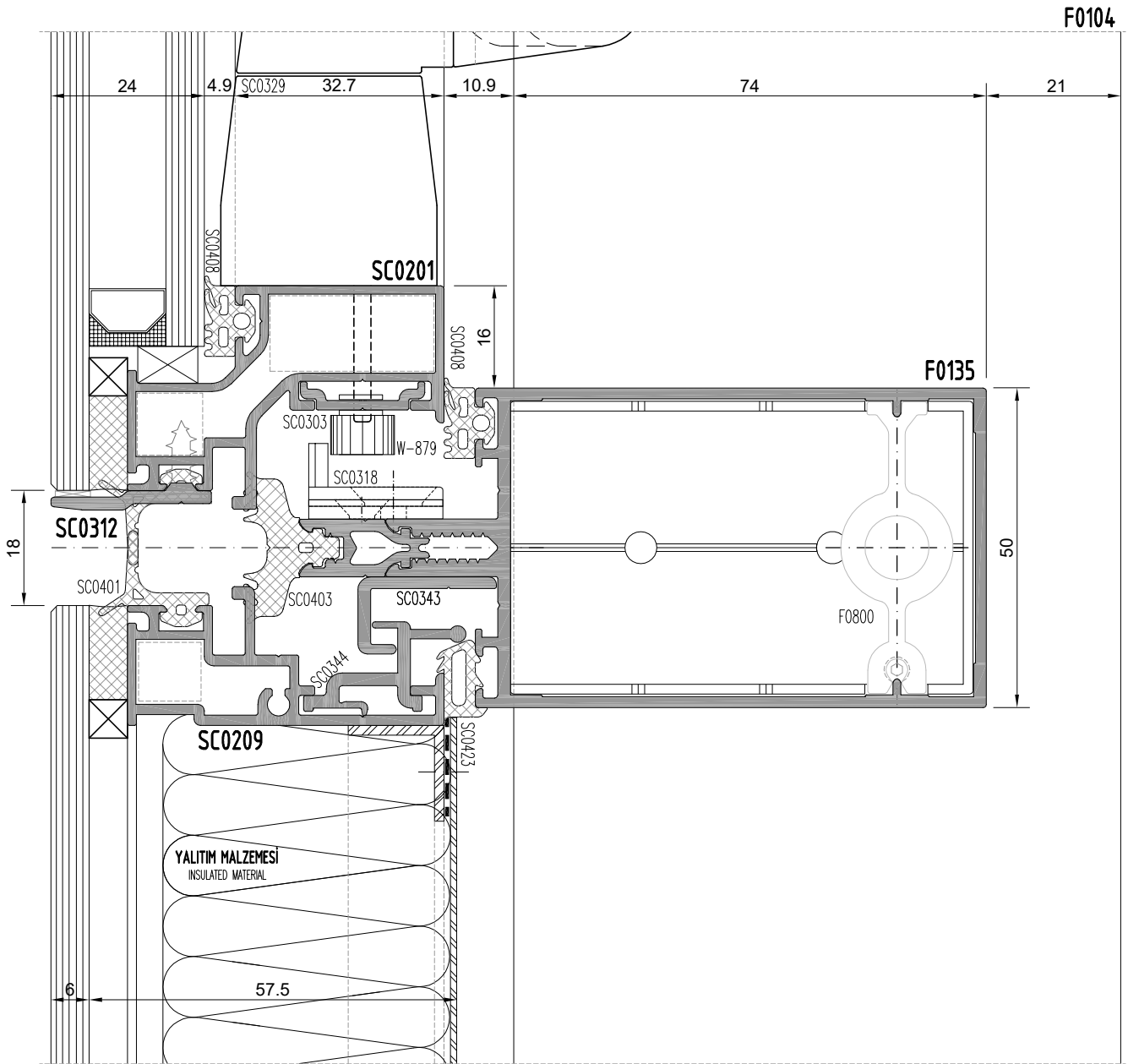
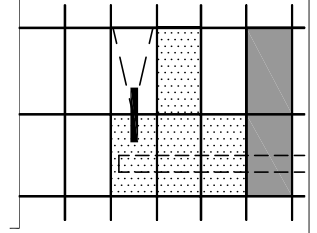

F50 KONDENS SİSTEM
SİLİKON CEPHE
F50 CONDENSAT SYSTEM
SILICONE FACADE

SABİT - SPANDREL
FIXED-SPANDREL

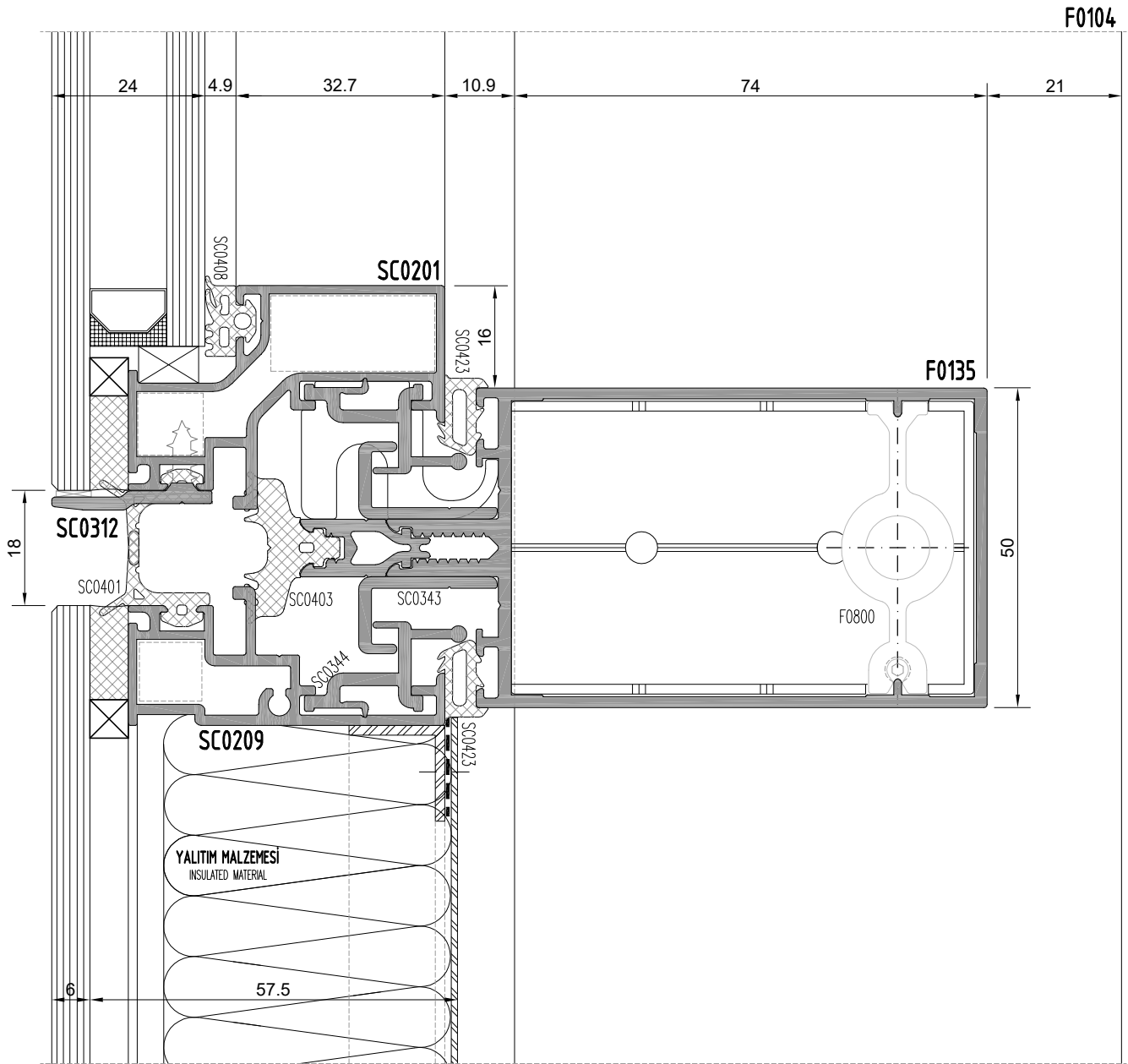
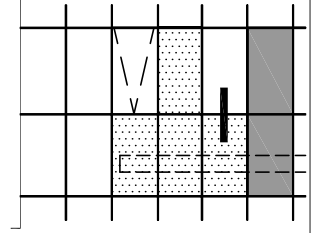

F50 KONDENS SİSTEM
SİLİKON CEPHE
F50 CONDENSAT SYSTEM
SILICONE FACADE

SABİT - KOMPOZİT
FIXED-COMPOSITE

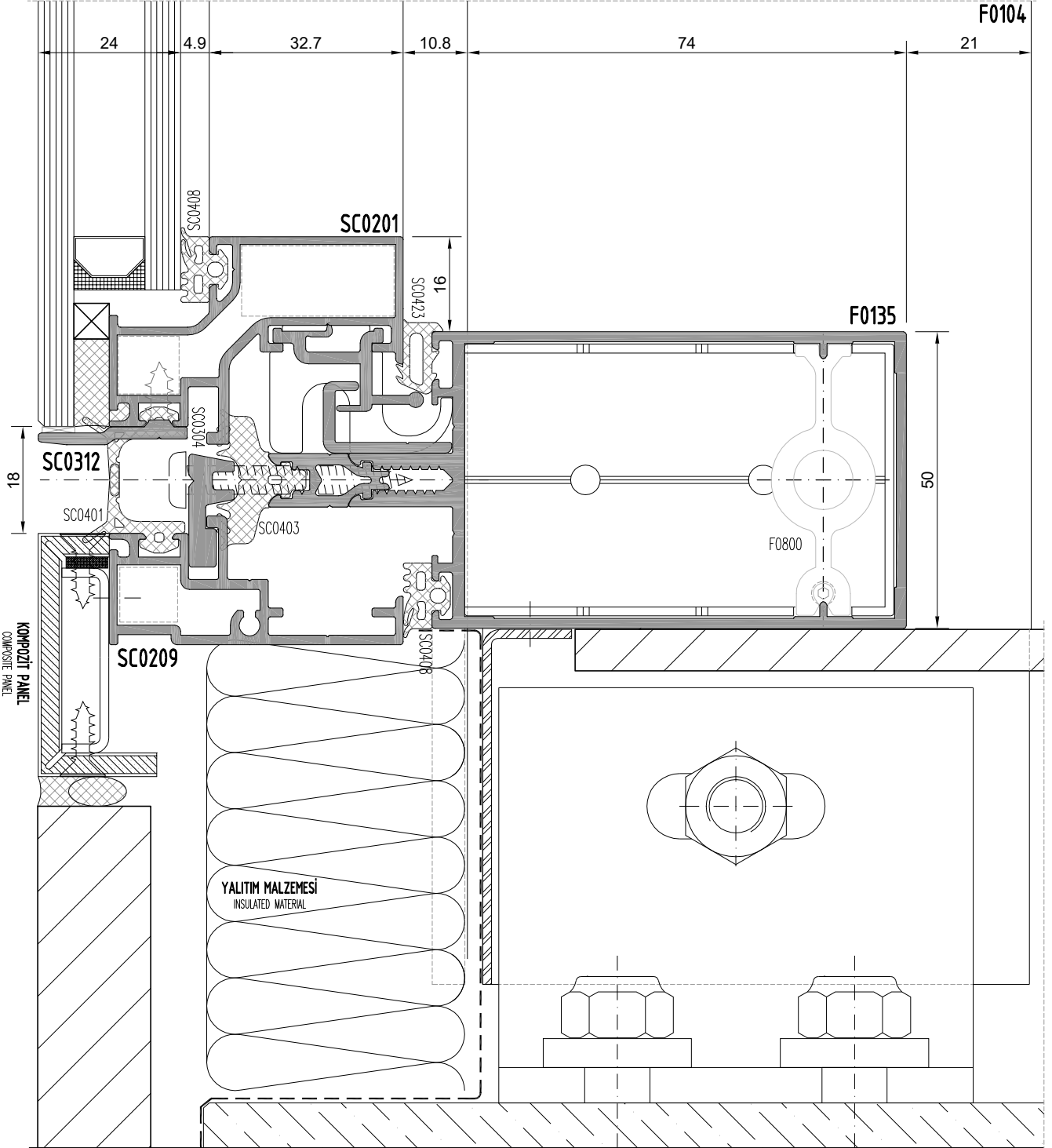
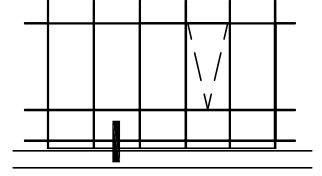

F50 KONDENS SİSTEM
SİLİKON CEPHE
F50 CONDENSAT SYSTEM
SILICONE FACADE

SABİT - SABİT
FIXED-FIXED

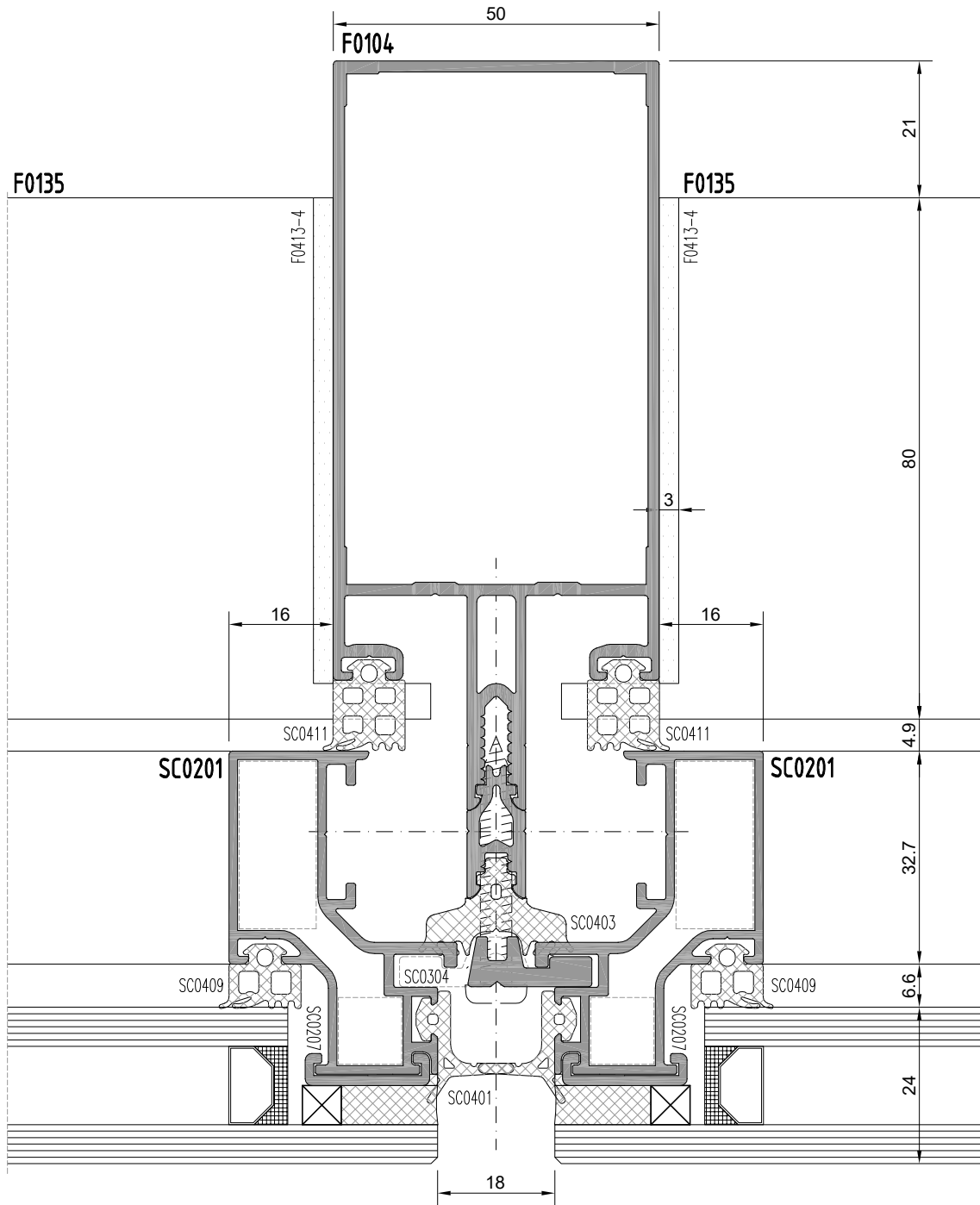
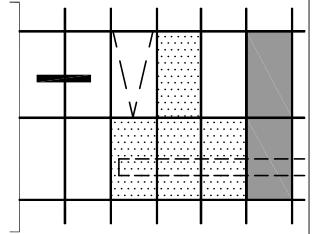

F50 KONDENS SİSTEM
SİLİKON CEPHE
F50 CONDENSAT SYSTEM
SILICONE FACADE

SABIT - KANAT
FIXED-SASH

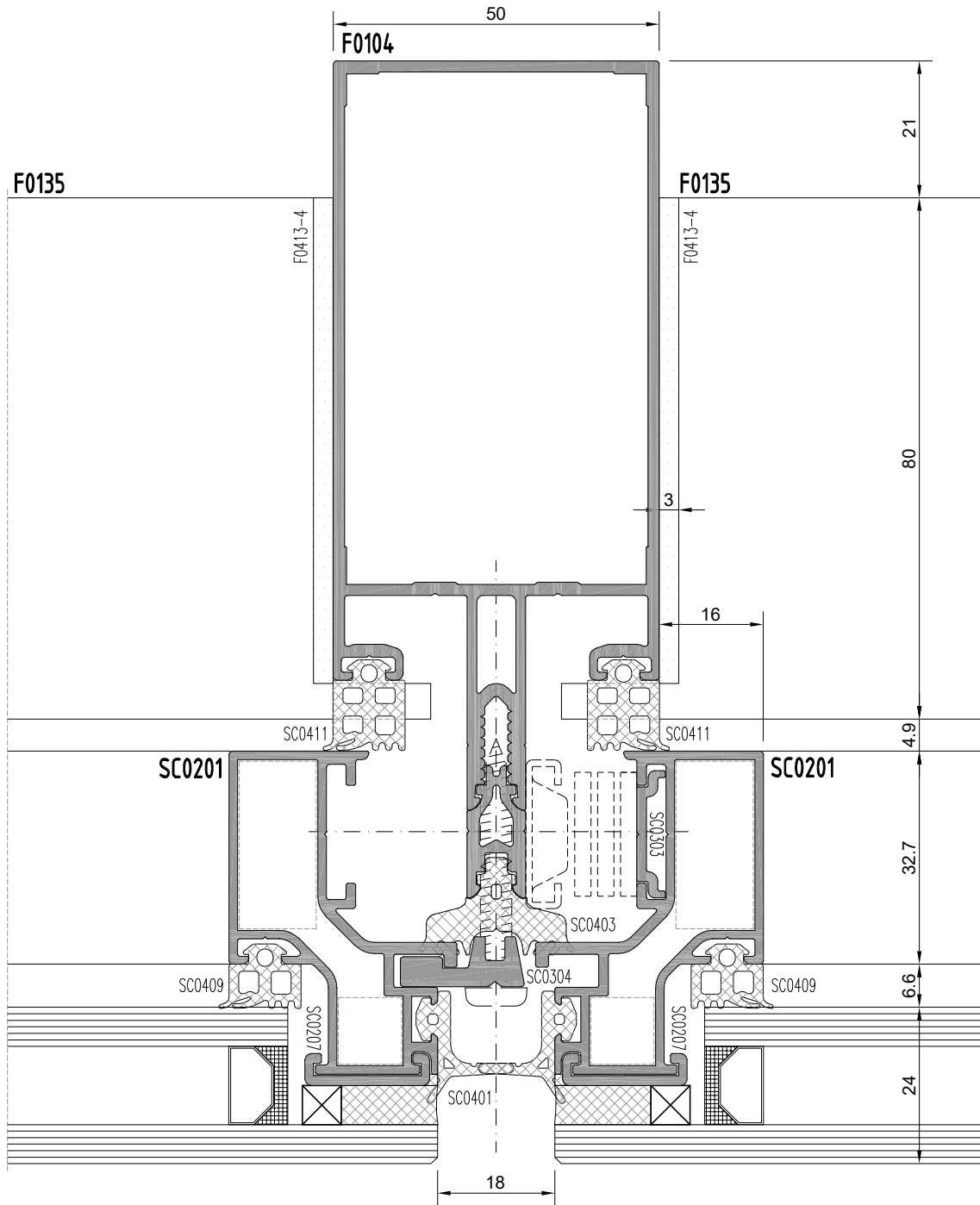
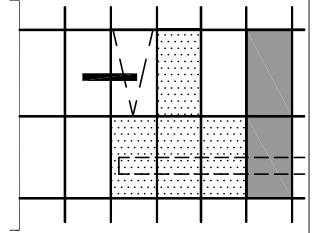

F50 KONDENS SİSTEM
SİLİKON CEPHE
F50 CONDENSAT SYSTEM
SILICONE FACADE

KANAT - SPANDREL
SASH-SPANDREL

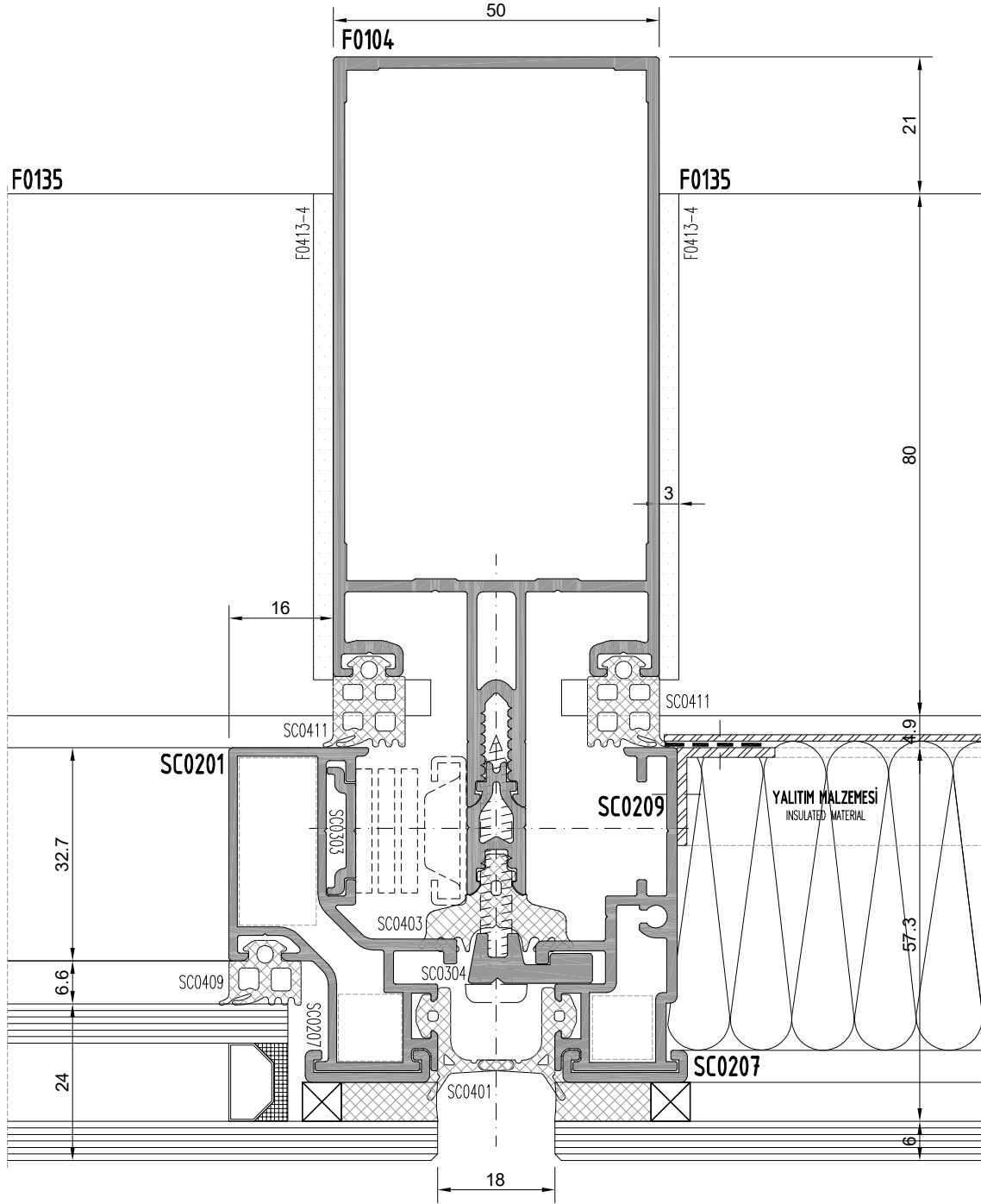
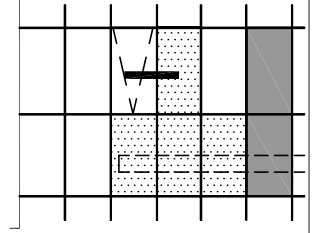

F50 KONDENS SİSTEM
SİLİKON CEPHE
F50 CONDENSAT SYSTEM
SILICONE FACADE

SPANDREL - SABİT
SPANDREL-FIXED

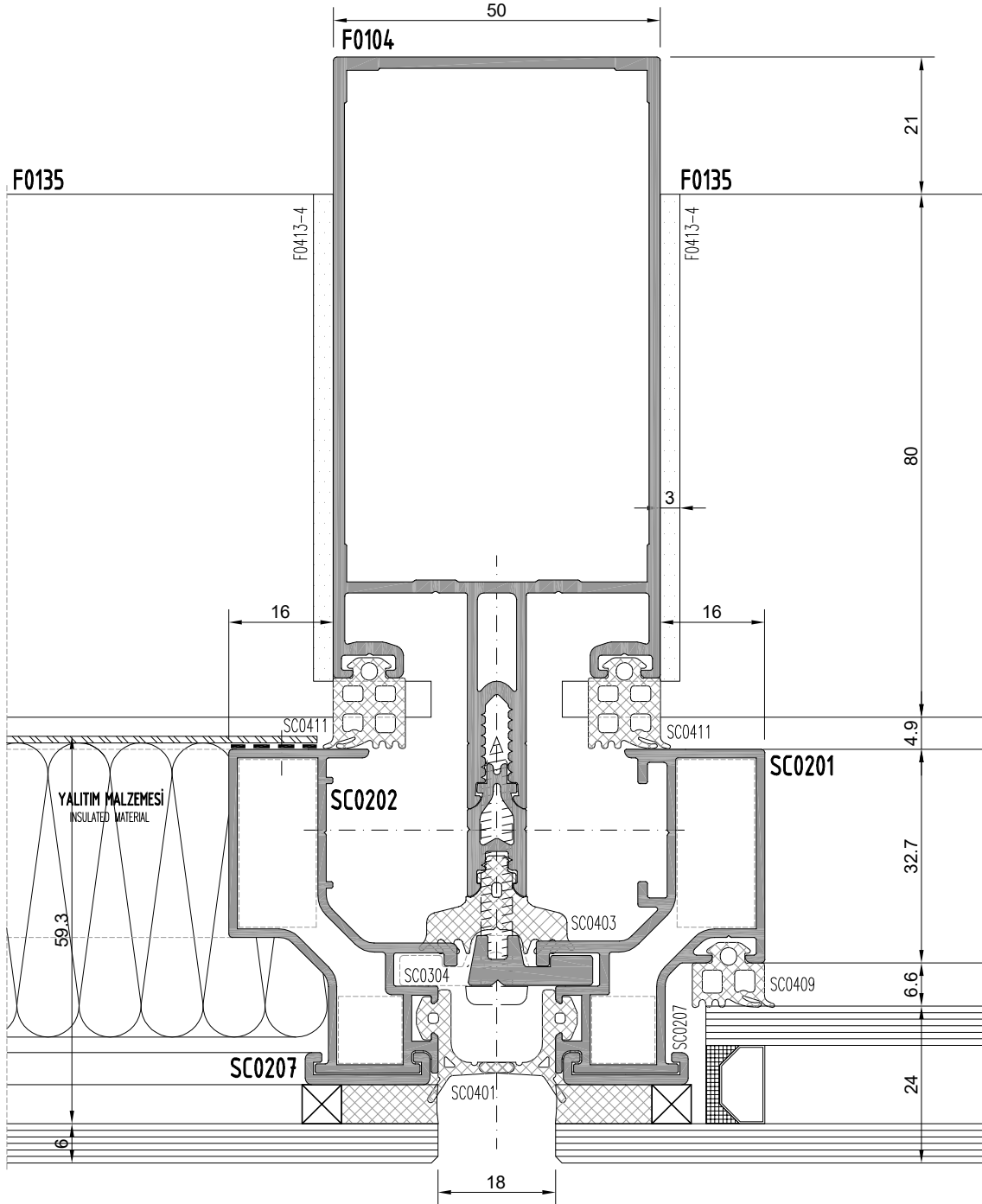
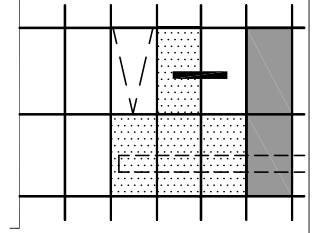

F50 KONDENS SİSTEM
SİLİKON CEPHE
F50 CONDENSAT SYSTEM
SILICONE FACADE

SABİT - KOMPOZİT
FIXED-COMPOSITE

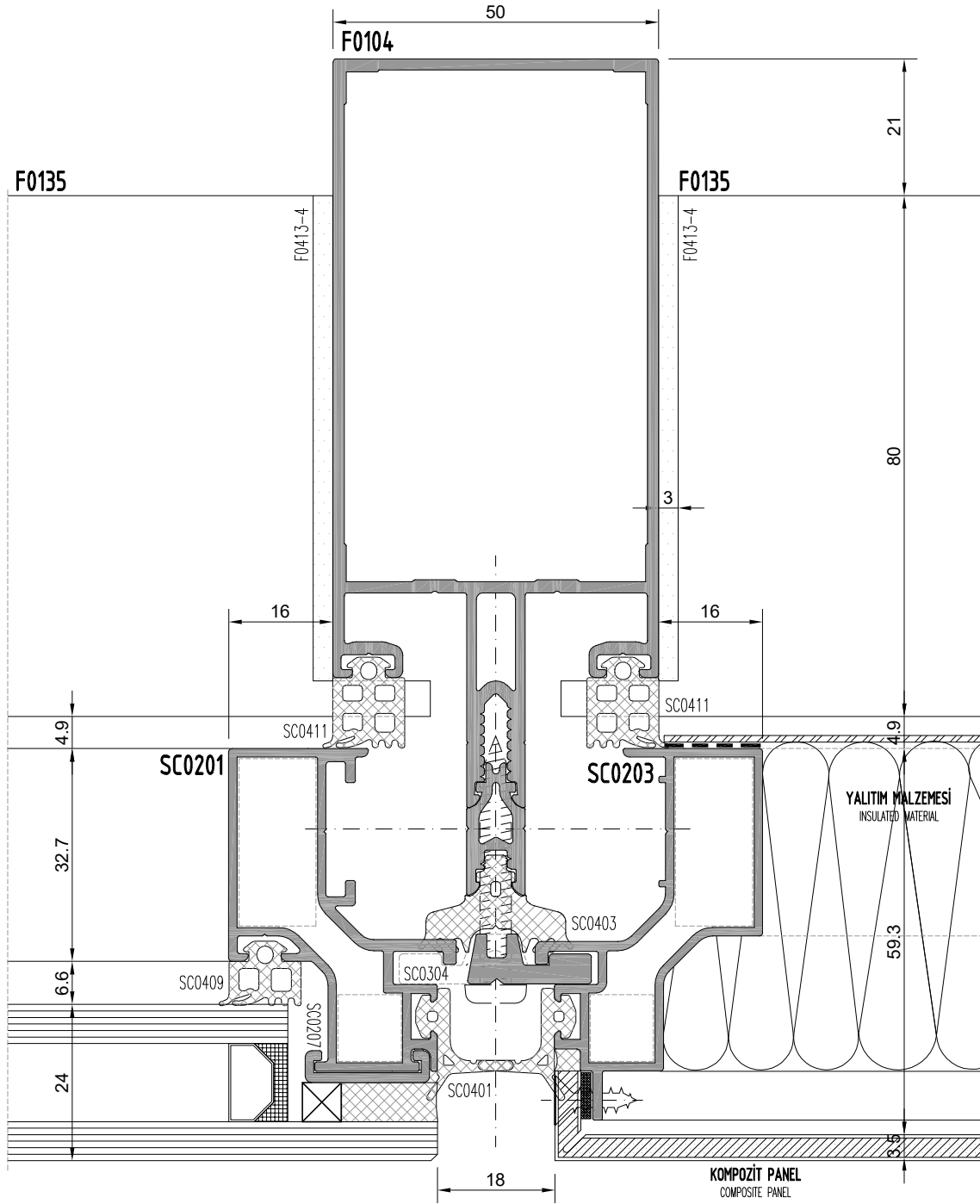
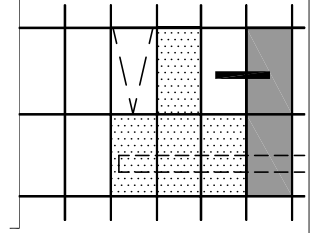

F50 KONDENS SİSTEM
SİLİKON CEPHE
F50 CONDENSAT SYSTEM
SILICONE FACADE

SABIT - KANAT
FIXED-SASH

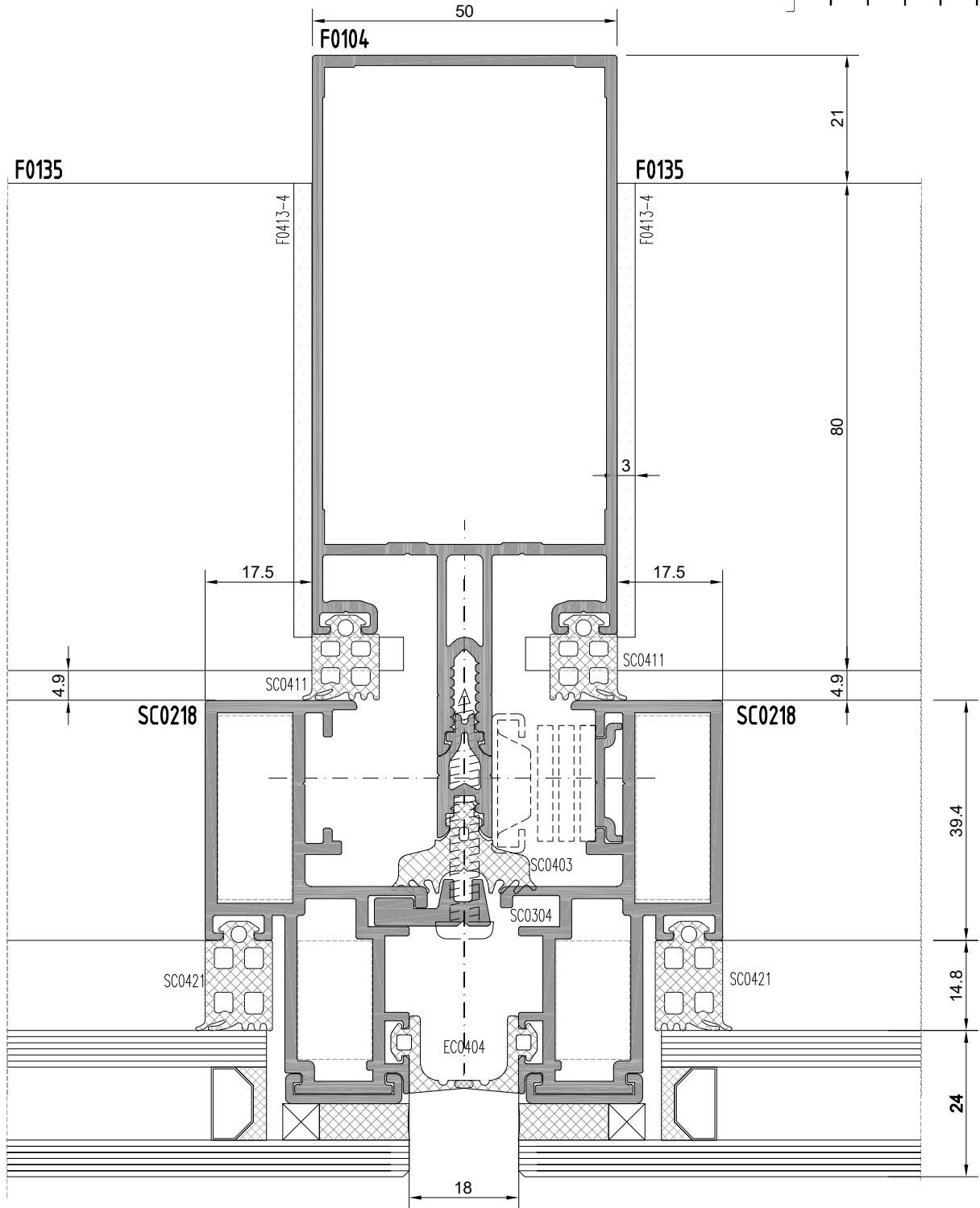
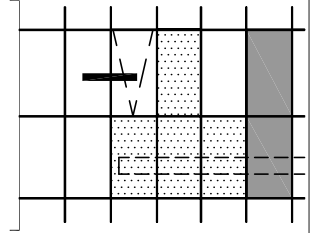

F50 KONDENS SİSTEM
SİLİKON CEPHE
F50 CONDENSAT SYSTEM
SILICONE FACADE

SABİT - SABİT
FIXED-FIXED

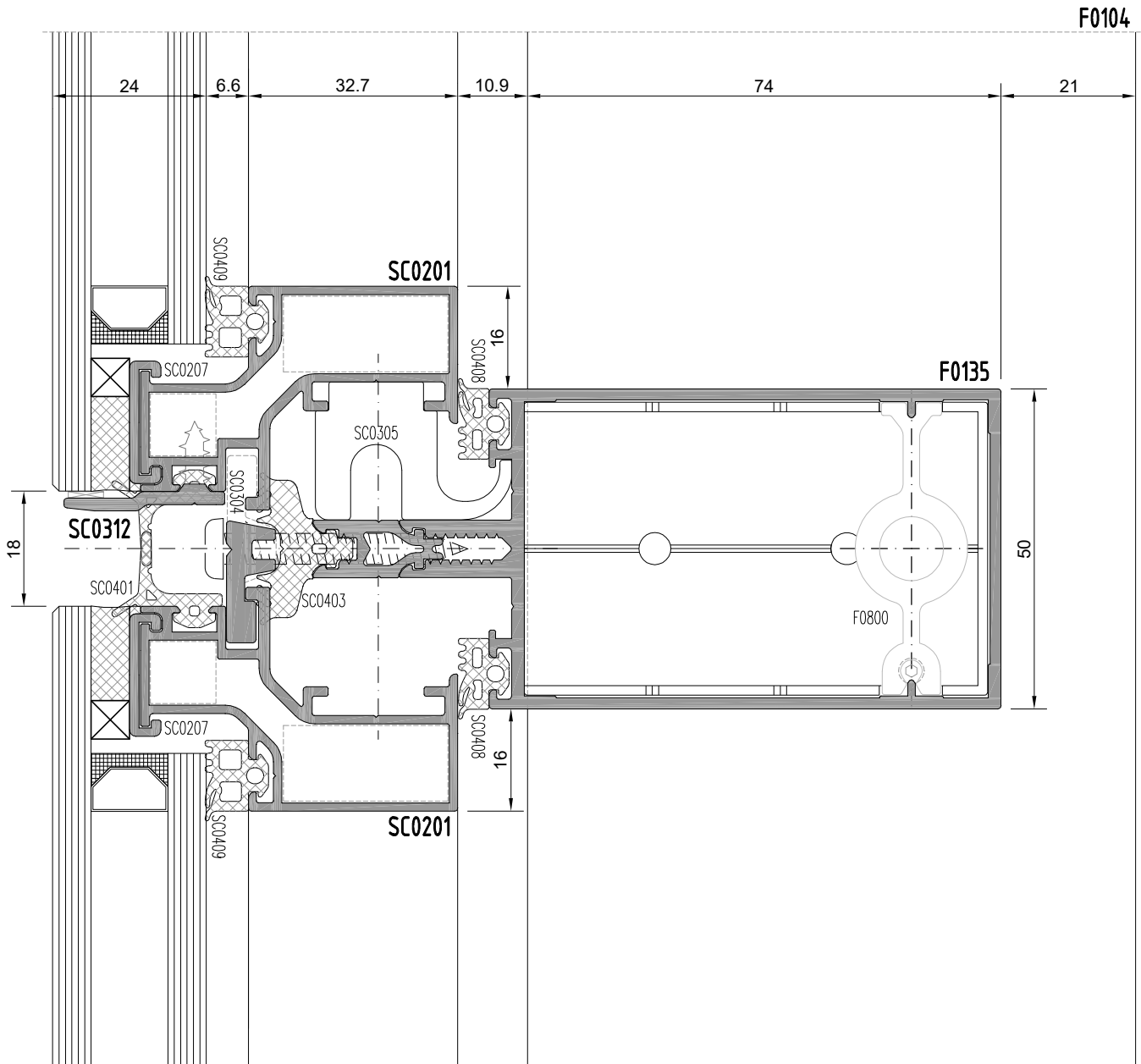
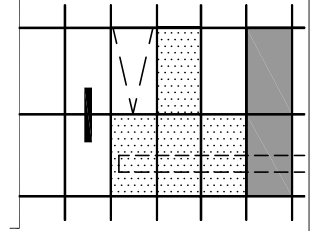

F50 KONDENS SİSTEM
SİLİKON CEPHE
F50 CONDENSAT SYSTEM
SILICONE FACADE

KANAT - SPANDREL
SASH-SPANDREL

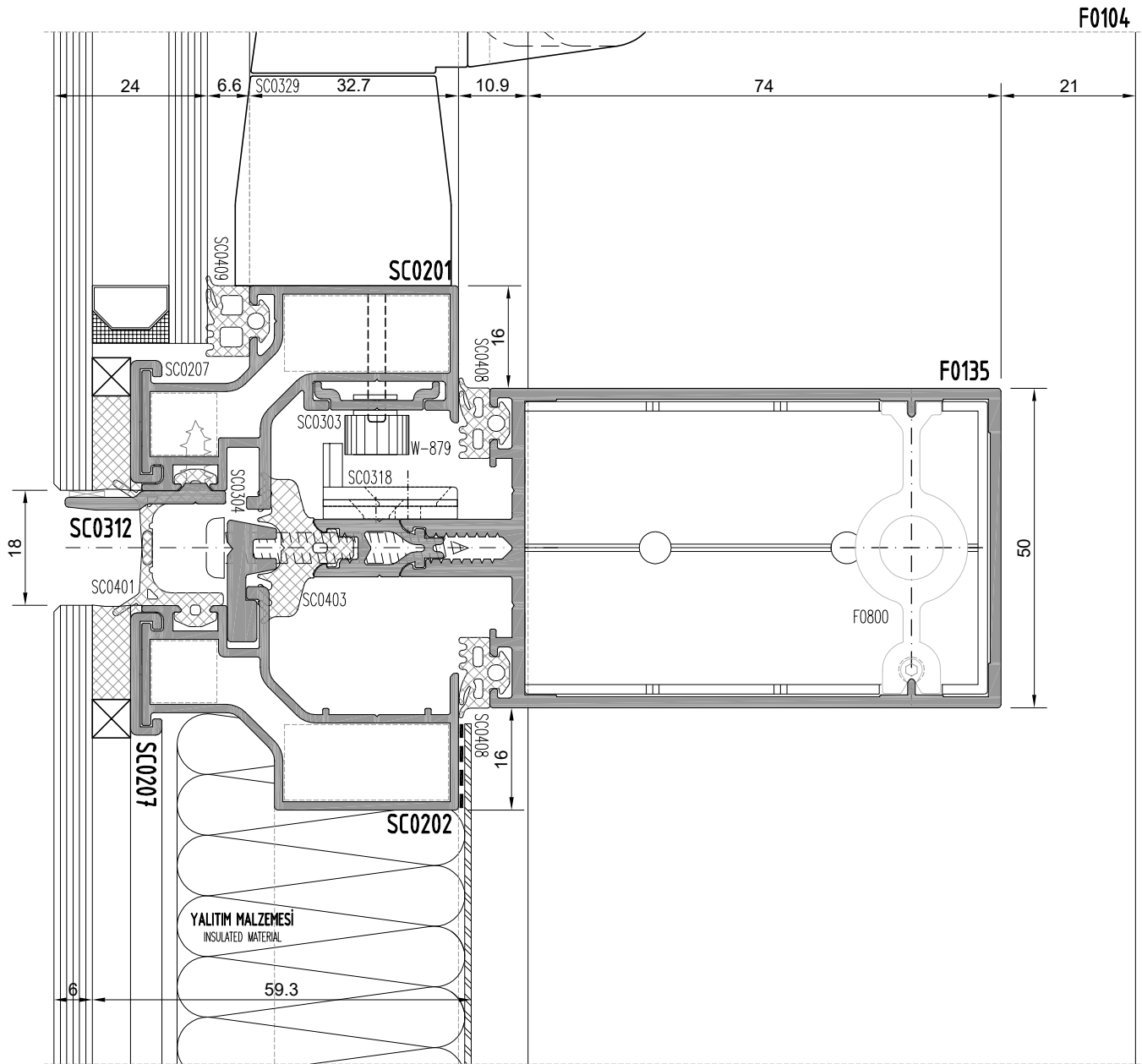
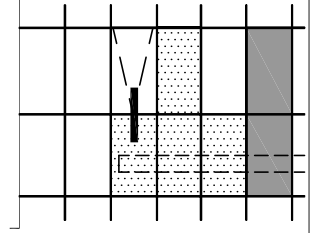

F50 KONDENS SİSTEM
SİLİKON CEPHE
F50 CONDENSAT SYSTEM
SILICONE FACADE

SABİT - SPANDREL
FIXED-SPANDREL

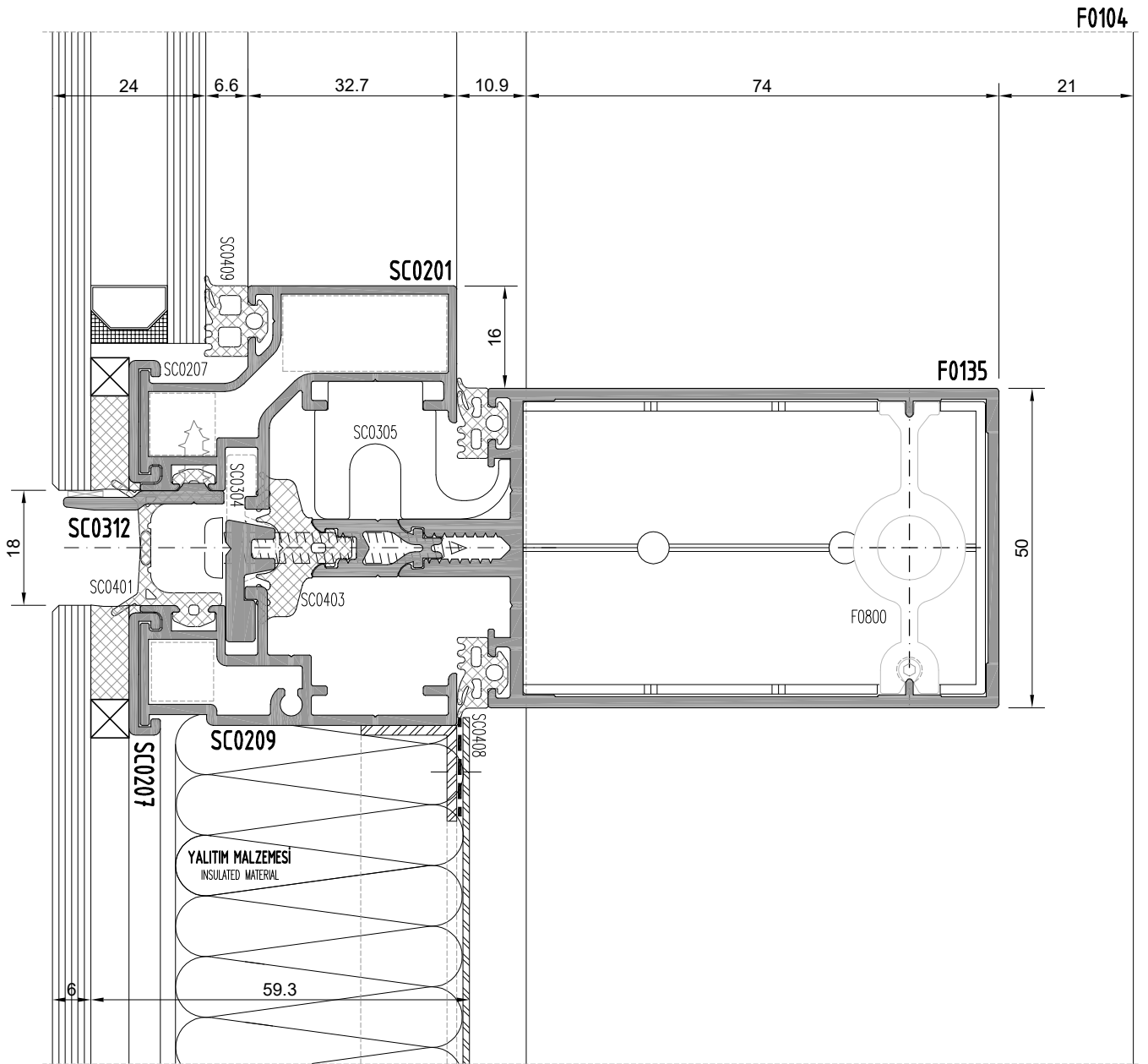
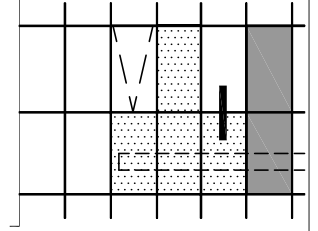

F50 KONDENS SİSTEM
SİLİKON CEPHE
F50 CONDENSAT SYSTEM
SILICONE FACADE

SABİT - SABİT
FIXED-FIXED

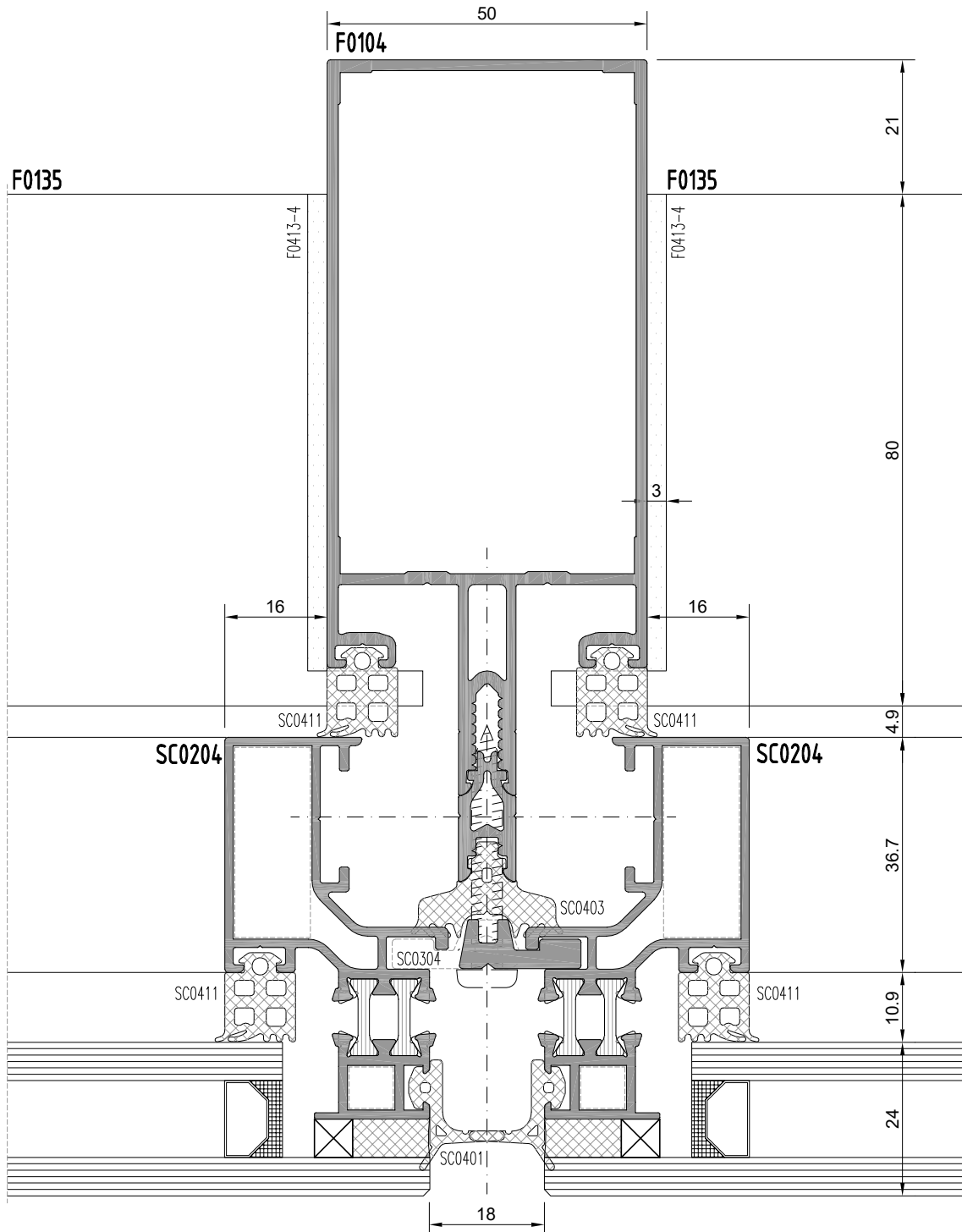
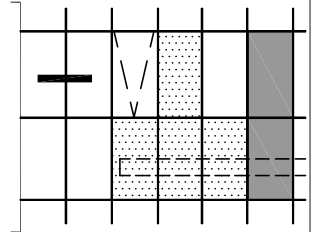

F50 KONDENS SİSTEM

SİLİKON CEPHE

F50 CONDENSAT SYSTEM
SILICONE FACADE

SABIT - KANAT
FIXED-SASH

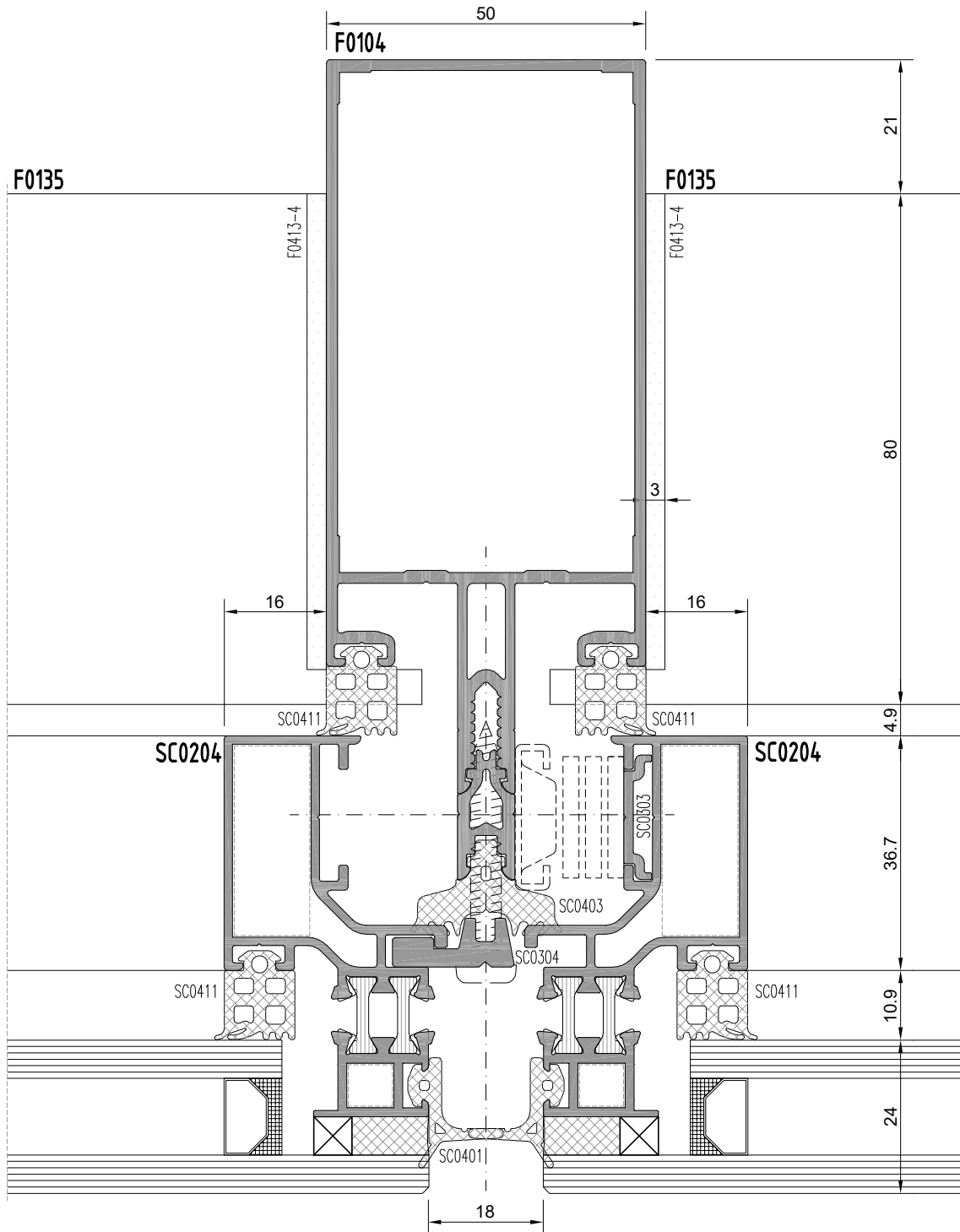
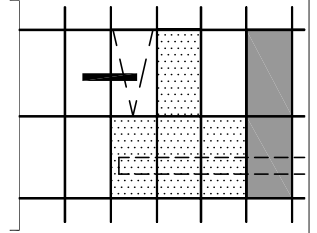

F50 KONDENS SİSTEM
SİLİKON CEPHE
F50 CONDENSAT SYSTEM
SILICONE FACADE

KANAT - SPANDREL
SASH-SPANDREL

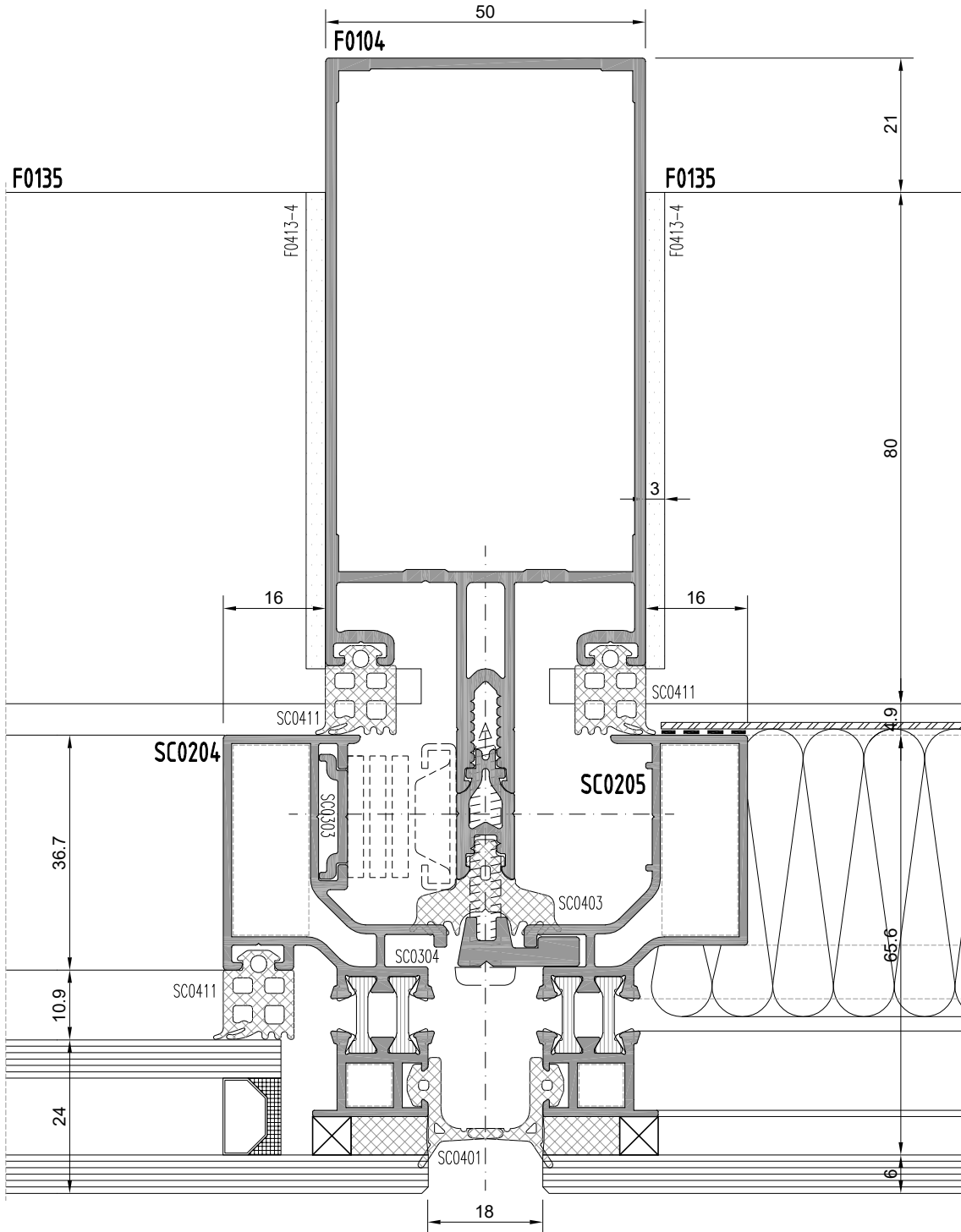
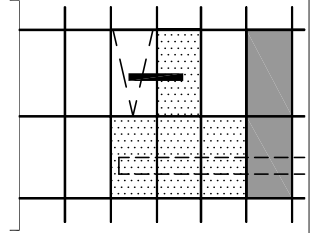

F50 KONDENS SİSTEM
SİLİKON CEPHE
F50 CONDENSAT SYSTEM
SILICONE FACADE

SPANDREL - SABİT
SPANDREL-FIXED

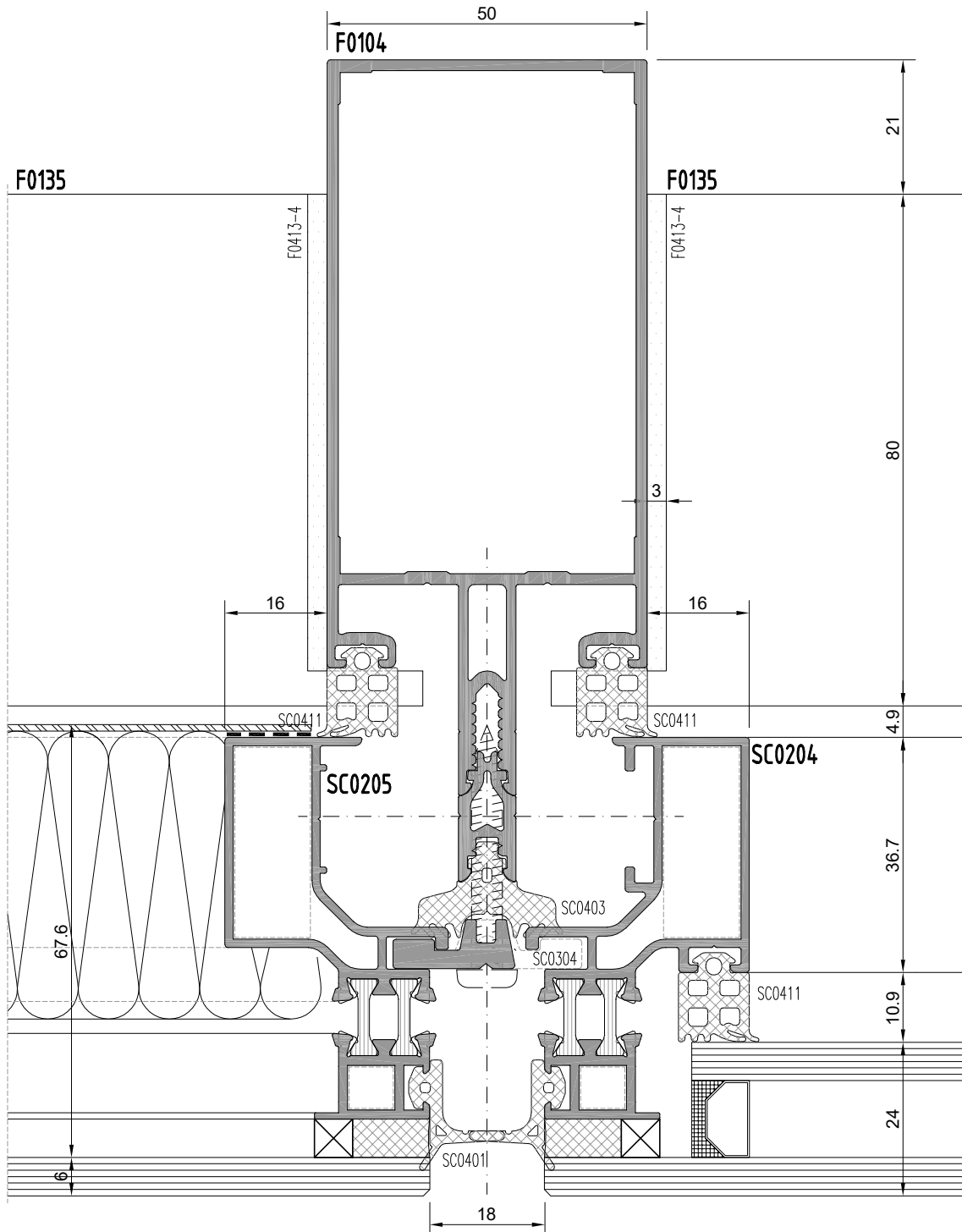
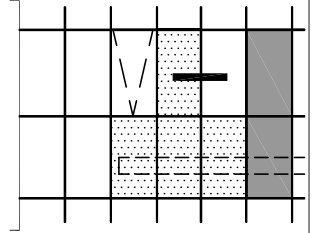

F50 KONDENS SİSTEM
SİLİKON CEPHE
F50 CONDENSAT SYSTEM
SILICONE FACADE

SABİT - KOMPOZİT
FIXED-COMPOSITE

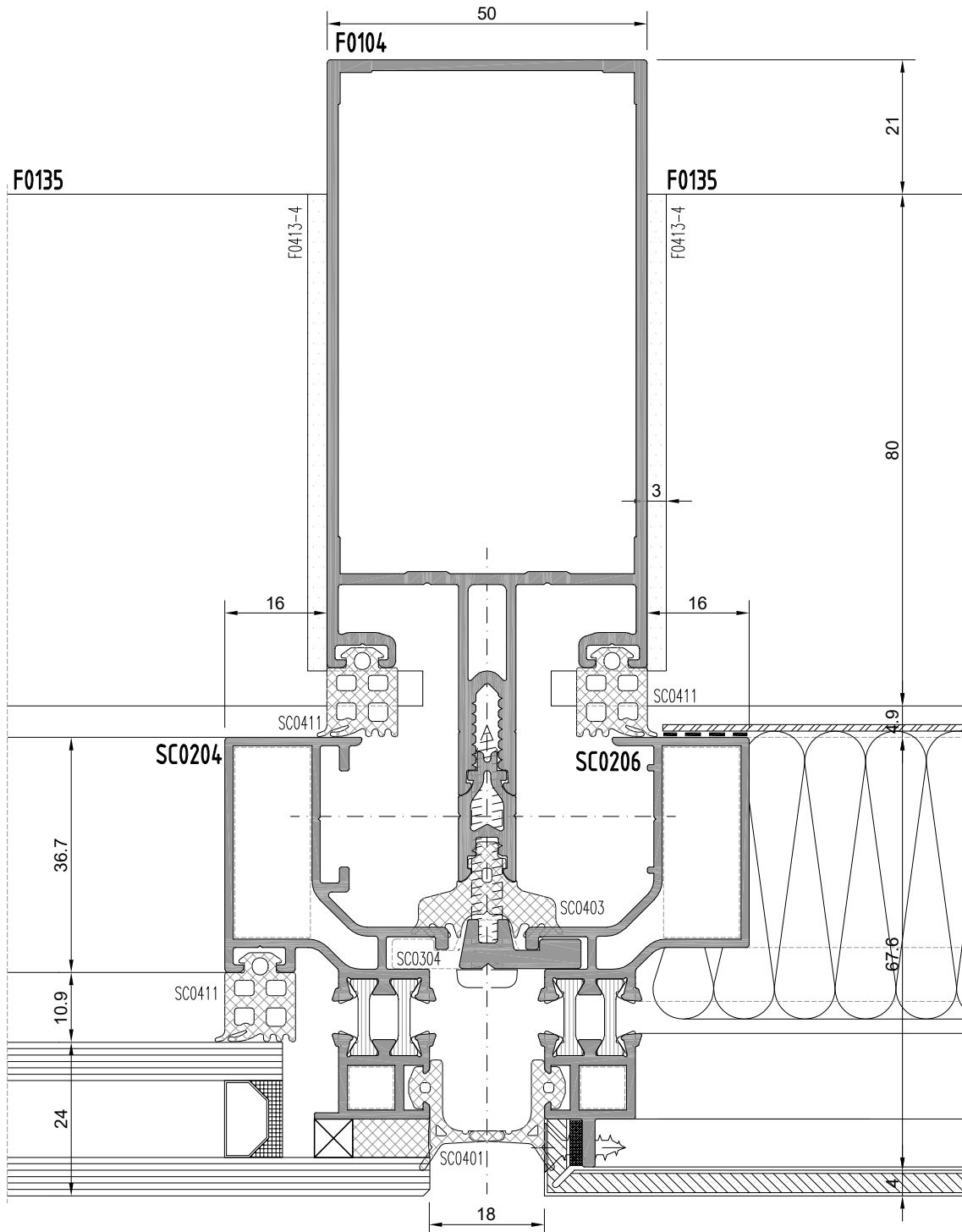
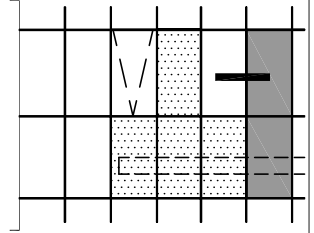

F50 KONDENS SİSTEM
SİLİKON CEPHE
F50 CONDENSAT SYSTEM
SILICONE FACADE

SABIT - KANAT
FIXED-SASH

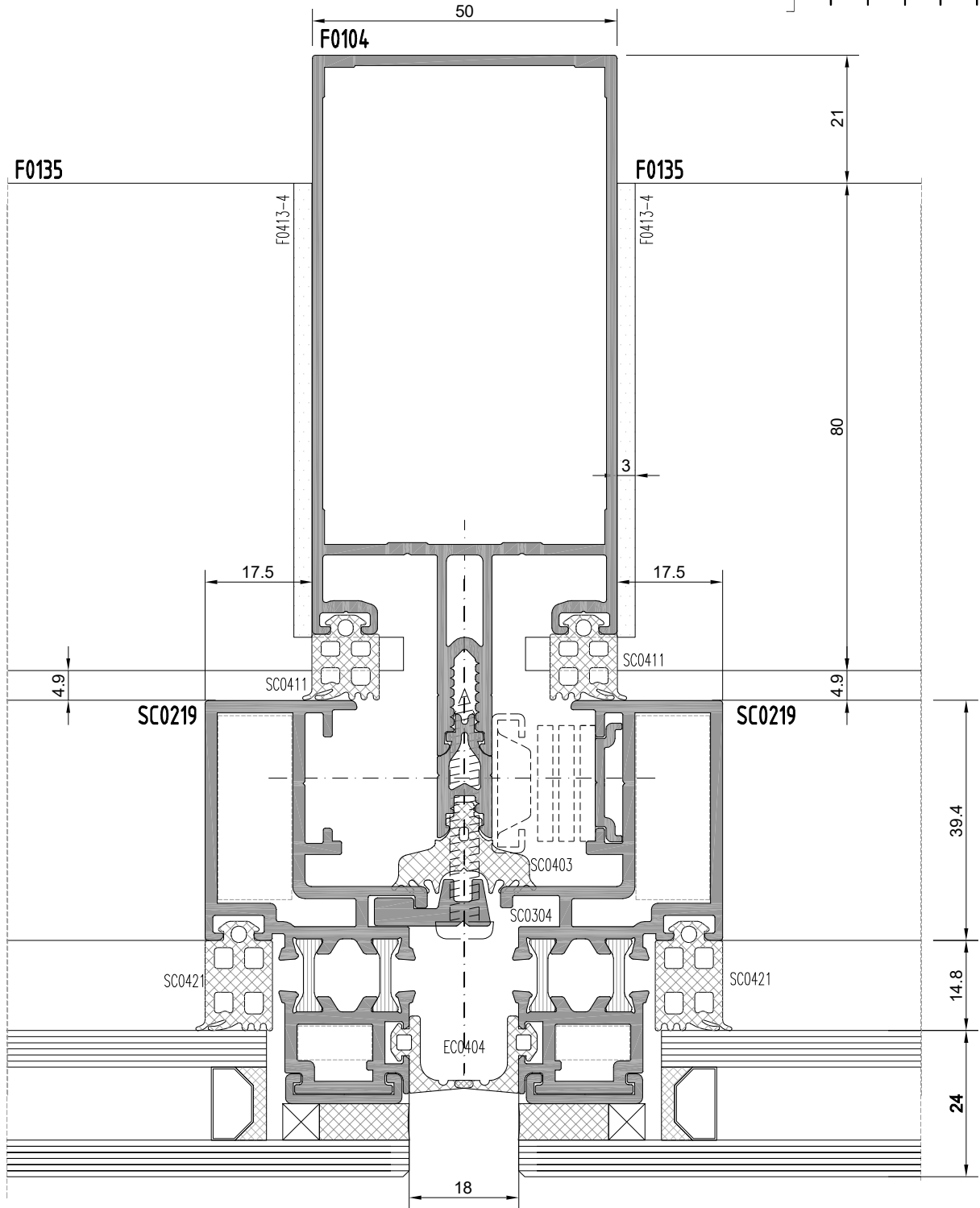
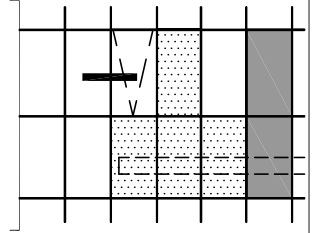

F50 KONDENS SİSTEM
SİLİKON CEPHE
F50 CONDENSAT SYSTEM
SILICONE FACADE

SABİT - SABİT
FIXED-FIXED

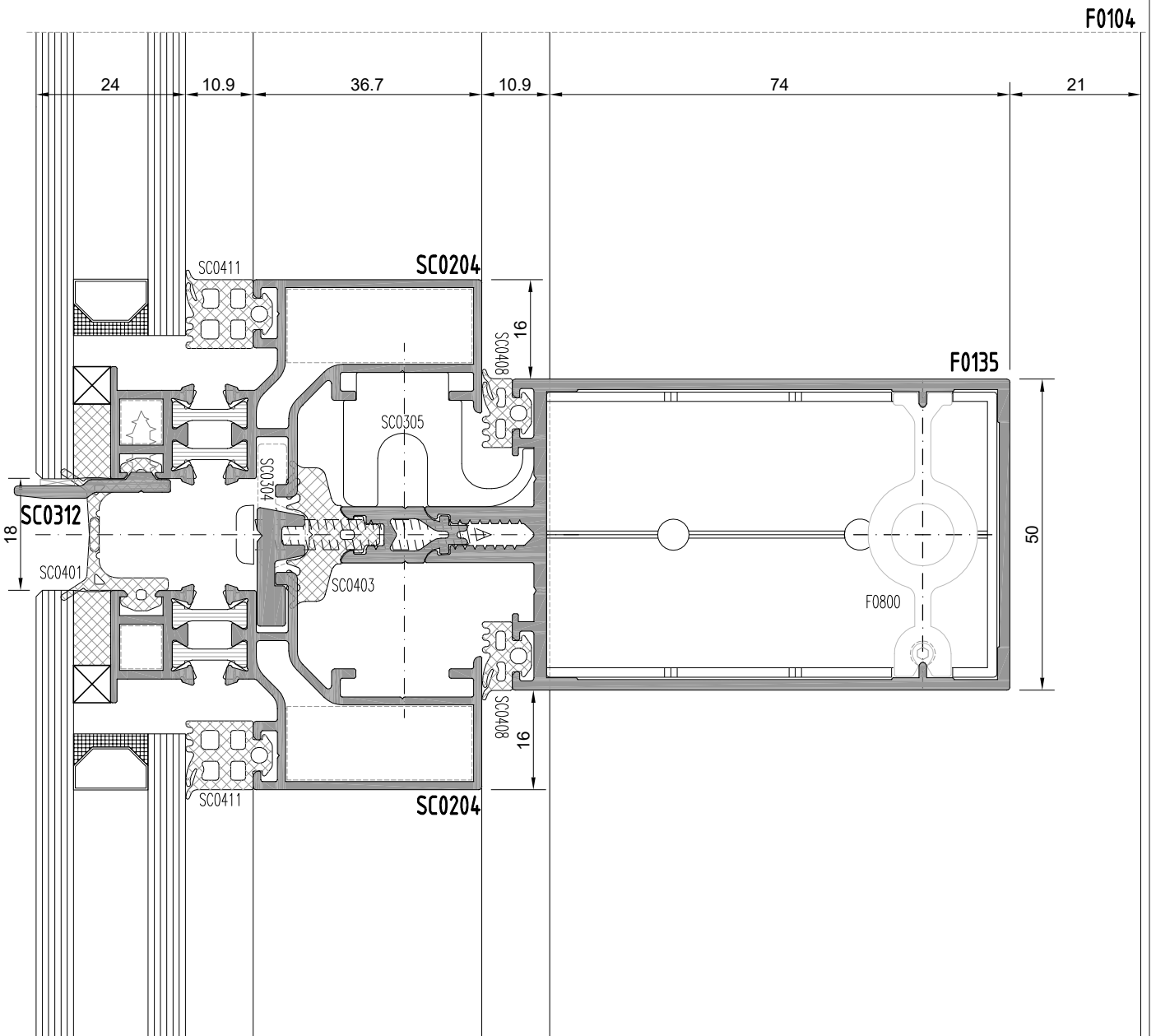
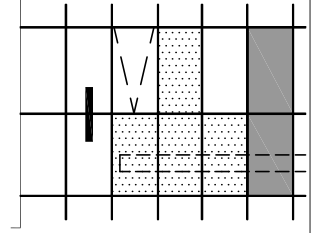

F50 KONDENS SİSTEM
SİLİKON CEPHE
F50 CONDENSAT SYSTEM
SILICONE FACADE

KANAT - SPANDREL
SASH-SPANDREL

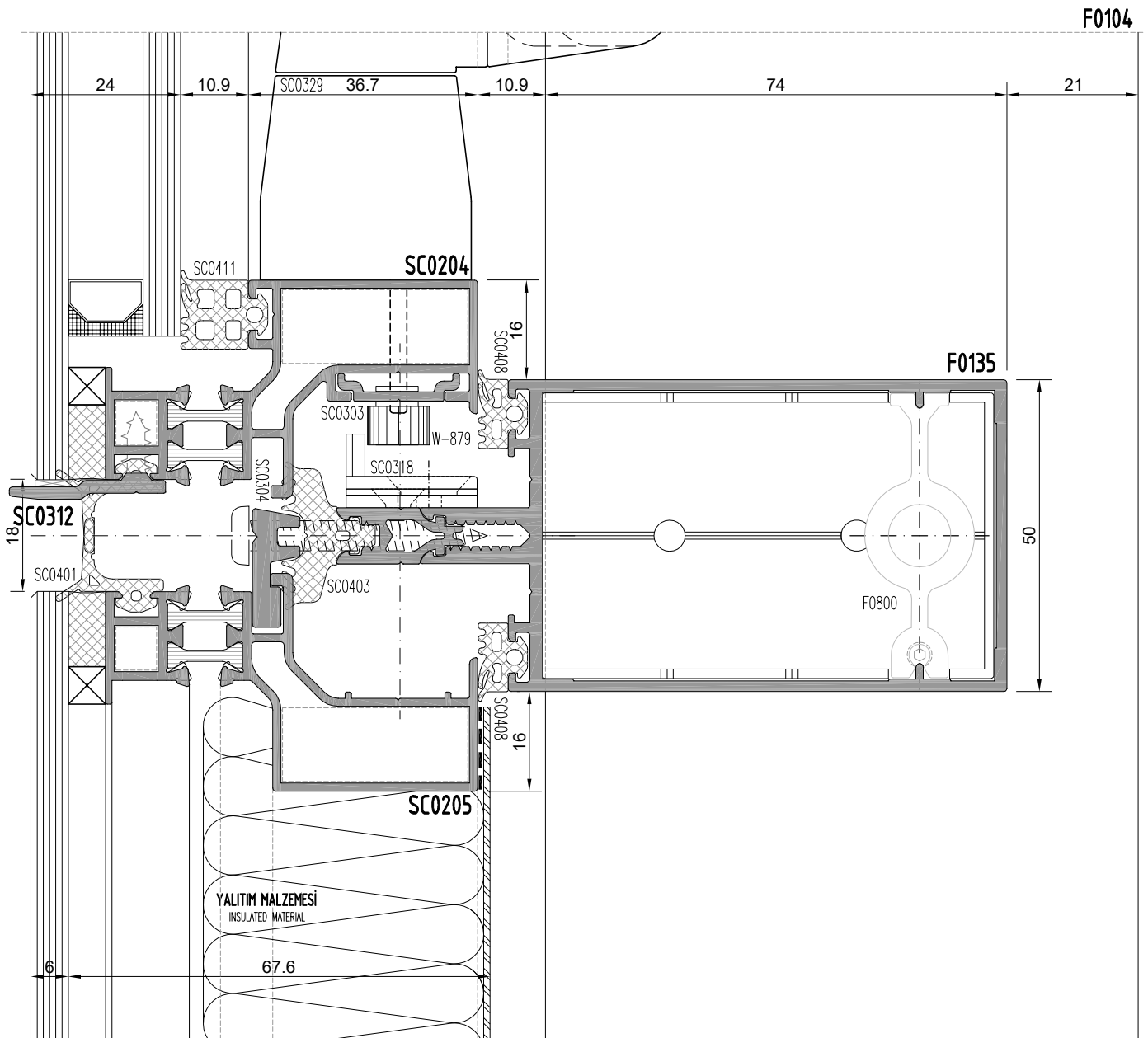
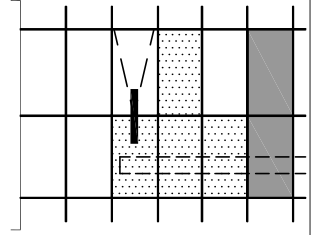

F50 KONDENS SİSTEM
SİLİKON CEPHE
F50 CONDENSAT SYSTEM
SILICONE FACADE

SABİT - SPANDREL
FIXED-SPANDREL

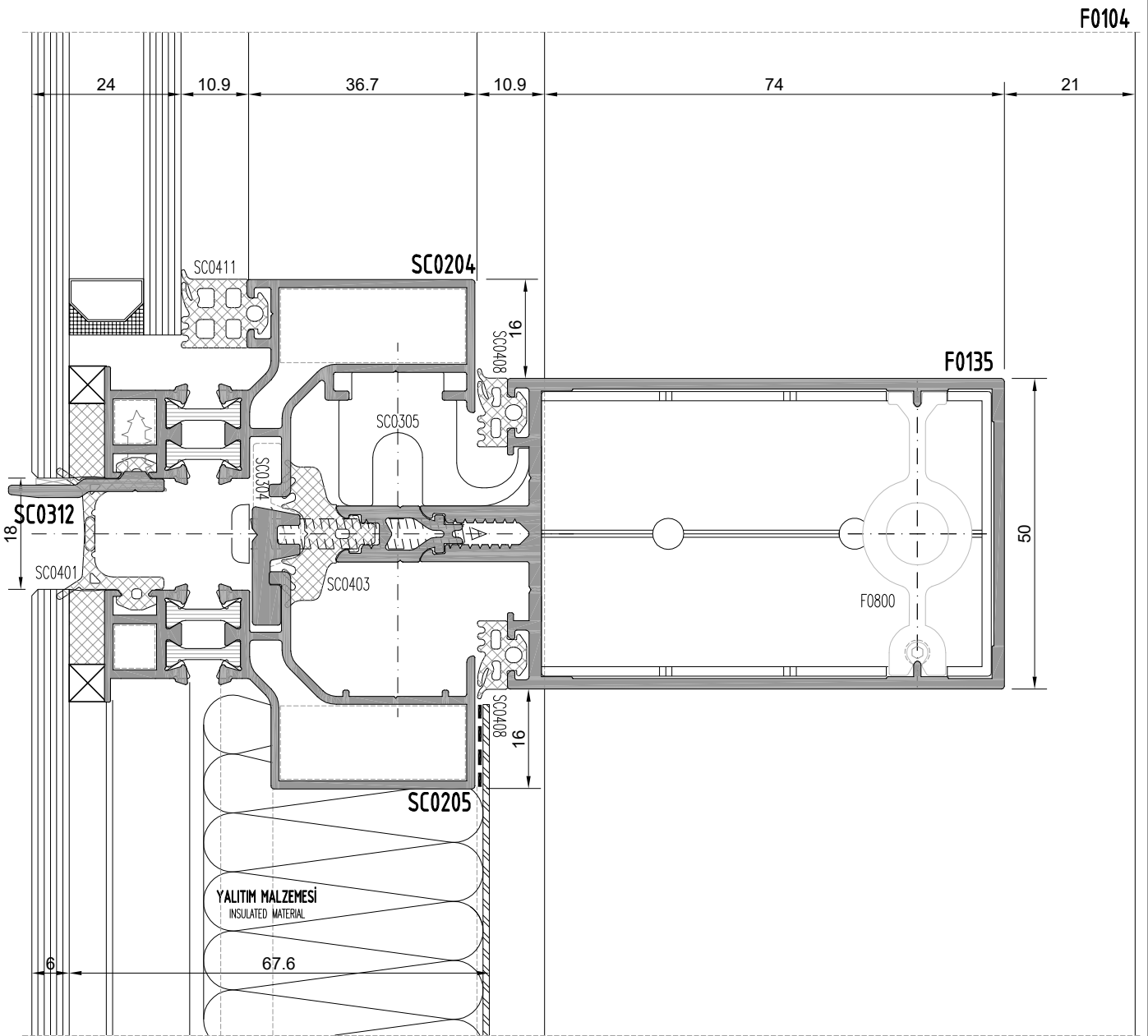
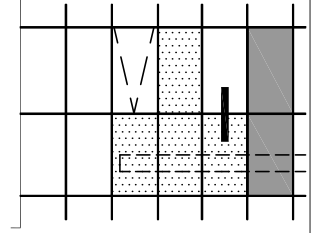

F50 KONDENS SİSTEM
SİLİKON CEPHE
F50 CONDENSAT SYSTEM
SILICONE FACADE

KOMPOZİT - KOMPOZİT
COMPOSITE-COMPOSITE

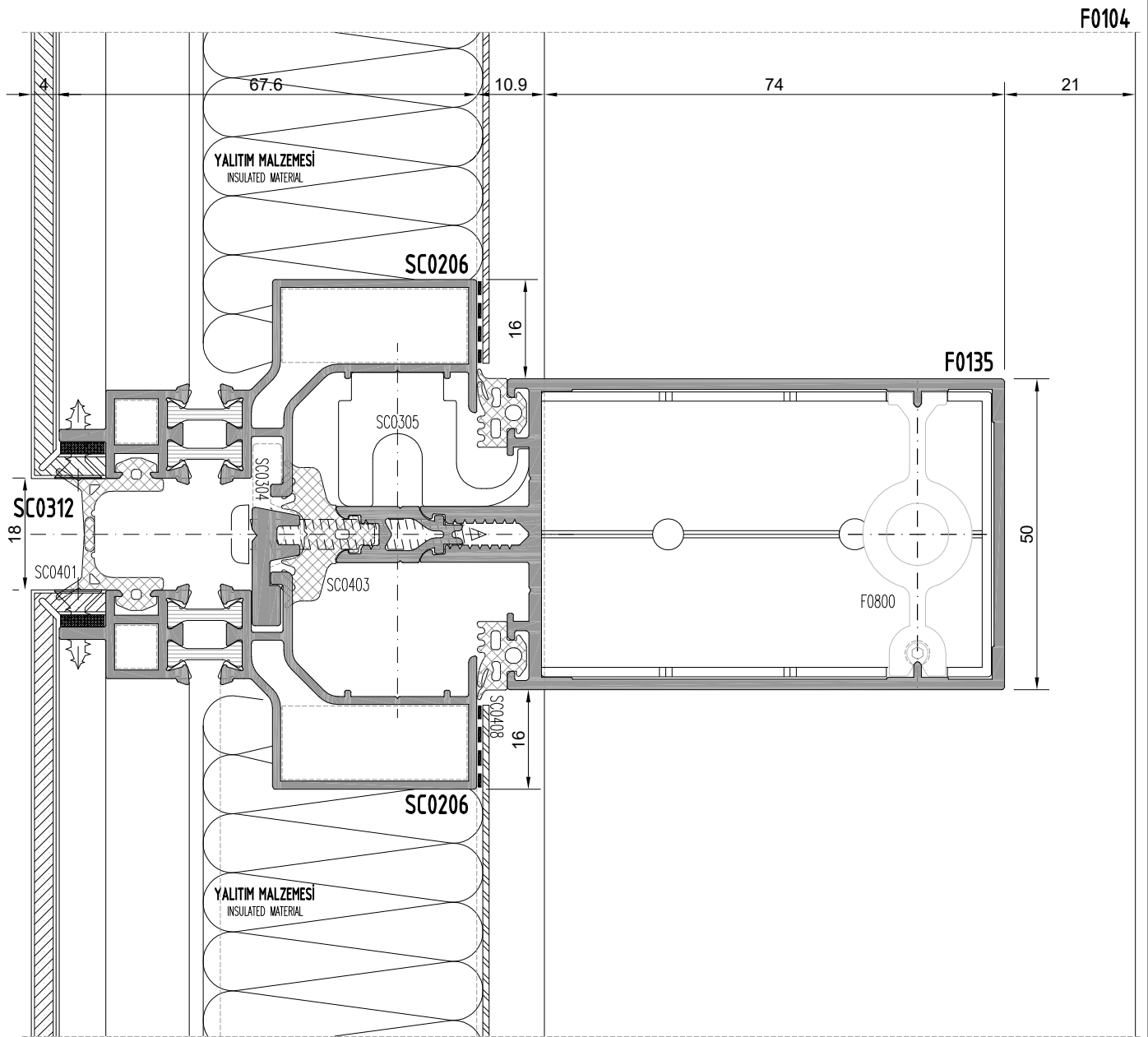
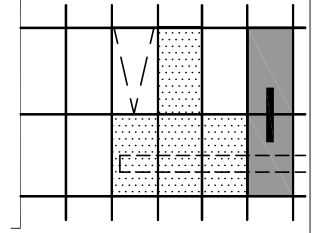

F50 KONDENS SİSTEM
SİLİKON CEPHE
F50 CONDENSAT SYSTEM
SILICONE FACADE

SABIT - KANAT
FIXED-SASH

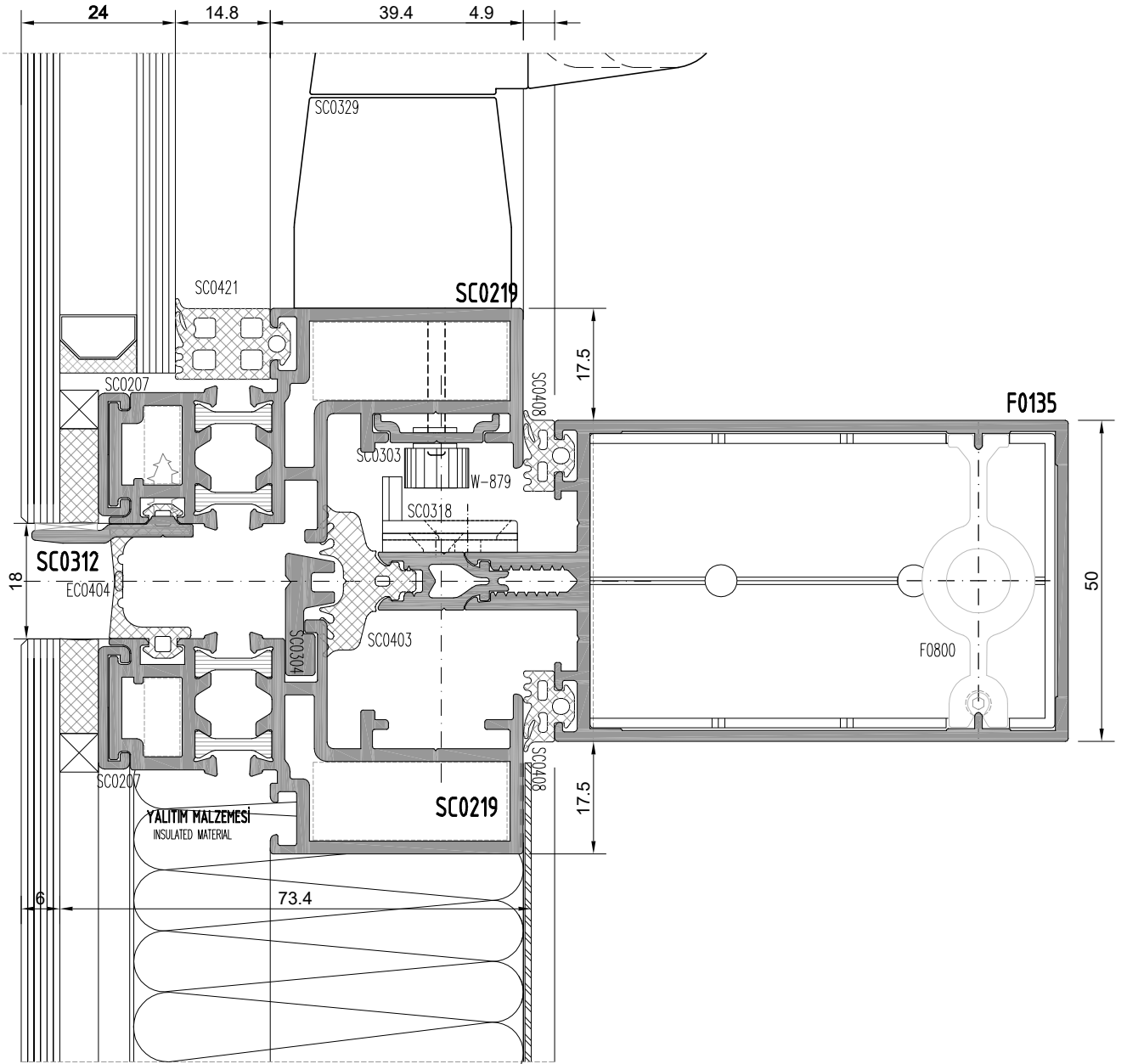
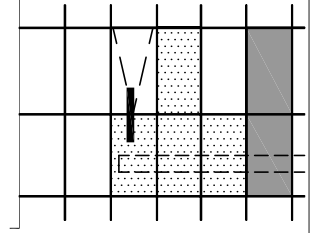

F50 KONDENS SİSTEM
SİLİKON CEPHE
F50 CONDENSAT SYSTEM
SILICONE FACADE

SABİT - SABİT
FIXED-FIXED

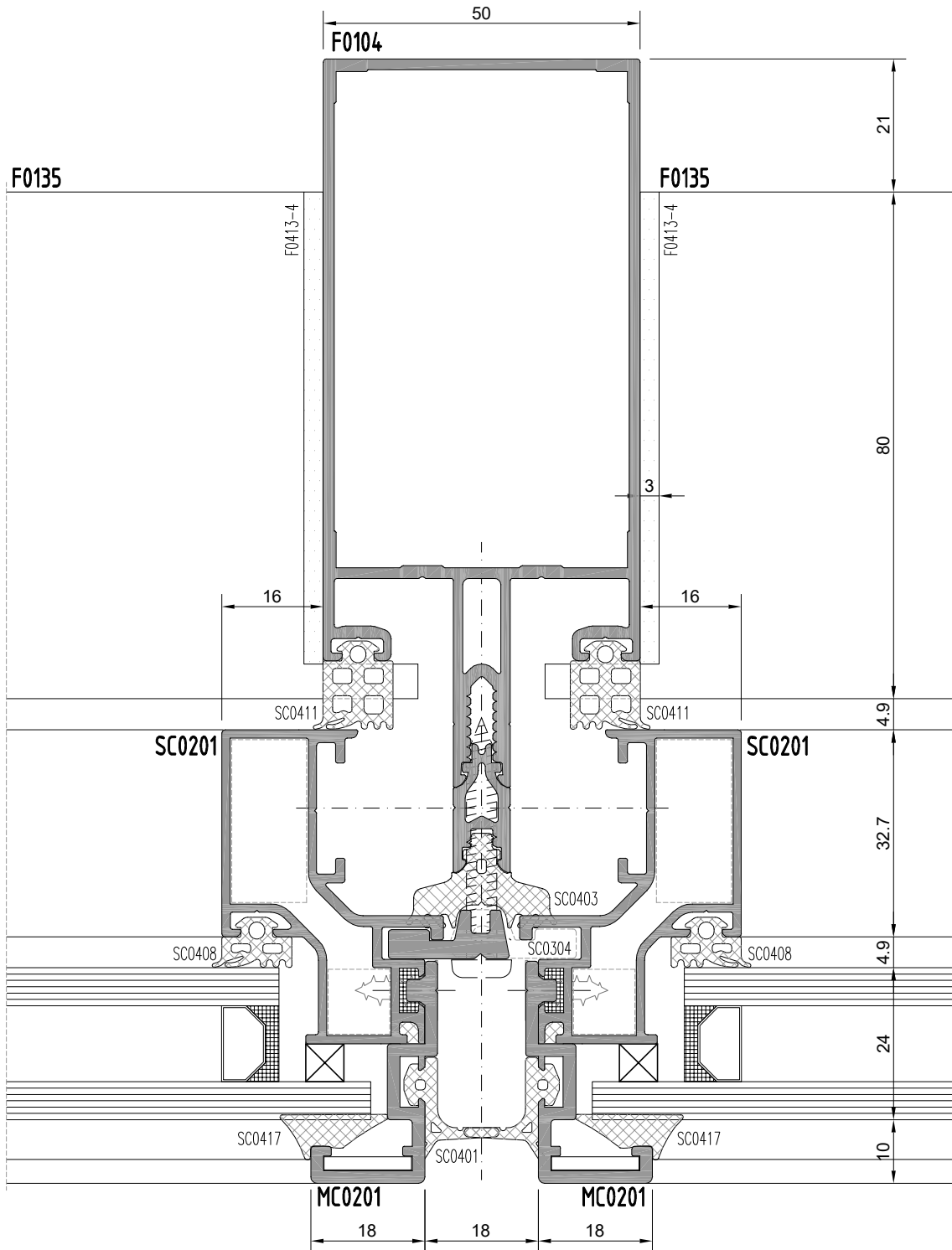
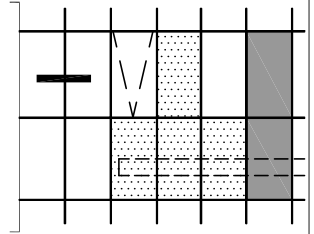

F50 KONDENS SİSTEM
SİLİKON CEPHE
F50 CONDENSAT SYSTEM
SILICONE FACADE

SABİT - KANAT
FIXED-SASH

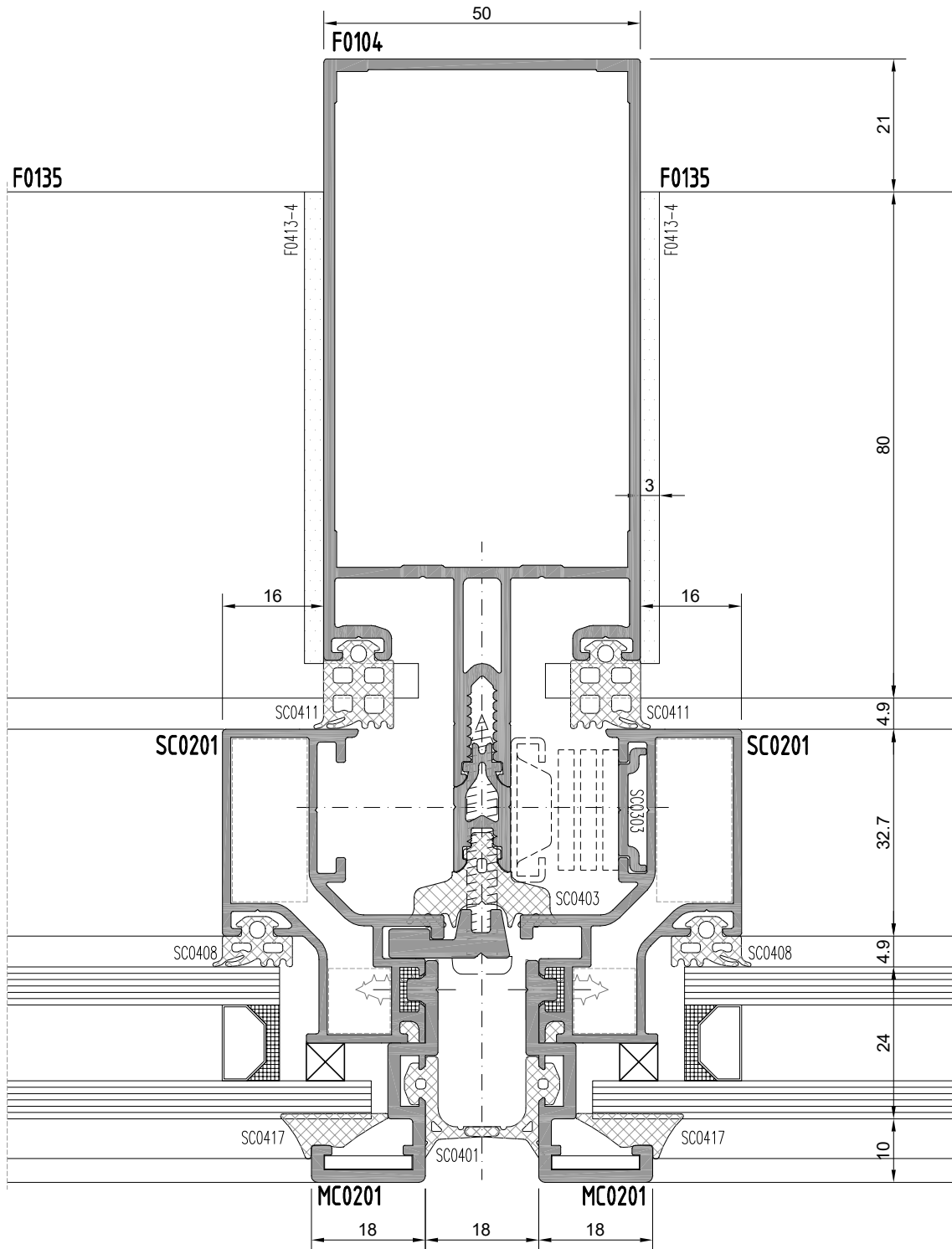
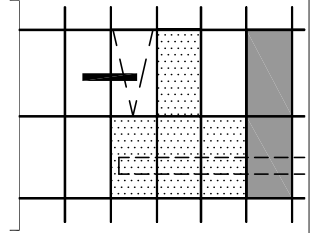

F50 KONDENS SİSTEM
SİLİKON CEPHE
F50 CONDENSAT SYSTEM
SILICONE FACADE

KANAT - SPANDREL
SASH-SPANDREL

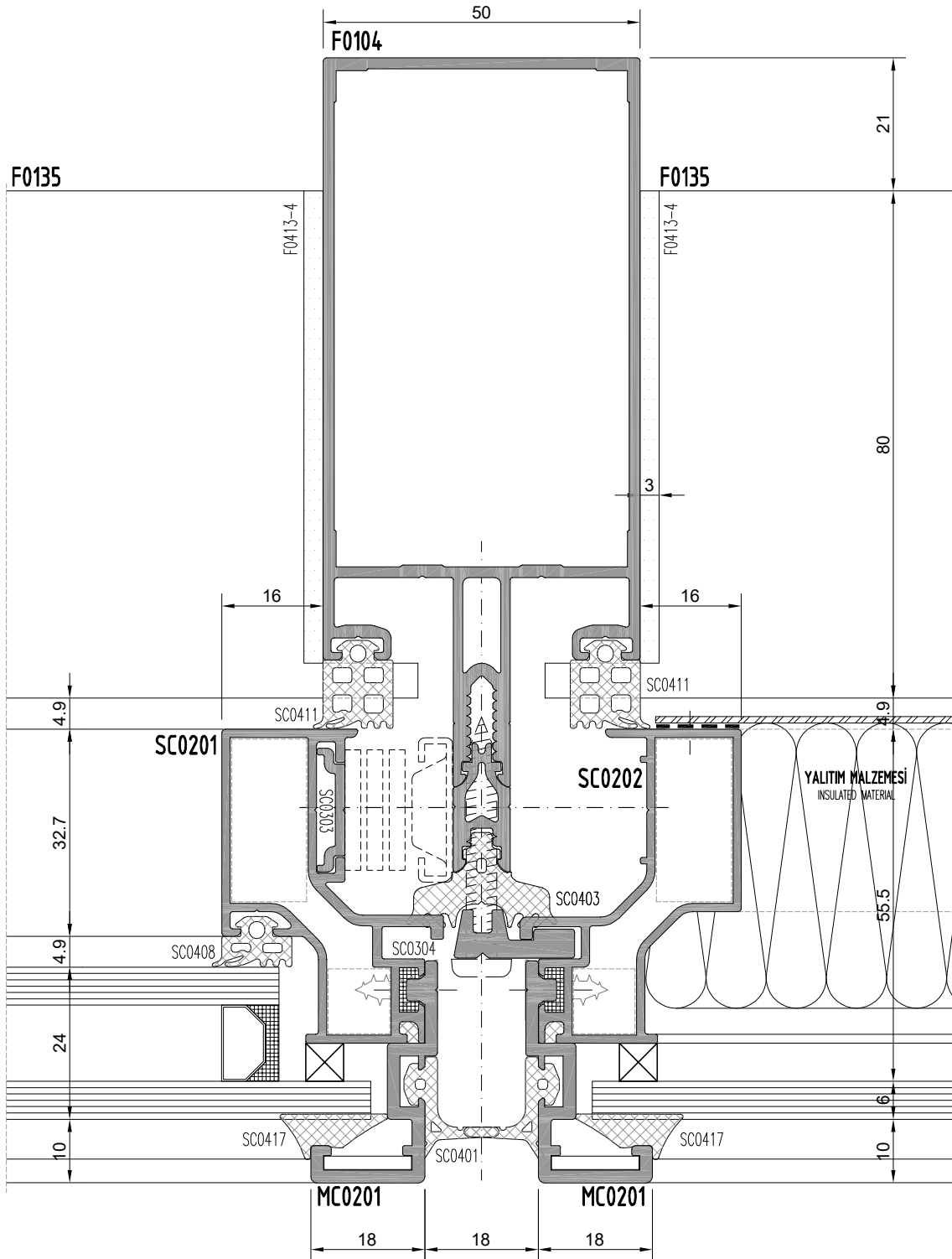
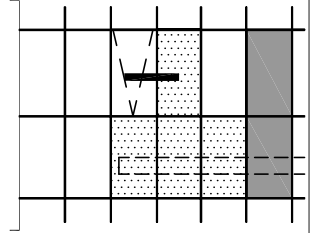

F50 KONDENS SİSTEM
SİLİKON CEPHE
F50 CONDENSAT SYSTEM
SILICONE FACADE

SABİT - KOMPOZİT
FIXED-COMPOSITE

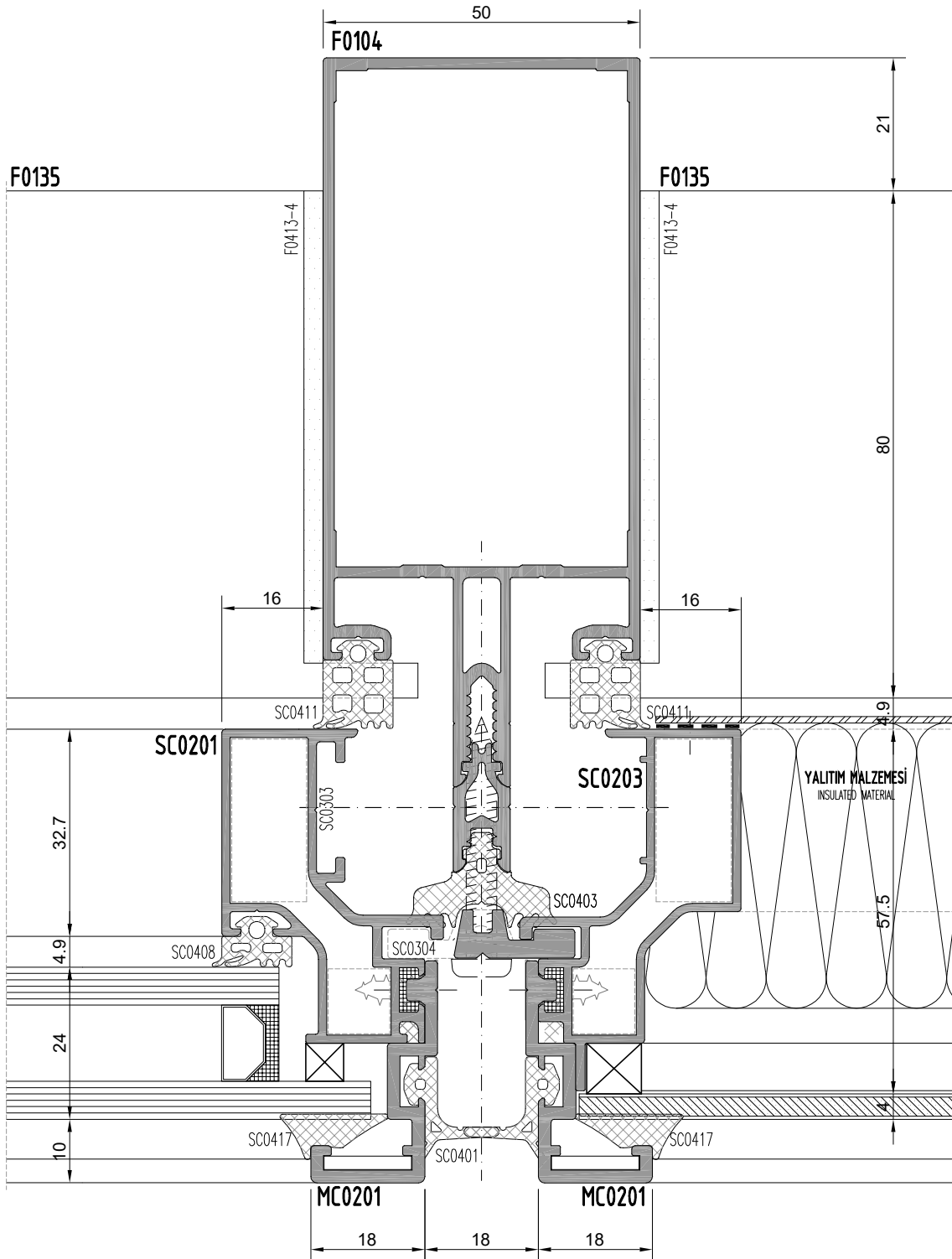
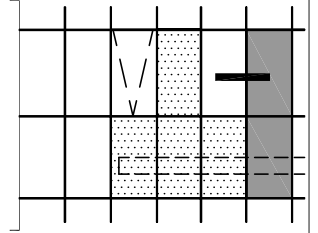

F50 KONDENS SİSTEM
SİLİKON CEPHE
F50 CONDENSAT SYSTEM
SILICONE FACADE

KANAT - SPANDREL
SASH-SPANDREL

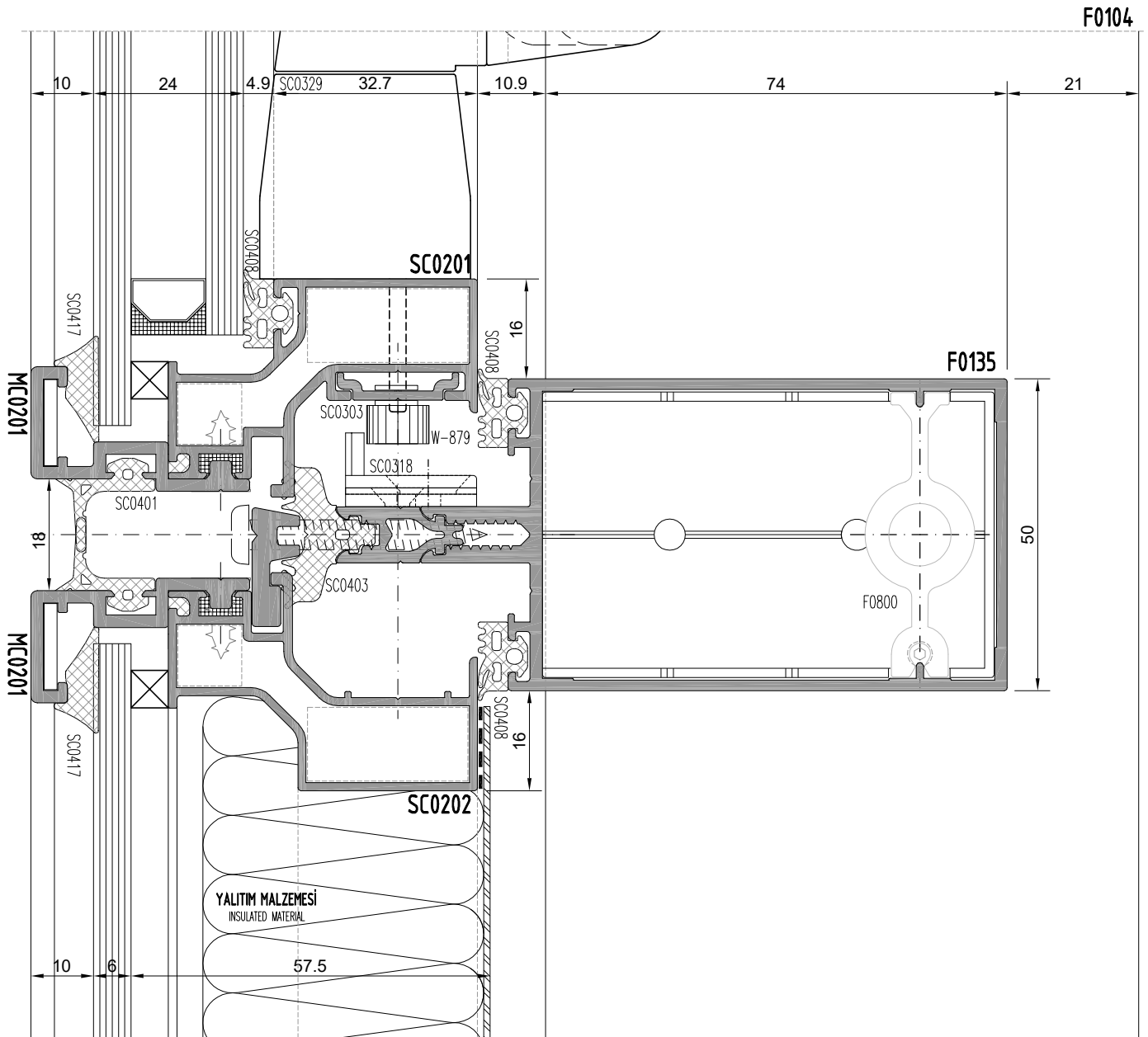
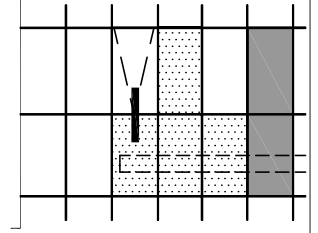

F50 KONDENS SİSTEM
SİLİKON CEPHE
F50 CONDENSAT SYSTEM
SILICONE FACADE

KOMPOZİT - KOMPOZİT
COMPOSITE-COMPOSITE

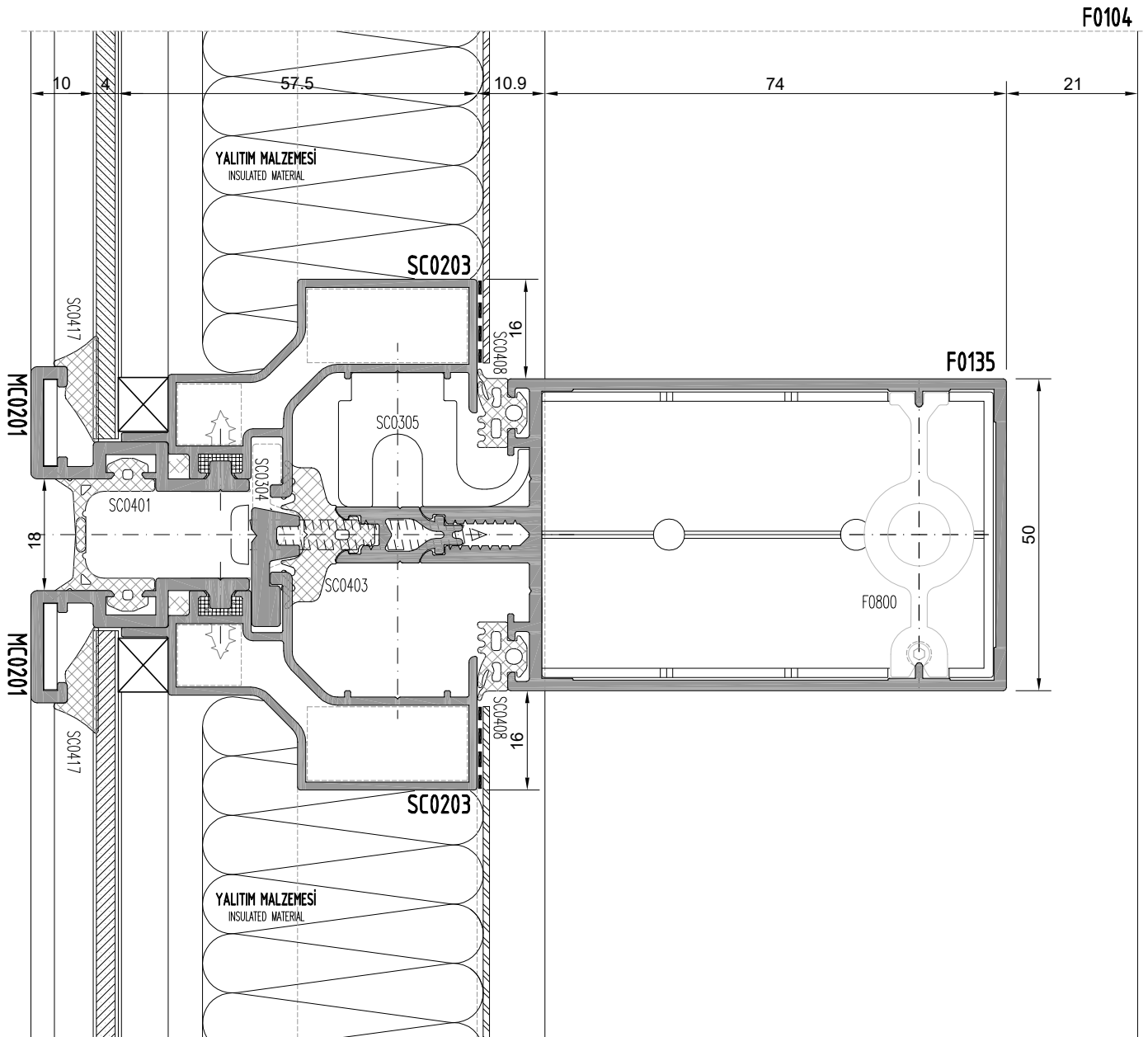
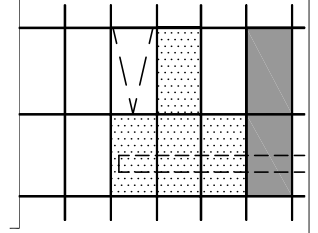

F50 KONDENS SİSTEM

SİLİKON CEPHE

F50 CONDENSAT SYSTEM
SILICONE FACADE

SABIT - SABİT
FIXED-FIXED

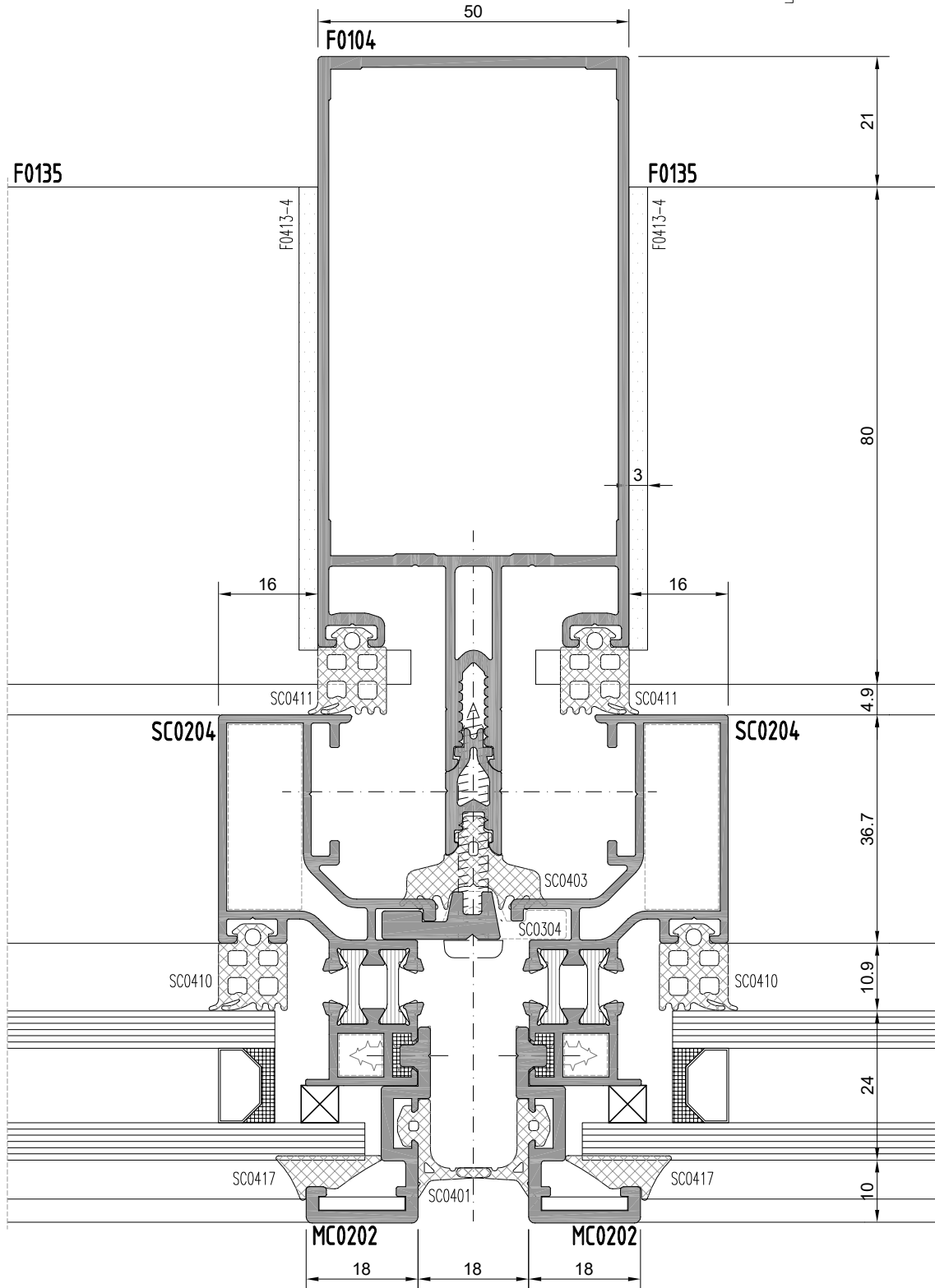
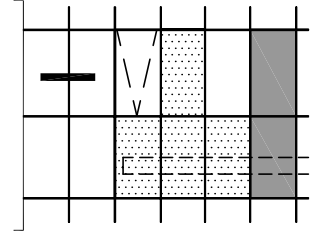

F50 KONDENS SİSTEM

SİLİKON CEPHE

F50 CONDENSAT SYSTEM
SILICONE FACADE

SABİT - KANAT
FIXED-SASH

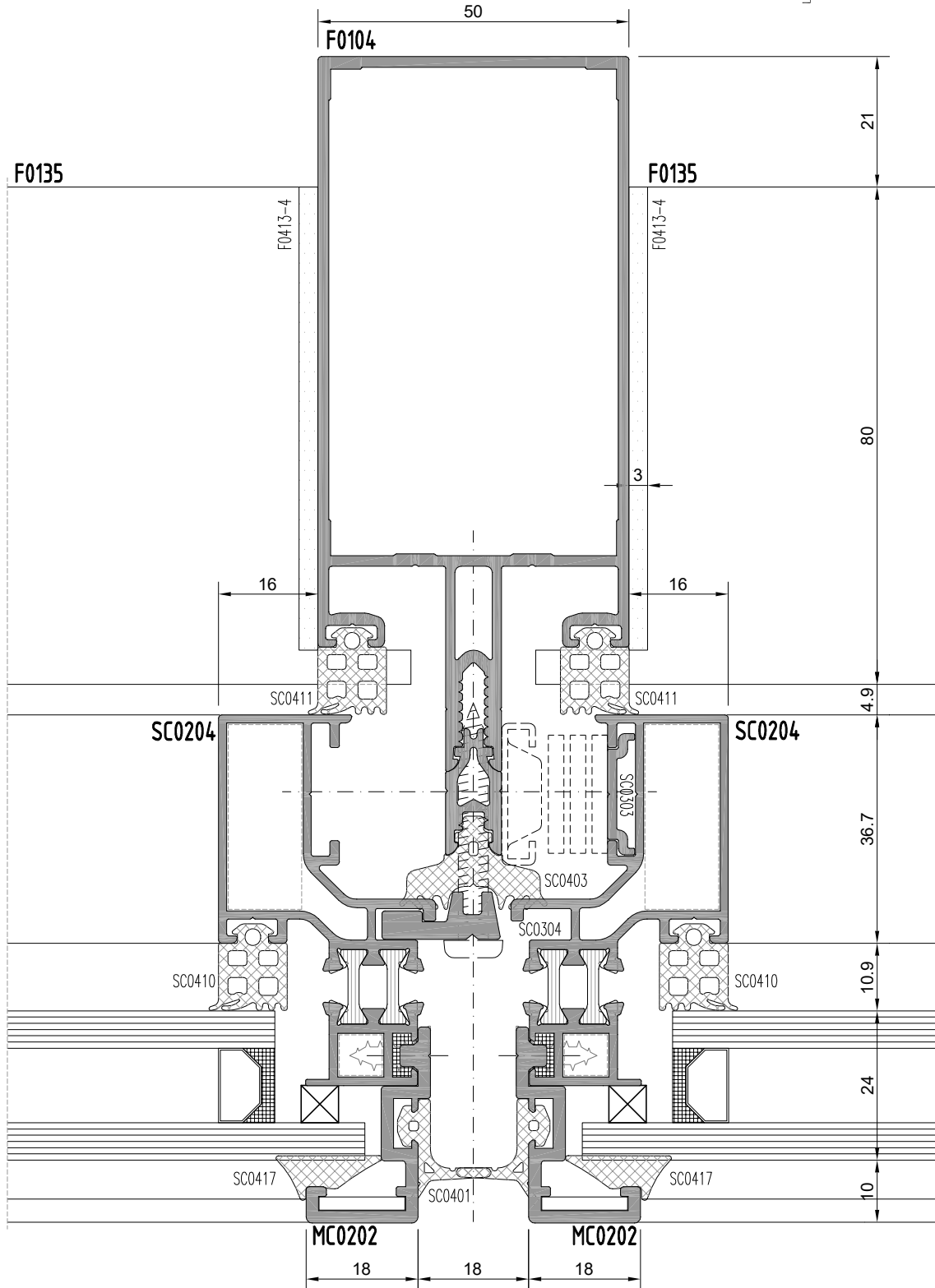
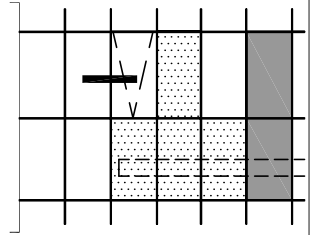

F50 KONDENS SİSTEM
SİLİKON CEPHE
F50 CONDENSAT SYSTEM
SILICONE FACADE

SABİT - SABİT
FIXED-FIXED

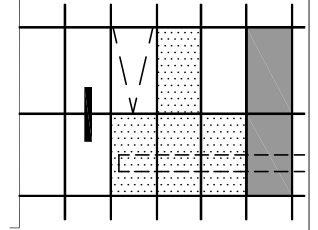

F0104

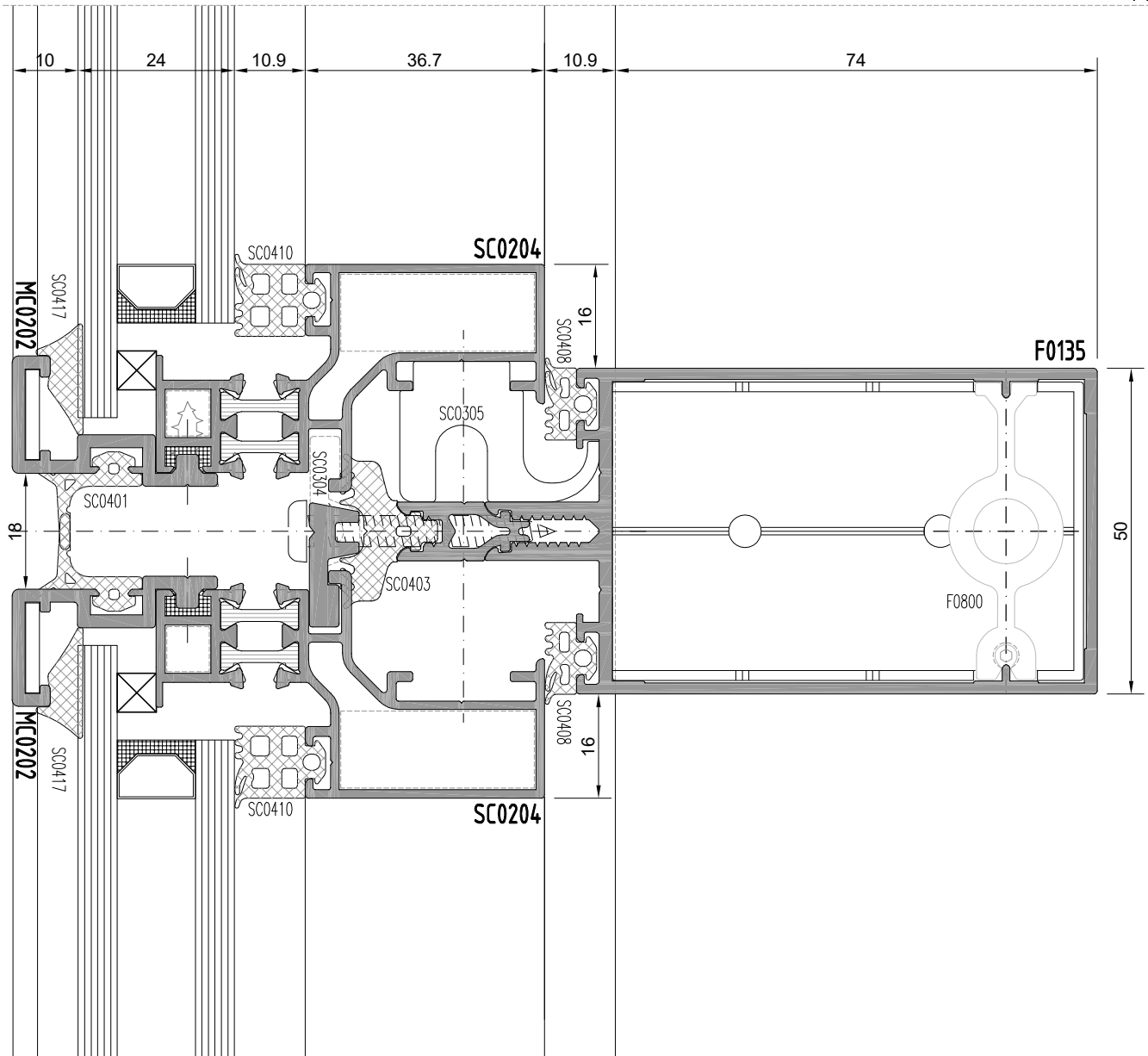

F50 KONDENS SİSTEM
SİLİKON CEPHE
F50 CONDENSAT SYSTEM
SILICONE FACADE

SPANDREL - SPANDREL
SPANDREL-SPANDREL

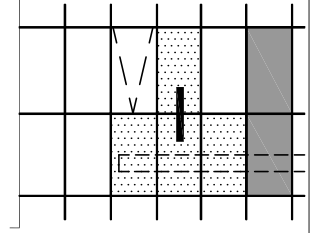

F0104

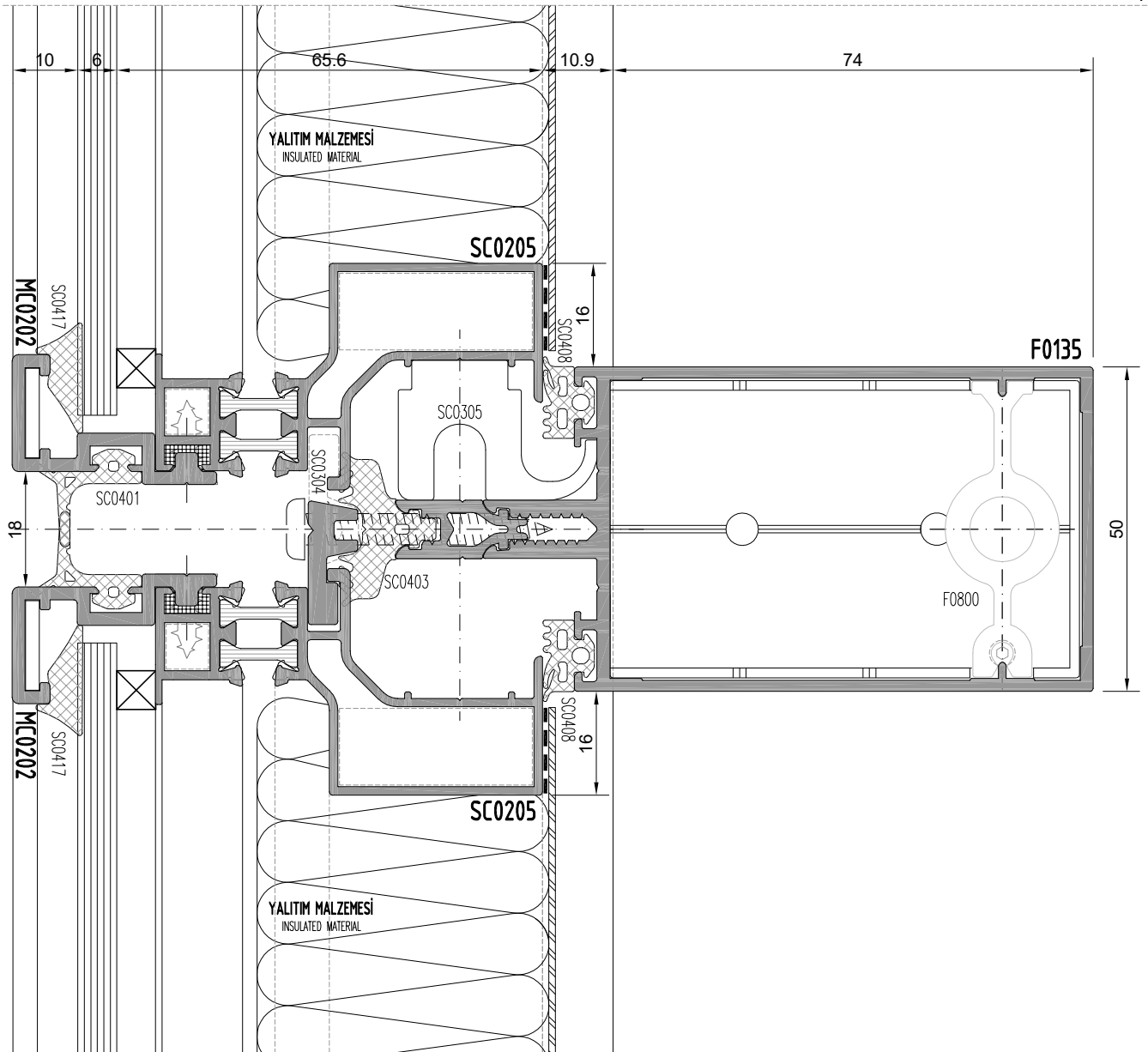

F50 KONDENS SİSTEM
SİLİKON CEPHE
F50 CONDENSAT SYSTEM
SILICONE FACADE

KOMPOZİT - KOMPOZİT
COMPOSITE-COMPOSITE

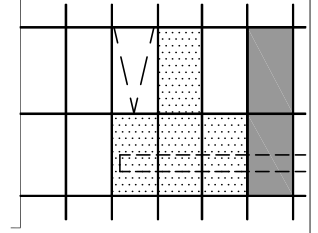

F0104

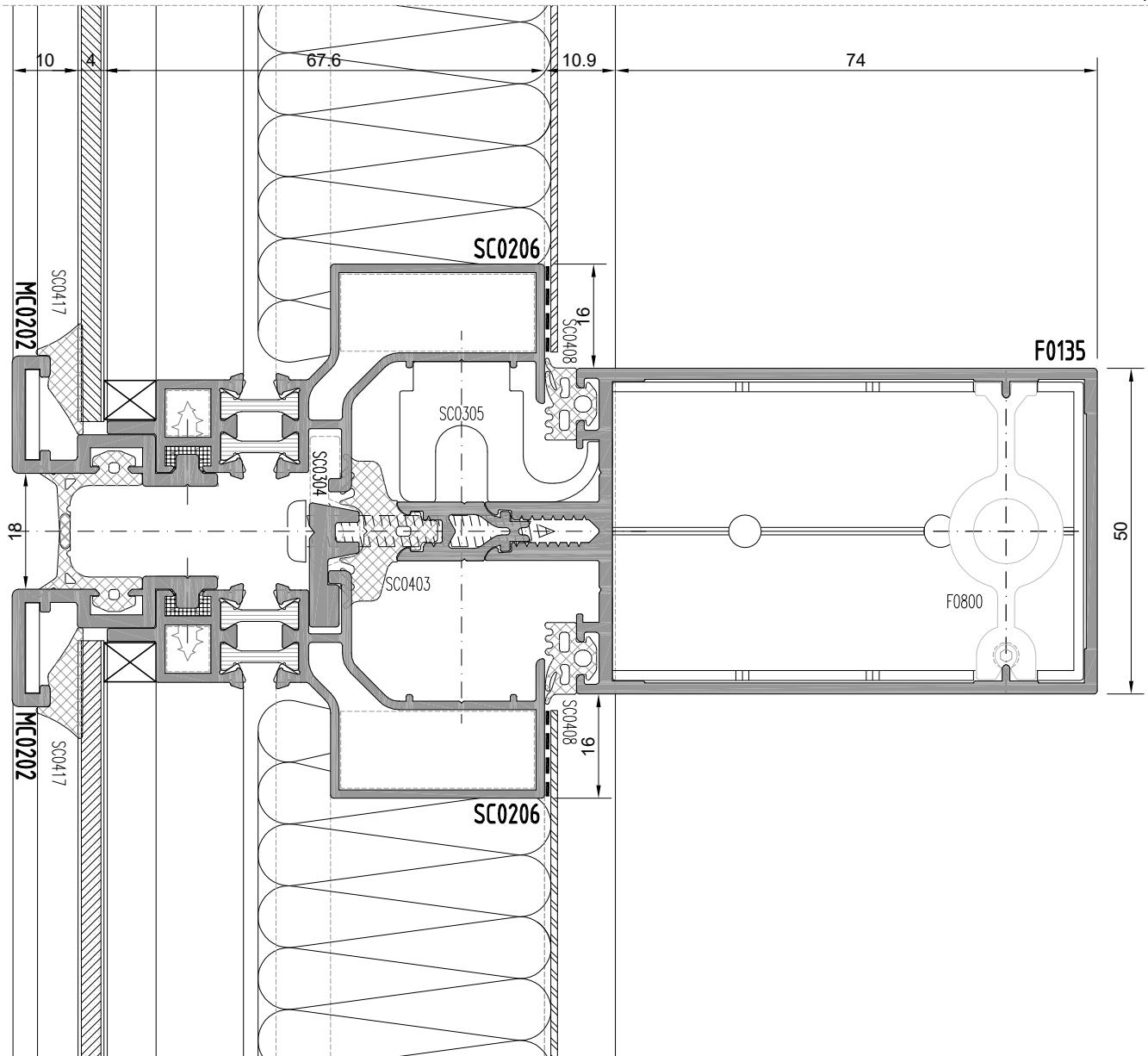

F50 KONDENS SİSTEM
SİLİKON CEPHE
F50 CONDENSAT SYSTEM
SILICONE FACADE

SABIT - KANAT
FIXED-SASH

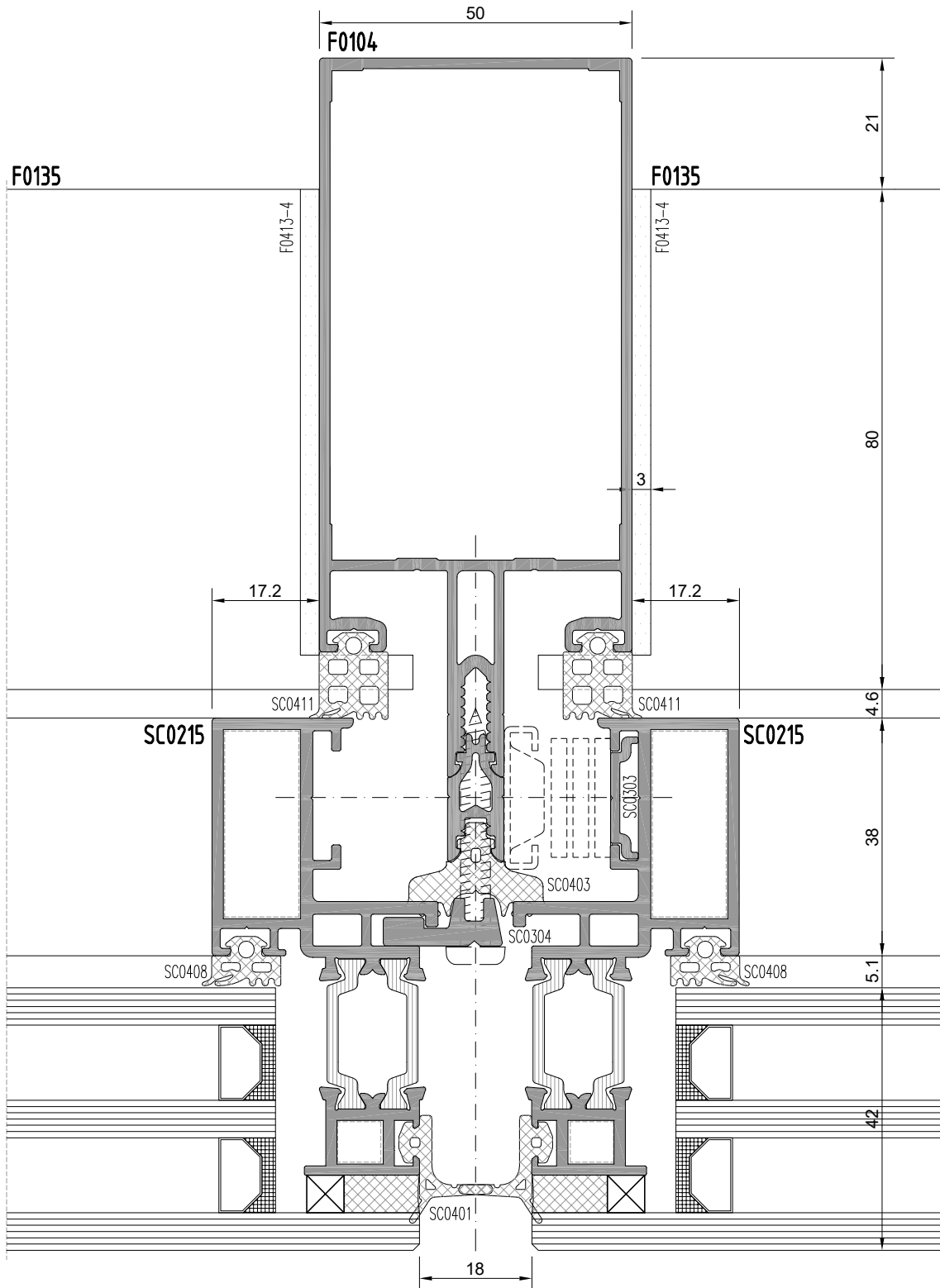
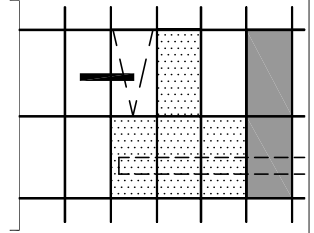

F50 KONDENS SİSTEM
SİLİKON CEPHE
F50 CONDENSAT SYSTEM
SILICONE FACADE

SABİT - SABİT
FIXED-FIXED

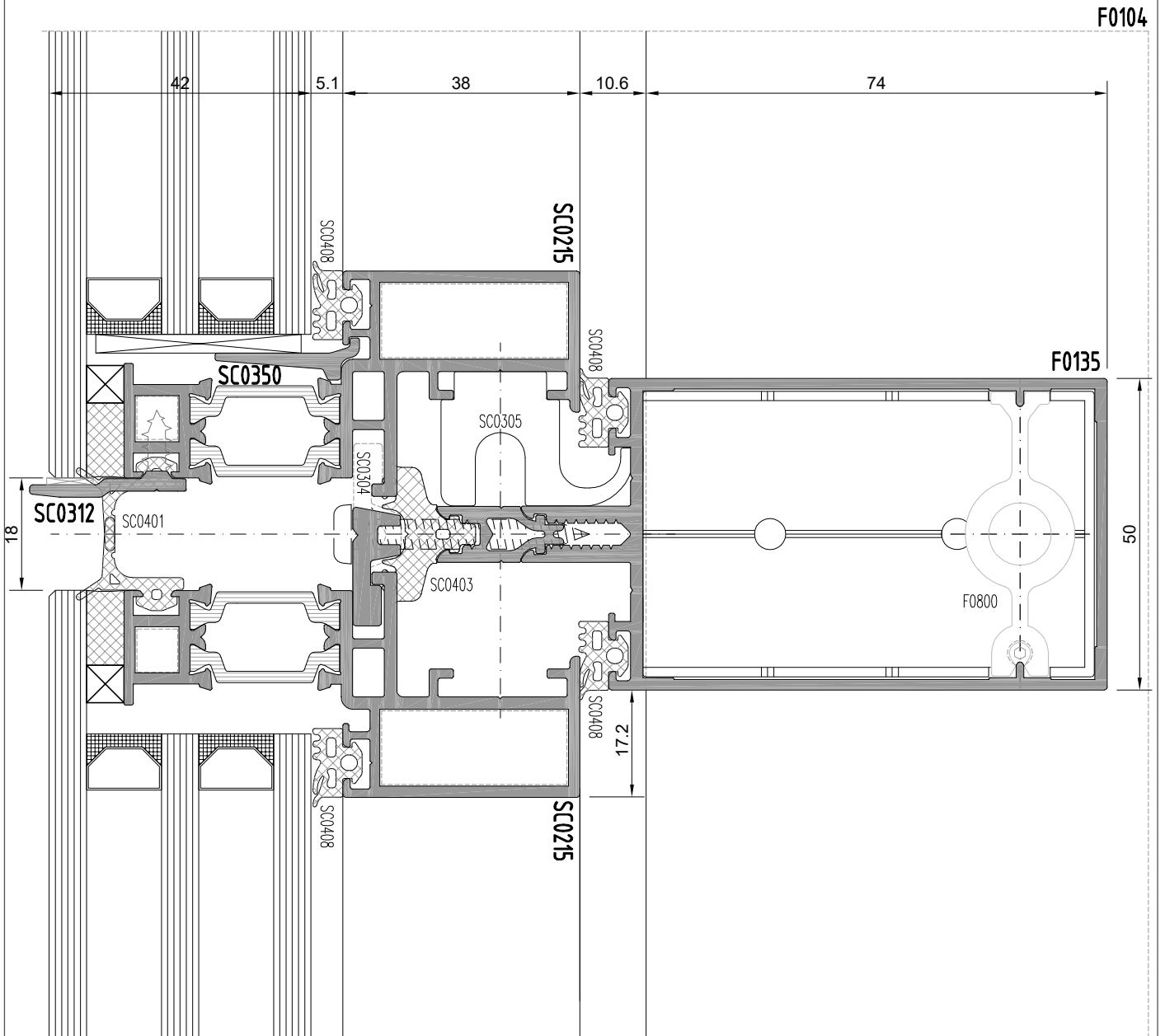
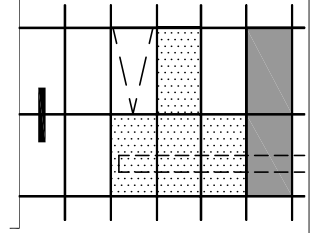

F50 KONDENS SİSTEM

SİLİKON CEPHE

F50 CONDENSAT SYSTEM
SILICONE FACADE

Fitil listesi
Gasket list

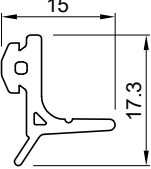
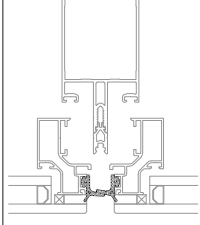
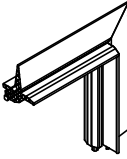
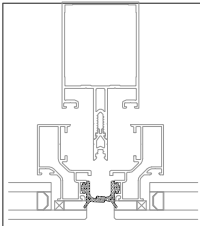
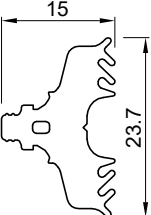
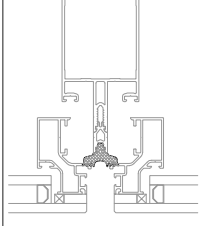
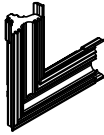
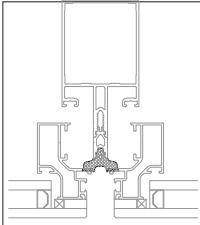
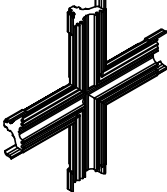
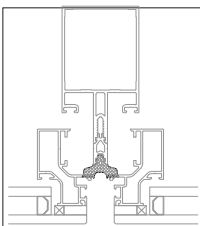
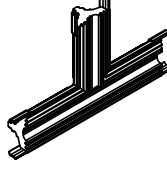
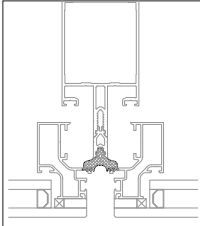
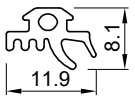
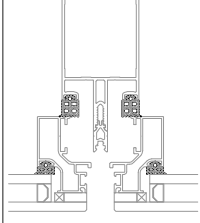
kod code	şekil drawing	tanım description	teorik ağırlık theoretical weight gr / m	paket ağırlığı package weight kg / package	paket metrajı in one package metre / package	kullanım yeri aplication
SC0401		Panel dış fitili Frame gasket	74 gr/m	15 kg	202 m	
SC0402		Panel dış fitili (köşe) Frame gasket (corner)	89 gr/m	-	50 ad-pcs	
SC0403		Taşıyıcı ön fitili Mullion or transom front gasket	173 gr/m	15 kg	76 m	
SC0404		Taşıyıcı ön fitili (L merkez) Mullion or transom front gasket (L center)	17,6 gr/ad	-	50 ad-pcs	
SC0405		Taşıyıcı ön fitili (T merkez) Mullion or transom front gasket (T center)	31,6 gr/ad	-	50 ad-pcs	
SC0406		Taşıyıcı ön fitili (+ merkez) Mullion or transom front gasket (+ center)	24,6 gr/ad	-	50 ad-pcs	
SC0422		Taşıyıcı ve Panel iç fitili Mullion-transom or Panel gasket inside	46 gr/m	15 kg	326 m	

F50 KONDENS SİSTEM

SİLİKON CEPHE

F50 CONDENSAT SYSTEM
SILICONE FACADE

Fıtıl listesi
Gasket list

kod code	şekil drawing	tanım description	teorik ağırlık teoretical weight gr / m	paket ağırlığı package weight kg / package	paket metrajı in one package metre / package	kullanım yeri aplication
SC0407		Taşıyıcı ve Panel iç fitili Mullion-transom or Panel gasket inside	73 gr/m	15 kg	205 m	
SC0408		Taşıyıcı ve Panel iç fitili Mullion-transom or Panel gasket inside	88 gr/m	15 kg	170 m	
SC0409		Taşıyıcı ve Panel iç fitili Mullion-transom or Panel gasket inside	101 gr/m	15 kg	148 m	
SC0410		Taşıyıcı ve Panel iç fitili Mullion-transom or Panel gasket inside	113 gr/m	15 kg	133 m	
SC0411		Taşıyıcı ve Panel iç fitili Mullion-transom or Panel gasket inside	144 gr/m	15 kg	104 m	
SC0420		Taşıyıcı ve Panel iç fitili Mullion-transom or Panel gasket inside	167 gr/m	15 kg	90 m	
SC0421		Taşıyıcı ve Panel iç fitili Mullion-transom or Panel gasket inside	189 gr/m	15 kg	79 m	

F50 KONDENS SİSTEM

SİLİKON CEPHE

F50 CONDENSAT SYSTEM
SILICONE FACADE

Fitil listesi
Gasket list

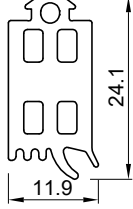
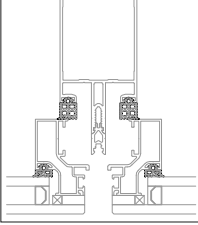
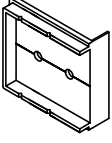
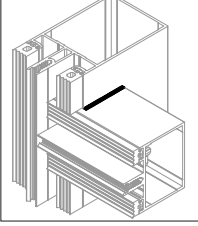
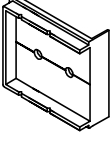
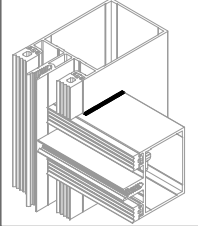
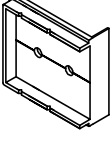
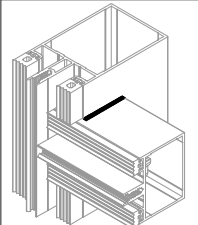
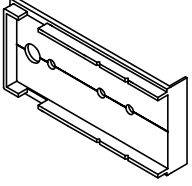
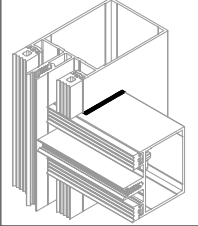
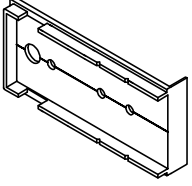
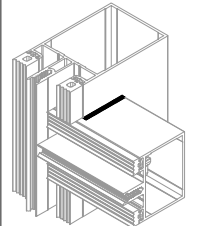
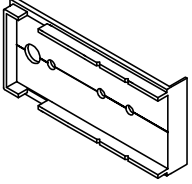
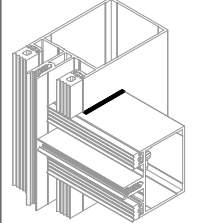
kod code	şekil drawing	tanım description	teorik ağırlık teoretical weight gr / m	paket ağırlığı package weight kg / package	paket metrajı in one package metre / package	kullanım yeri aplication
SC0425		Taşıyıcı ve Panel iç fitili Mullion-transom or Panel gasket inside	217,6 gr/m	15 kg	69 m	
F0413-1		Yaka fitili (20 lik) T-connector Gasket for transom (F0132)	-	-	50 ad-pcs	
F0413-2		Yaka fitili (40 lik) T-connector Gasket for transom (F0133)	-	-	50 ad-pcs	
F0413-3		Yaka fitili (60 lik) T-connector Gasket for transom (F0134)	-	-	50 ad-pcs	
F0413-4		Yaka fitili (80 lik) T-connector Gasket for transom (F0135)	-	-	50 ad-pcs	
F0413-5		Yaka fitili (100 lik) T-connector Gasket for transom (F0136)	-	-	50 ad-pcs	
F0413-6		Yaka fitili (120 lik) T-connector Gasket for transom (F0137)	-	-	50 ad-pcs	

F50 KONDENS SİSTEM

SİLİKON CEPHE

F50 CONDENSAT SYSTEM
SILICONE FACADE

Fitil listesi
Gasket list

kod code	şekil drawing	tanım description	teorik ağırlık teoretical weight gr / m	paket ağırlığı package weight kg / package	paket metrajı in one package metre / package	kullanım yeri aplication
F0413-7		Yaka fitili (140 lik) T-connector Gasket for transom (F0138)	-	-	50 ad-pcs	
F0413-8		Yaka fitili (160 lik) T-connector Gasket for transom (F0139)	-	-	50 ad-pcs	
F0413-9		Yaka fitili (180 lik) T-connector Gasket for transom (F0140)	-	-	50 ad-pcs	
F0413-10		Yaka fitili (200lik) T-connector Gasket for transom (F0141)	-	-	50 ad-pcs	
SC0417		Kalın kama fitili Frame gasket inside	96 gr/m	15 kg	156 m	
SC0423		Taşıyıcı ve Panel iç fitili Mullion-transom or Panel gasket inside	54 gr/m	15 kg	278 m	
SC0424		Taşıyıcı ve Panel iç fitili Mullion-transom or Panel gasket inside	108 gr/m	15 kg	139 m	

F50 KONDENS SİSTEM
SİLİKON CEPHE
F50 CONDENSAT SYSTEM
SILICONE FACADE

İMALAT ŞEMASI
PRODUCTION PLAN

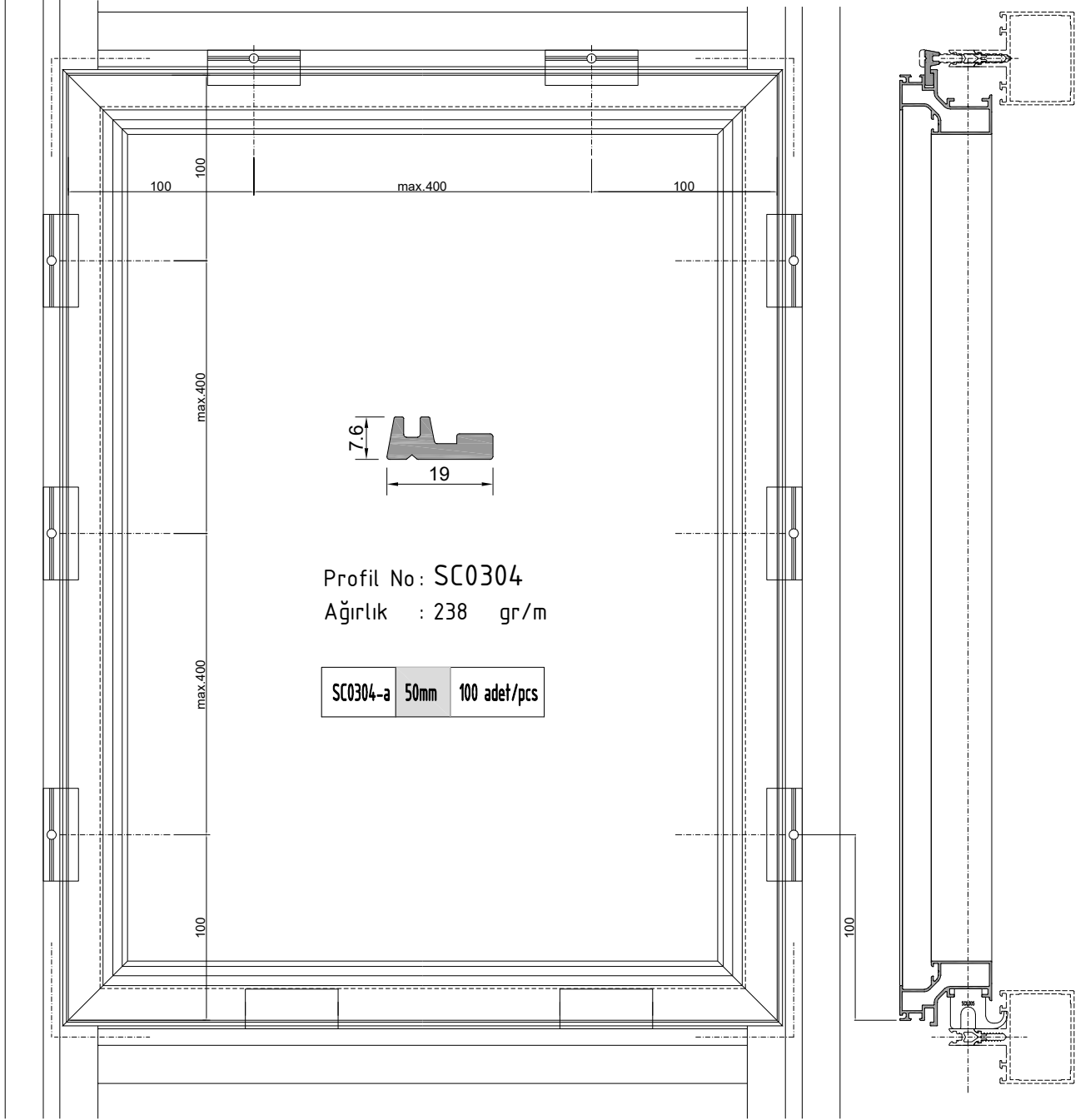

SC (T) Dıştan kilitleme sistemi
SC(T) Outside locking systems

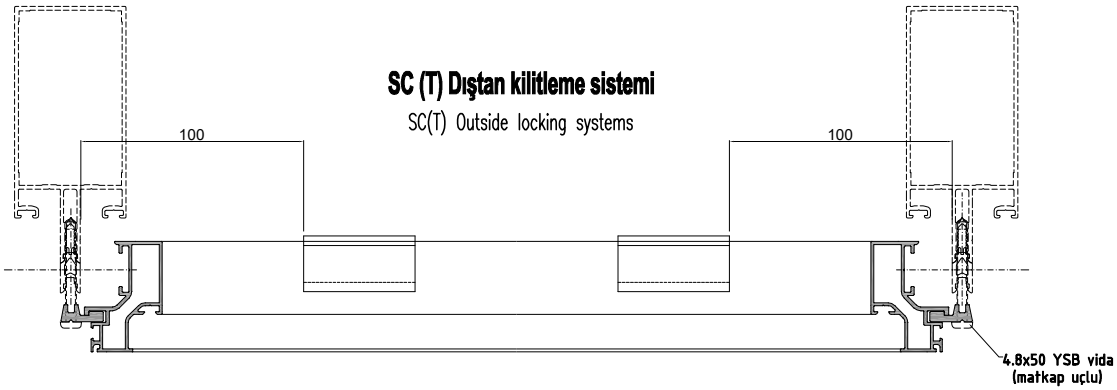

F50 KONDENS SİSTEM

SİLİKON CEPHE

F50 CONDENSAT SYSTEM
SILICONE FACADE

İMALAT ŞEMASI
PRODUCTION PLAN

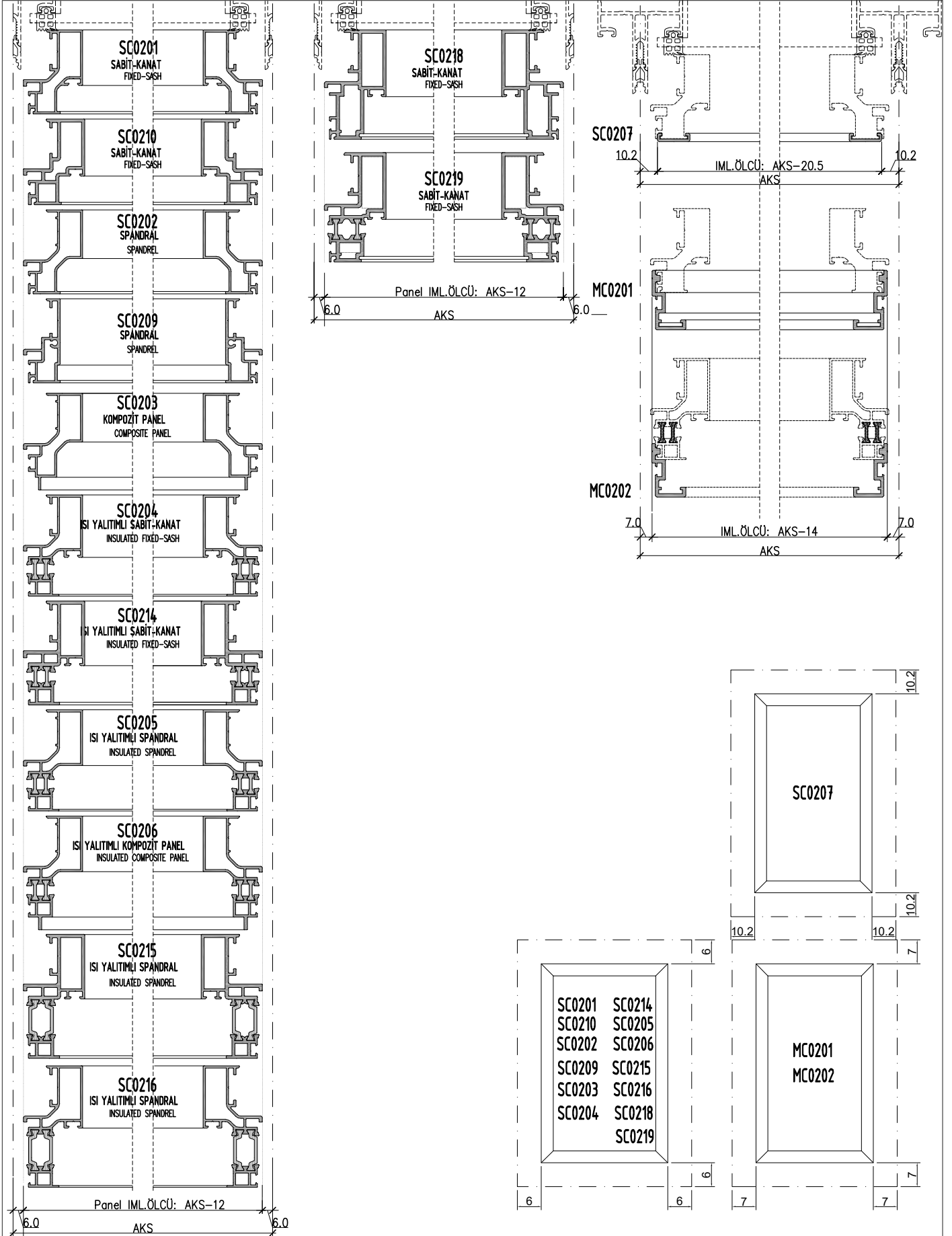

F50 KONDENS SİSTEM

SİLİKON CEPHE

F50 CONDENSAT SYSTEM
SILICONE FACADE

İMALAT ŞEMASI
PRODUCTION PLAN

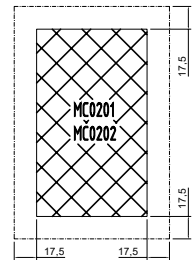
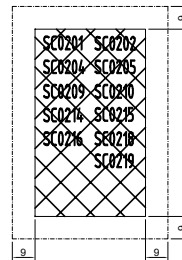
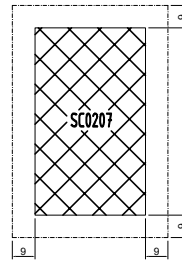
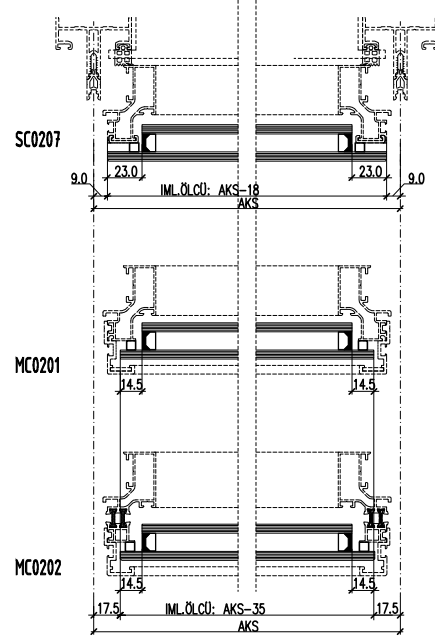
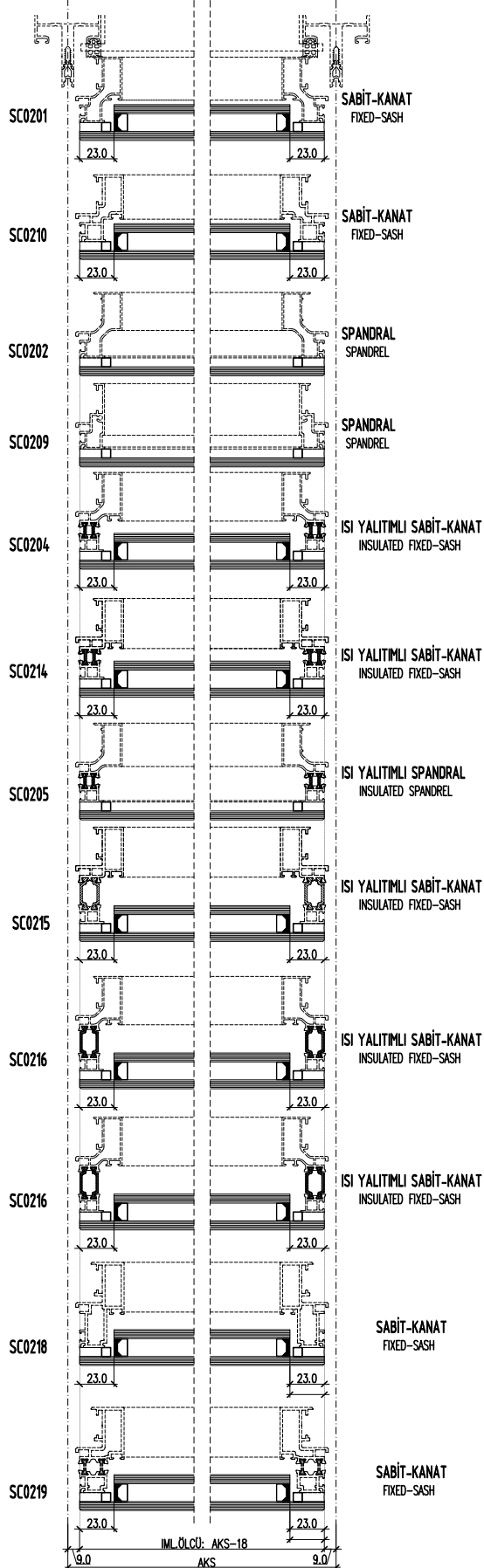

F50 KONDENS SİSTEM

SİLİKON CEPHE

F50 CONDENSAT SYSTEM
SILICONE FACADE

İMALAT ŞEMASI
PRODUCTION PLAN

CEPHE İÇİNDEN MONTAJ SİSTEMİ

ALTERNATİF -2-

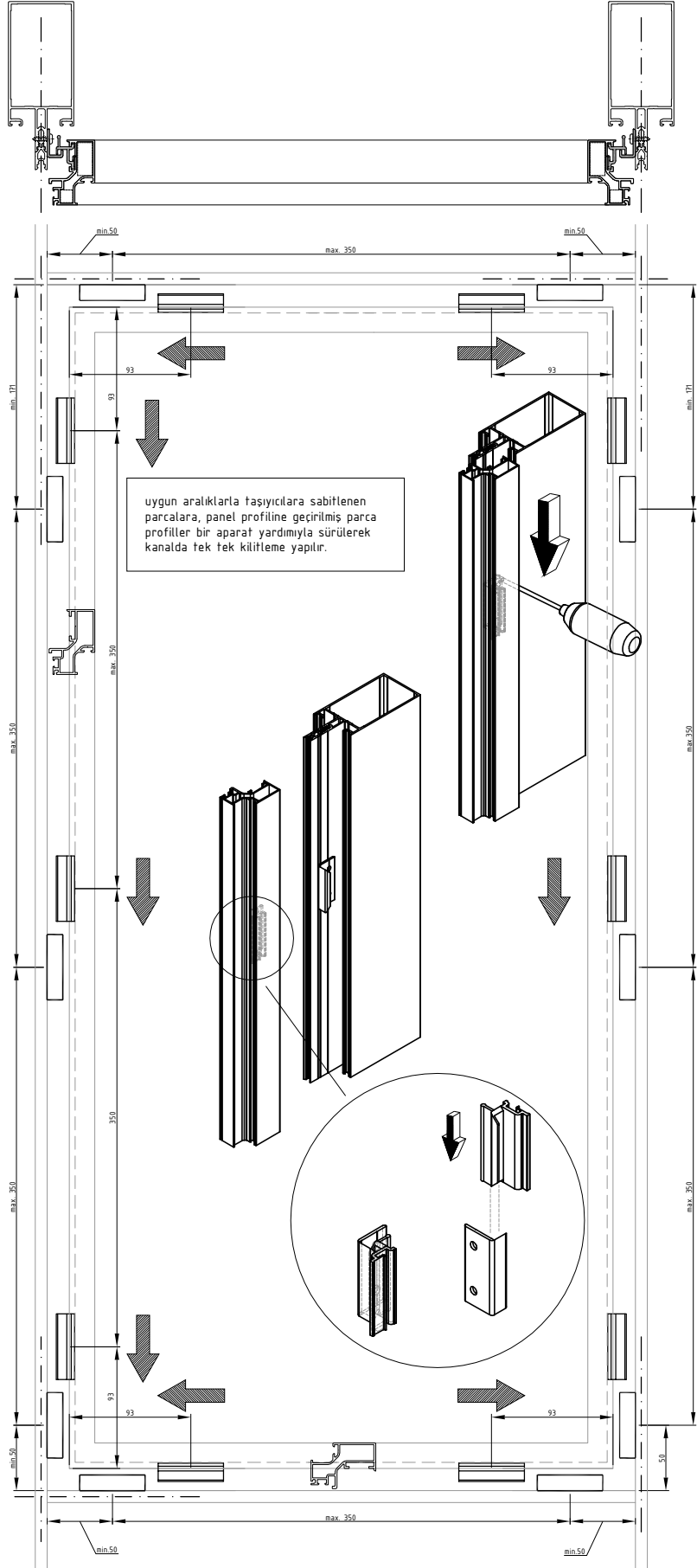
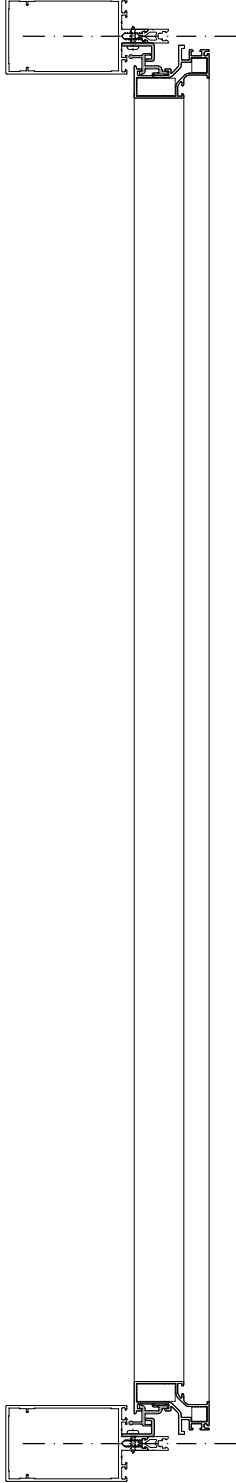

F50 KONDENS SİSTEM
SİLİKON CEPHE
F50 CONDENSAT SYSTEM
SILICONE FACADE

İMALAT ŞEMASI
PRODUCTION PLAN

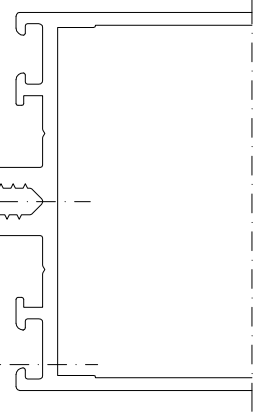
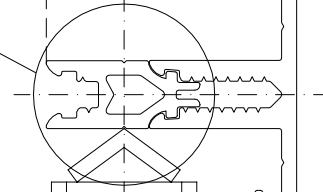
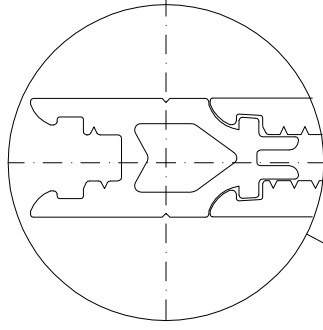
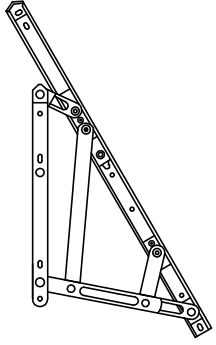

17

SC0201
SC0210
SC0209
SC0204
SC0214
SC0215
SC0216
SC0218
SC0219

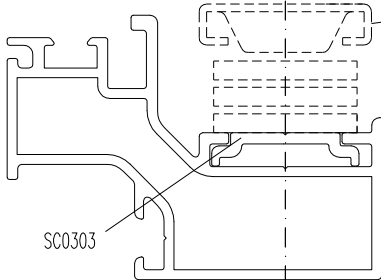

SC0303

SC0319
SC0320
SC0321
SC0322
SC0323
SC0324
SC0325
SC0326
SC0327

F50 KONDENS SİSTEM

SİLİKON CEPHE

F50 CONDENSAT SYSTEM

SILICONE FACADE

AKSESUARLAR
ACCESSOIRES

YÜKSEKLİĞE VE AĞIRLIĞA GÖRE MAXIMUM KANAT GENİSLİKLERİ
WIDTH ACCORDING TO THE WEIGHT AND THE HEIGHT

max. en boy ölçüsü

Tablodaki değerler ithal için geçerlidir.
All values are just for import

(20kg-50kg)

h/kg	20 kg	25 kg	30 kg	35 kg	40 kg	45 kg	50 kg	en
450	1500	1500	1500	1500	1500	1500	1500	weight mm
500	1500	1500	1500	1500	1500	1500	1500	weight mm
550	1500	1500	1500	1500	1500	1500	1500	weight mm
600	1500	1500	1500	1500	1500	1500	1400	weight mm
650	1500	1500	1500	1500	1500	1400	1292	en mm
700	1500	1500	1500	1400	1300	1200		en mm
750	1500	1500	1400	1307	1213	1120		en mm

SC0319 (ithal)
(import)
SC0319-a (yerli)
(native)
TYPE P - 10"
w = 23 mm
l = 261.5 mm
degree of opening 35°

(80kg-135kg)

h/kg	80 kg	90 kg	100 kg	110 kg	120 kg	130 kg	135 kg	en
700	1875	1875	1875	1875	1875	1875	1875	weight mm
800	1875	1875	1875	1875	1875	1875	1875	weight mm
900	1875	1875	1875	1875	1875	1875	1875	weight mm
1000	1875	1875	1875	1875	1875	1875	1875	weight mm
1100	1875	1875	1875	1875	1875	1875	1875	weight mm
1200	1875	1875	1875	1875	1875	1875	1875	weight mm
1300	1875	1875	1875	1875	1875	1875	1846	en mm
1400	1875	1875	1875	1875	1875	1789	1714	en mm
1500	1875	1875	1875	1875	1810	1566	1600	en mm
1600	1875	1875	1875	1829	1697	1875	1500	en mm
1700	1875	1875	1845	1721	1597	1474	1412	en mm

SC0324 (ithal)
(import)
SC0324-a (yerli)
(native)
TYPE P - 20"
w = 23 mm
l = 511.5 mm
degree of opening 25°

(30kg-60kg)

h/kg	30 kg	35 kg	40 kg	45 kg	50 kg	55 kg	60 kg	en
500	1500	1500	1500	1500	1500	1500	1500	weight mm
550	1500	1500	1500	1500	1500	1500	1500	weight mm
600	1500	1500	1500	1500	1500	1500	1500	weight mm
650	1500	1500	1500	1500	1500	1500	1477	en mm
700	1500	1500	1500	1500	1500	1472	1371	en mm
750	1500	1500	1500	1500	1467	1373	1280	en mm
800	1500	1500	1500	1463	1375	1288	1200	en mm
850	1500	1500	1459	1400	1294	1212	1129	en mm

SC0320 (ithal)
(import)
SC0320-a (yerli)
(native)
TYPE P - 12"
w = 23 mm
l = 317.5 mm
degree of opening 35°

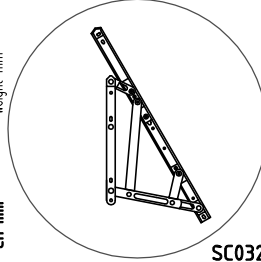

(35kg-69,5kg)

h/kg	35 kg	40 kg	45 kg	50 kg	55 kg	60 kg	65 kg	69 kg	en
550	1625	1625	1625	1625	1625	1625	1625	1625	weight mm
600	1625	1625	1625	1625	1625	1625	1625	1625	weight mm
650	1625	1625	1625	1625	1625	1625	1625	1625	weight mm
700	1625	1625	1625	1625	1625	1625	1625	1625	weight mm
750	1625	1625	1625	1625	1625	1625	1625	1625	weight mm
800	1625	1625	1625	1625	1625	1625	1625	1625	weight mm
850	1625	1625	1625	1625	1625	1604	1529	en mm	
900	1625	1625	1625	1625	1604	1514	1444	en mm	
950	1625	1625	1625	1582	1514	1435	1368	en mm	
1000	1625	1625	1625	1573	1503	1363	1300	en mm	
1050	1625	1625	1565	1498	1432	1298	1238	en mm	

SC0321 (ithal)
(import)
SC0321-a (yerli)
(native)
TYPE P - 14"
w = 23 mm
l = 353.5 mm
degree of opening 35°

(90kg-137kg)

h/kg	90 kg	100 kg	110 kg	120 kg	130 kg	137 kg	en
750	1875	1875	1875	1875	1875	1875	weight mm
900	1875	1875	1875	1875	1875	1875	weight mm
1000	1875	1875	1875	1875	1875	1875	weight mm
1100	1875	1875	1875	1875	1875	1875	weight mm
1200	1875	1875	1875	1875	1875	1875	weight mm
1300	1875	1875	1875	1875	1875	1875	weight mm
1400	1875	1875	1875	1875	1875	1821	en mm
1500	1875	1875	1875	1875	1798	1700	en mm
1600	1875	1875	1875	1875	1686	1594	en mm
1700	1875	1875	1834	1710	1587	1500	en mm
1800	1875	1875	1734	1610	1498	1417	en mm

SC0325 (ithal)
(import)
SC0325-a (yerli)
(native)
TYPE P - 22"
w = 23 mm
l = 556.5 mm
degree of opening 25°

(45kg-88,5kg)

h/kg	45 kg	50 kg	55 kg	60 kg	65 kg	70 kg	75 kg	80 kg	85 kg	88,5kg	en
600	1750	1750	1750	1750	1750	1750	1750	1750	1750	1750	weight mm
650	1750	1750	1750	1750	1750	1750	1750	1750	1750	1750	weight mm
700	1750	1750	1750	1750	1750	1750	1750	1750	1750	1750	weight mm
750	1750	1750	1750	1750	1750	1750	1750	1750	1750	1750	weight mm
800	1750	1750	1750	1750	1750	1750	1750	1750	1750	1750	weight mm
850	1750	1750	1750	1750	1750	1750	1750	1750	1750	1750	weight mm
900	1750	1750	1750	1750	1750	1750	1750	1750	1750	1750	weight mm
950	1750	1750	1750	1750	1750	1750	1750	1750	1750	1750	weight mm
1000	1750	1750	1750	1750	1750	1750	1750	1750	1739	1680	en mm
1050	1750	1750	1750	1750	1750	1750	1750	1738	1657	1600	en mm
1100	1750	1750	1750	1750	1750	1736	1659	1581	1527		en mm
1150	1750	1750	1750	1750	1734	1660	1586	1513	1461		en mm
1200	1750	1750	1750	1733	1662	1591	1520	1450	1400		en mm
1250	1750	1750	1731	1663	1595	1528	1460	1392	1344		en mm
1300	1750	1730	1665	1560	1534	1470	1403	1338	1292		en mm

SC0322 (ithal)
(import)
SC0322-a (yerli)
(native)
TYPE P - 16"
w = 23 mm
l = 414.5 mm
degree of opening 30°

(90kg-137kg)

h/kg	90 kg	100 kg	110 kg	120 kg	130 kg	139 kg	en
800	1875	1875	1875	1875	1875	1875	weight mm
950	1875	1875	1875	1875	1875	1875	weight mm
1100	1875	1875	1875	1875	1875	1875	weight mm
1200	1875	1875	1875	1875	1875	1875	weight mm
1300	1875	1875	1875	1875	1875	1875	weight mm
1400	1875	1875	1875	1875	1875	1875	weight mm
1500	1875	1875	1875	1875	1875	1800	en mm
1600	1875	1875	1875	1875	1806	1688	en mm
1700	1875	1875	1875	1823	1700	1588	en mm
1800	1875	1875	1839	1722	1605	1500	en mm
1900	1875	1875	1742	1631	1521	1421	en mm

SC0326 (ithal)
(import)
SC0326-a (yerli)
(native)
TYPE P - 24"
w = 23 mm
l = 602.5 mm
degree of opening 25°

(55kg-102kg)

h/kg	55 kg	60 kg	65 kg	70 kg	75 kg	80 kg	85 kg	90 kg	95 kg	102 kg	en
650	1750	1750	1750	1750	1750	1750	1750	1750	1750	1750	weight mm
750	1750	1750	1750	1750	1750	1750	1750	1750	1750	1750	weight mm
850	1750	1750	1750	1750	1750	1750	1750	1750	1750	1750	weight mm
950	1750	1750	1750	1750	1750	1750	1750	1750	1750	1750	weight mm
850	1750	1750	1750	1750	1750	1750	1750	1750	1750	1750	weight mm
1050	1750	1750	1750	1750	1750	1750	1750	1750	1750	1704	en mm
1150	1750	1750	1750	1750	1750	1750	1731	1663	1568		en mm
1250	1750	1750	1750	1750	1729	1666	1603	1540	1452		en mm
1350	1750	1750	1750	1728	1667	1606	1546	1485	1400		en mm
1450	1750	1750	1750	1727	1668	1610	1551	1492	1434	1352	en mm
1500	1750	1750	1750	1669	1613	1556	1499	1443	1386	1307	en mm

SC0323 (ithal)
(import)
SC0323-a (yerli)
(native)
TYPE P - 18"
w = 23 mm
l = 458.5 mm
degree of opening 30°

(90kg-137kg)

h/kg	105 kg	115 kg	125 kg	135 kg	145 kg	155 kg	en
900	1875	1875	1875	1875	1875	1875	weight mm
1100	1875	1875	1875	1875	1875	1875	weight mm
1300	1875	1875	1875	1875	1875	1875	weight mm
1500	1875	1875	1875	1875	1875	1875	weight mm
1600	1875	1875	1875	1875	1875	1875	weight mm
1700	1875	1875	1875	1875	1875	1765	en mm
1800	1875	1875	1875	1875	1816	1667	en mm
1900	1875	1875	1875	1863	1721	1579	en mm
2000	1875	1875	1875	1770	1635	1500	en mm
2100	1875	1875	1814	1685	1557	1429	en mm

F50 KONDENS SİSTEM

SİLİKON CEPHE

F50 CONDENSAT SYSTEM
SILICONE FACADE

AKSESUARLAR
ACCESSOIRES

DALDIRMA GALVENİZLİ SABİT U ANKRAJ (DÜŞEY BAKLALI) DIP GALVANIZED FIX "U" ANCHOR (VERTICAL)

- SC0338-1 (yerli) (native) L= 80 mm
- SC0339-1 (yerli) (native) L= 100 mm
- SC0340-1 (yerli) (native) L= 120 mm
- SC0341-1 (yerli) (native) L= 150 mm
- SC0342-1 (yerli) (native) L= 200 mm

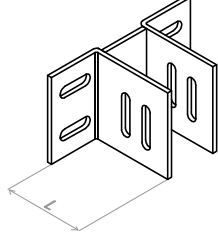

DALDIRMA GALVENİZLİ SABİT U ANKRAJ (YATAY BAKLALI) DIP GALVANIZED FIX "U" ANCHOR (HORIZONTAL)

- SC0338-2 (yerli) (native) L= 80 mm
- SC0339-2 (yerli) (native) L= 100 mm
- SC0340-2 (yerli) (native) L= 120 mm
- SC0341-2 (yerli) (native) L= 150 mm
- SC0342-2 (yerli) (native) L= 200 mm

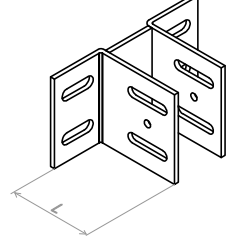

TAŞIYICI DİLATASYON PLASTİĞİ DILATION PLASTIC FOR MULLION

F0801 (yerli) (native)

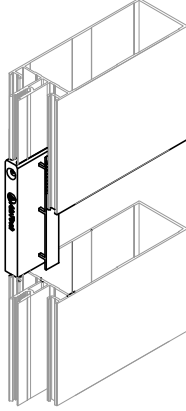
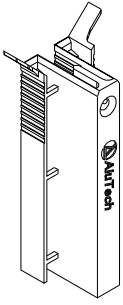

DÜŞEY TAŞIYICI SU TAHLİYE PLASTİĞİ CONDENSAT PLASTIC FOR MULLION

F0802 (yerli) (native)

